

dáváme plánům život

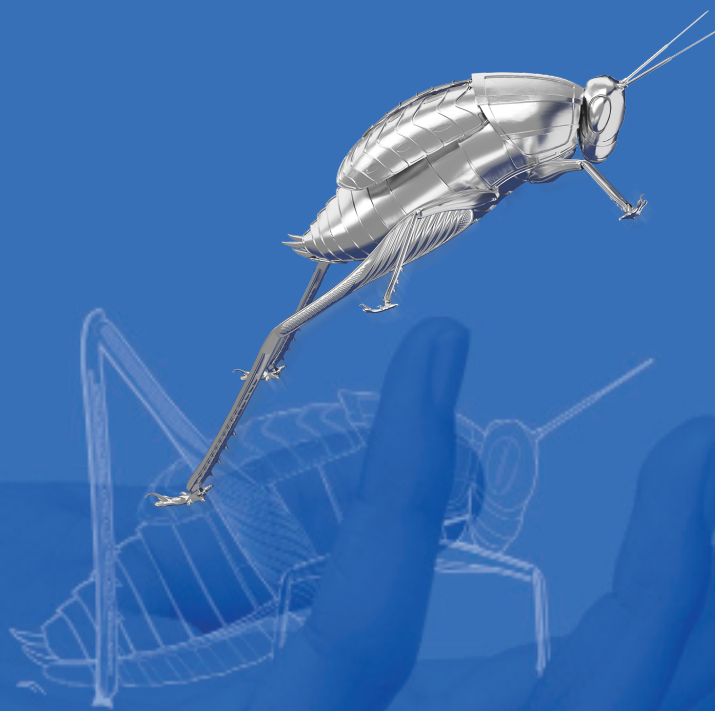

Zaujati strojírenstvím,

pohánění myšlenkami.

Upínací kužely

DIN 69871

Upínací kužely jsou předvyváženy.

G 6.3 15.000 min⁻¹ , G 2,5 25.000 min⁻¹
(G 2.5 vyšší vyvážení za příplatek)

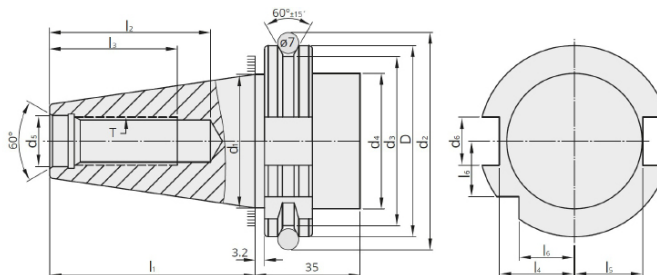

Kužel	D 0 -0,1	d ₁	d ₂ ± 0,05	d ₃ 0 -0,5	d ₄ max	d ₅ H7	d ₆ H12	d ₉	l ₁ 0 -0,3	l ₂ min	l ₃ min	l ₄ 0 -0,4	l ₅ 0 -0,4	l ₆ 0 -0,3	e ₁ ± 0,1	e ₂ max	T max
ISO30	50	31,75	59,30	44,30	45	13	16,1	4	47,8	33,5	24	19	16,4	15	21	5	M12
ISO40	63,55	44,45	72,30	56,25	50	17	16,1	4	68,4	42,5	32	25	22,8	18,5	27	5	M16
ISO50	97,50	69,85	107,25	91,25	80	25	25,7	6	101,75	61,5	47	37,7	35,5	30	42	7	M24

S vnitřním chlazením přes límec – typ AD/B

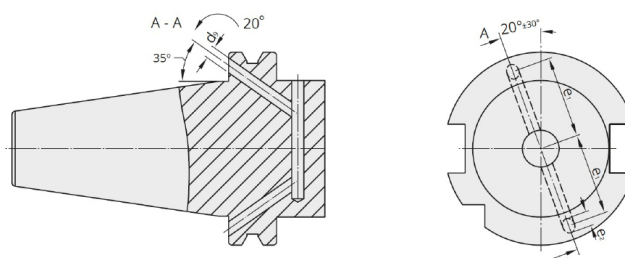

Dodávka se šrouby bez hlavy v zavřené pozici.

materiál: legovaná ocel cementovaná do hl. 0.8 ± 0.2 mm, kalená na 60 ± 2 HRC
s pevností v jádru min. 950 N/mm²
černěno a přesně broušeno

provedení AD/B: dodáváno v typu AD, typ B se šrouby bez hlavy v zavřené pozici

přesnost: kvalita kuželu < AT3 dle normy DIN 7187 a DIN 2080

NA-U-SK-1-001-03/23



NA-U-SK-1-002-03/23



NA-U-SK-1-002-03/23



NA-U-SK-1-003-03/23



NA-U-SK-2-001-03/23



NA-U-SK-2-002-03/23



NA-U-SK-3-001-03/23



NA-U-SK-4-001-03/23



NA-U-SK-4-001-03/23



NA-U-SK-5-001-03/23



NA-U-SK-5-002-03/23



NA-U-SK-6-001-03/23



NA-U-SK-6-001-03/23



NA-U-SK-6-002-03/23



NA-U-SK-6-002-03/23



NA-U-SK-6-003-03/23



NA-U-SK-7-001-03/23



NA-U-SK-8-001-03/23



NA-U-SK-8-002-03/23



NA-U-SK-8-003-03/23



NA-U-SK-9-001-03/23



NA-U-SK-9-001-03/23



NA-U-SK-9-001-03/23



NA-U-SK-9-002-03/23



Kleštinový upínač pro kleštiny ER



DIN 6499 (ISO 15488)

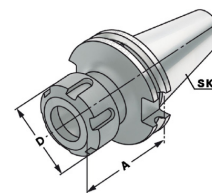

Název	Kužel	Rozsah	D	A			G 2,5 25.000 min ⁻¹
SK40.63.ER.16.AD	SK40	1 – 10 (ER 16)	32	63	AD	ER16K	•
SK40.70.ER.20.AD	SK40	2 – 13 (ER 20)	35	70	AD	ER20K	•
SK40.60.ER.25.AD	SK40	2 – 16 (ER 25)	42	60	AD	ER25K	•
SK40.70.ER.32.AD	SK40	2 – 20 (ER 32)	50	70	AD	ER32K	•
SK40.80.ER.40.AD	SK40	3 – 26 (ER 40)	63	80	AD	ER40K	•
SK40.100.ER.16.AD	SK40	1 – 10 (ER 16)	32	100	AD	ER16K	•
SK40.100.ER.20.AD	SK40	2 – 13 (ER 20)	35	100	AD	ER20K	•
SK40.100.ER.25.AD	SK40	2 – 16 (ER 25)	42	100	AD	ER25K	•
SK40.100.ER.32.AD	SK40	2 – 20 (ER 32)	50	100	AD	ER32K	•
SK40.100.ER.40.AD	SK40	3 – 26 (ER 40)	63	100	AD	ER40K	•
SK40.63.ER.16.ADB	SK40	1 – 10 (ER 16)	32	63	AD/B	ER16K	•
SK40.70.ER.20.ADB	SK40	2 – 13 (ER 20)	35	70	AD/B	ER20K	•
SK40.60.ER.25.ADB	SK40	2 – 16 (ER 25)	42	60	AD/B	ER25K	•
SK40.70.ER.32.ADB	SK40	2 – 20 (ER 32)	50	70	AD/B	ER32K	•
SK40.80.ER.40.ADB	SK40	3 – 26 (ER 40)	63	80	AD/B	ER40K	•
SK40.100.ER.16.ADB	SK40	1 – 10 (ER 16)	32	100	AD/B	ER16K	•
SK40.100.ER.20.ADB	SK40	2 – 13 (ER 20)	35	100	AD/B	ER20K	•
SK40.100.ER.25.ADB	SK40	2 – 16 (ER 25)	42	100	AD/B	ER25K	•
SK40.100.ER.32.ADB	SK40	2 – 20 (ER 32)	50	100	AD/B	ER32K	•
SK40.100.ER.40.ADB	SK40	3 – 26 (ER 40)	63	100	AD/B	ER40K	•
SK.40.130.ER.16.ADB	SK40	1 – 10 (ER 16)	32	130	AD/B	ER16K	•
SK.40.130.ER.20.ADB	SK40	2 – 13 (ER 20)	35	130	AD/B	ER20K	•
SK.40.130.ER.25.ADB	SK40	2 – 16 (ER 25)	42	130	AD/B	ER25K	•
SK.40.130.ER.32.ADB	SK40	2 – 20 (ER 32)	50	130	AD/B	ER32K	•
SK.40.130.ER.40.ADB	SK40	3 – 26 (ER 40)	63	130	AD/B	ER40K	•
SK40.160.ER.16.ADB	SK40	1 – 10 (ER 16)	32	160	AD/B	ER16K	•
SK40.160.ER.20.ADB	SK40	2 – 13 (ER 20)	35	160	AD/B	ER20K	•
SK40.160.ER.25.ADB	SK40	2 – 16 (ER 25)	42	160	AD/B	ER25K	•
SK40.160.ER.32.ADB	SK40	2 – 20 (ER 32)	50	160	AD/B	ER32K	•
SK40.160.ER.40.ADB	SK40	3 – 26 (ER 40)	63	160	AD/B	ER40K	•
SK40.200.ER.16.ADB	SK40	1 – 10 (ER 16)	32	200	AD/B	ER16K	•
SK40.200.ER.20.ADB	SK40	2 – 13 (ER 20)	35	200	AD/B	ER20K	•
SK40.200.ER.25.ADB	SK40	2 – 16 (ER 25)	42	200	AD/B	ER25K	•
SK40.200.ER.32.ADB	SK40	2 – 20 (ER 32)	50	200	AD/B	ER32K	•
SK40.200.ER.40.ADB	SK40	3 – 26 (ER 40)	63	200	AD/B	ER40K	•

dodávka: s vyváženou upínací maticí, bez montážního klíče





Kleštinový upínač pro kleštiny ER

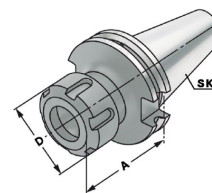

DIN 6499 (ISO 15488)



Název	Kužel	Rozsah	D	A			G 2,5 25.000 min ⁻¹
SK50.70.ER.16.ADB	SK50	1 – 10 (ER 16)	32	70	AD/B	ER16K	•
SK50.70.ER.20.ADB	SK50	2 – 13 (ER 20)	35	70	AD/B	ER20K	•
SK50.60.ER.25.ADB	SK50	2 – 16 (ER 25)	42	60	AD/B	ER25K	•
SK50.70.ER.32.ADB	SK50	2 – 20 (ER 32)	50	70	AD/B	ER32K	•
SK50.80.ER.40.ADB	SK50	3 – 26 (ER 40)	63	80	AD/B	ER40K	•
SK50.100.ER.16.ADB	SK50	1 – 10 (ER 16)	32	100	AD/B	ER16K	•
SK50.100.ER.20.ADB	SK50	2 – 13 (ER 20)	35	100	AD/B	ER20K	•
SK50.100.ER.25.ADB	SK50	2 – 16 (ER 25)	42	100	AD/B	ER25K	•
SK50.100.ER.32.ADB	SK50	2 – 20 (ER 32)	50	100	AD/B	ER32K	•
SK50.100.ER.40.ADB	SK50	3 – 26 (ER 40)	63	100	AD/B	ER40K	•
SK50.130.ER.16.ADB	SK50	1 – 10 (ER 16)	32	130	AD/B	ER16K	•
SK50.130.ER.20.ADB	SK50	2 – 13 (ER 20)	35	130	AD/B	ER20K	•
SK50.130.ER.25.ADB	SK50	2 – 16 (ER 25)	42	130	AD/B	ER25K	•
SK50.130.ER.32.ADB	SK50	2 – 20 (ER 32)	50	130	AD/B	ER32K	•
SK50.130.ER.40.ADB	SK50	3 – 26 (ER 40)	63	130	AD/B	ER40K	•
SK50.160.ER.16.ADB	SK50	1 – 10 (ER 16)	32	160	AD/B	ER16K	•
SK50.160.ER.20.ADB	SK50	2 – 13 (ER 20)	35	160	AD/B	ER20K	•
SK50.160.ER.25.ADB	SK50	2 – 16 (ER 25)	42	160	AD/B	ER25K	•
SK50.160.ER.32.ADB	SK50	2 – 20 (ER 32)	50	160	AD/B	ER32K	•
SK50.160.ER.40.ADB	SK50	3 – 26 (ER 40)	63	160	AD/B	ER40K	•
SK50.200.ER.16.ADB	SK50	1 – 10 (ER 16)	32	200	AD/B	ER16K	•
SK50.200.ER.20.ADB	SK50	2 – 13 (ER 20)	35	200	AD/B	ER20K	•
SK50.200.ER.25.ADB	SK50	2 – 16 (ER 25)	42	200	AD/B	ER25K	•
SK50.200.ER.32.ADB	SK50	2 – 20 (ER 32)	50	200	AD/B	ER32K	•
SK50.200.ER.40.ADB	SK50	3 – 26 (ER 40)	63	200	AD/B	ER40K	•

dodávka: s vyváženou upínací maticí, bez montážního klíče



Kleštinový upínač úzký pro kleštiny ER



DIN 6499 (ISO 15488)

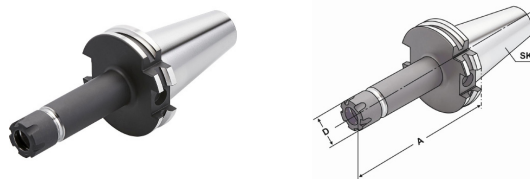

Název	Kužel	Rozsah	D	A			G 2,5 25.000 min ⁻¹
SK40.55.ERM.11.ADB	SK40	1 – 7 (ER 11)	16	55	AD/B	ER11MK	•
SK40.100.ERM.11.ADB	SK40	1 – 7 (ER 11)	16	100	AD/B	ER11MK	•
SK40.160.ERM.11.ADB	SK40	1 – 7 (ER 11)	16	160	AD/B	ER11MK	•
SK40.55.ERM.16.ADB	SK40	1 – 10 (ER 16)	22	55	AD/B	ER16MK	•
SK40.100.ERM.16.ADB	SK40	1 – 10 (ER 16)	22	100	AD/B	ER16MK	•
SK40.160.ERM.16.ADB	SK40	1 – 10 (ER 16)	22	160	AD/B	ER16MK	•
SK50.100.ERM.16.ADB	SK50	1 – 10 (ER 16)	22	100	AD/B	ER16MK	•
SK50.160.ERM.16.ADB	SK50	1 – 10 (ER 16)	22	160	AD/B	ER16MK	•
SK40.70.ERM.20.ADB	SK40	2 – 13 (ER20)	28	70	AD/B	ER20MK	•
SK40.100.ERM.20.ADB	SK40	2 – 13 (ER20)	28	100	AD/B	ER20MK	•
SK40.160.ERM.20.ADB	SK40	2 – 13 (ER20)	28	160	AD/B	ER20MK	•
SK40.70.ERM.25.ADB	SK40	2 – 16 (ER25)	35	70	AD/B	ER25MK	•
SK40.100.ERM.25.ADB	SK40	2 – 16 (ER25)	35	100	AD/B	ER25MK	•
SK40.160.ERM.25.ADB	SK40	2 – 16 (ER25)	35	160	AD/B	ER25MK	•

dodávka: s vyváženou upínací maticí bez montážního klíče

Silový kleštinový upínač

Pro upínací stopky DIN 1835 A+B+E a DIN 6535 HA+HB+HE

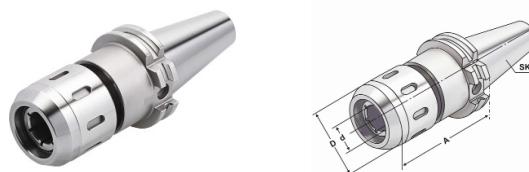

Název	Kužel	Rozsah	D	d	A			G 6,3 15.000 min ⁻¹
SK40.90.S.20.ADB	SK40	3 – 20 (RS20)	53	20	90	AD/B	RS20K	•
SK40.105.S.25.ADB	SK40	3 – 25 (RS25)	63	25	105	AD/B	RS25K	•
SK40.105.S.32.ADB	SK40	3 – 32 (RS32)	68	32	105	AD/B	RS32K	•
SK50.90.S.20.ADB	SK50	3 – 20 (RS20)	53	20	90	AD/B	RS20K	•
SK50.90.S.25.ADB	SK50	3 – 25 (RS25)	63	25	90	AD/B	RS25K	•
SK50.90.S.32.ADB	SK50	3 – 32 (RS32)	68	32	90	AD/B	RS32K	•

dodávka: bez montážního klíče

Velikost	20 mm	25 mm	32 mm
Upínací moment	50 – 70 Nm	80 – 100 Nm	80 – 100 Nm
Upínací síla	780 Nm	2000 Nm	2000 Nm





Kleštinový upínač pro kleštiny ER BEZ UNAŠECÍCH DRÁŽEK

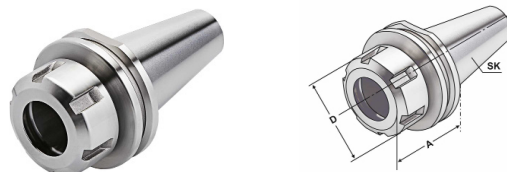

DIN 6499 (ISO 15488)



Název	Kužel	Rozsah	D	A			G 2,5 25.000 min ⁻¹
SK30B.50.ER.25.AD	SK30	2 – 16 (ER 25)	42	50	AD	ER25K	•
SK30B.50.ER.32.AD	SK30	2 – 20 (ER 32)	50	50	AD	ER32K	•
SK30B.57.ER.32.AD	SK30	2 – 20 (ER 32)	50	57	AD	ER32K	•
SK30B.63.ER.32.AD	SK30	2 – 20 (ER 32)	50	63	AD	ER32K	•
SK30B.60.ER.40.AD	SK30	3 – 26 (ER 40)	63	60	AD	ER40K	•
SK40B.50.ER.25.AD	SK40	2 – 16 (ER 25)	42	50	AD	ER25K	•
SK40B.50.ER.32.AD	SK40	2 – 20 (ER 32)	50	50	AD	ER32K	•
SK40B.63.ER.40.AD	SK40	3 – 26 (ER 40)	63	63	AD	ER40K	•

dodávka: s vyváženou upínací maticí, bez montážního klíče



Upínač Weldon pro upínací stopky



Upínač Weldon DIN 6359 pro upínací stopky DIN 1835-B

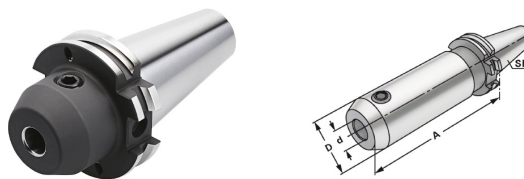

Název	Kužel	D	d	A		G 2,5 25.000 min ⁻¹
SK40.50.WE.06.AD	SK40	25	6	50	AD	•
SK40.50.WE.08.AD	SK40	28	8	50	AD	•
SK40.50.WE.10.AD	SK40	35	10	50	AD	•
SK40.50.WE.12.AD	SK40	42	12	50	AD	•
SK40.50.WE.14.AD	SK40	44	14	50	AD	•
SK40.63.WE.16.AD	SK40	48	16	63	AD	•
SK40.63.WE.18.AD	SK40	50	18	63	AD	•
SK40.63.WE.20.AD	SK40	52	20	63	AD	•
SK40.100.WE.25.AD	SK40	65	25	100	AD	•
SK40.100.WE.32.AD	SK40	72	32	100	AD	•
SK40.100.WE.06.AD	SK40	25	6	100	AD	•
SK40.100.WE.08.AD	SK40	28	8	100	AD	•
SK40.100.WE.10.AD	SK40	35	10	100	AD	•
SK40.100.WE.12.AD	SK40	42	12	100	AD	•
SK40.100.WE.14.AD	SK40	44	14	100	AD	•
SK40.100.WE.16.AD	SK40	48	16	100	AD	•
SK40.100.WE.18.AD	SK40	50	18	100	AD	•
SK40.100.WE.20.AD	SK40	52	20	100	AD	•

od průměr d = 25 se dvěma upínacími šrouby



Upínač Weldon pro upínací stopky



Upínač Weldon DIN 6359 pro upínací stopky DIN 1835-B

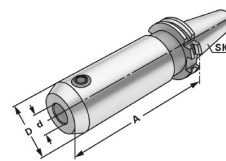

Název	Kužel	D	d	A		G 2,5 25.000 min ⁻¹
SK40.35.WE.16.ADB	SK40	45	16	35	AD/B	•
SK40.35.WE.20.ADB	SK40	45	20	35	AD/B	•
SK40.35.WE.25.ADB	SK40	45	25	35	AD/B	•
SK40.65.WE.32.ADB	SK40	50	32	65	AD/B	•
SK40.50.WE.06.ADB	SK40	25	6	50	AD/B	•
SK40.50.WE.08.ADB	SK40	28	8	50	AD/B	•
SK40.50.WE.10.ADB	SK40	35	10	50	AD/B	•
SK40.50.WE.12.ADB	SK40	42	12	50	AD/B	•
SK40.50.WE.14.ADB	SK40	44	14	50	AD/B	•
SK40.63.WE.16.ADB	SK40	48	16	63	AD/B	•
SK40.63.WE.18.ADB	SK40	50	18	63	AD/B	•
SK40.63.WE.20.ADB	SK40	52	20	63	AD/B	•
SK40.100.WE.25.ADB	SK40	65	25	100	AD/B	•
SK40.100.WE.32.ADB	SK40	72	32	100	AD/B	•
SK40.120.WE.40.ADB	SK40	80	40	120	AD/B	•
SK40.100.WE.06.ADB	SK40	25	6	100	AD/B	•
SK40.100.WE.08.ADB	SK40	28	8	100	AD/B	•
SK40.100.WE.10.ADB	SK40	35	10	100	AD/B	•
SK40.100.WE.12.ADB	SK40	42	12	100	AD/B	•
SK40.100.WE.14.ADB	SK40	44	14	100	AD/B	•
SK40.100.WE.16.ADB	SK40	48	16	100	AD/B	•
SK40.100.WE.18.ADB	SK40	50	18	100	AD/B	•
SK40.100.WE.20.ADB	SK40	52	20	100	AD/B	•
SK40.130.WE.06.ADB	SK40	25	6	130	AD/B	•
SK40.130.WE.08.ADB	SK40	28	8	130	AD/B	•
SK40.130.WE.10.ADB	SK40	35	10	130	AD/B	•
SK40.130.WE.12.ADB	SK40	42	12	130	AD/B	•
SK40.130.WE.14.ADB	SK40	44	14	130	AD/B	•
SK40.130.WE.16.ADB	SK40	48	16	130	AD/B	•
SK40.130.WE.18.ADB	SK40	50	18	130	AD/B	•
SK40.130.WE.20.ADB	SK40	52	20	130	AD/B	•
SK40.160.WE.06.ADB	SK40	25	6	160	AD/B	•
SK40.160.WE.08.ADB	SK40	28	8	160	AD/B	•
SK40.160.WE.10.ADB	SK40	35	10	160	AD/B	•
SK40.160.WE.12.ADB	SK40	42	12	160	AD/B	•
SK40.160.WE.14.ADB	SK40	44	14	160	AD/B	•
SK40.160.WE.16.ADB	SK40	48	16	160	AD/B	•
SK40.160.WE.18.ADB	SK40	50	18	160	AD/B	•
SK40.160.WE.20.ADB	SK40	52	20	160	AD/B	•
SK40.160.WE.25.ADB	SK40	65	25	160	AD/B	•
SK40.160.WE.32.ADB	SK40	72	32	160	AD/B	•
SK40.160.WE.40.ADB	SK40	80	40	160	AD/B	•

od průměr d = 25 se dvěma upínacími šrouby



Upínač Weldon pro upínací stopky



Upínač Weldon DIN 6359 pro upínací stopky DIN 1835-B

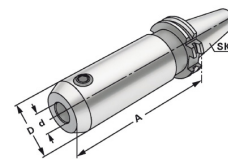

Název	Kužel	D	d	A		G 2,5 25.000 min ⁻¹
SK50.63.WE.06.ADB	SK50	25	6	63	AD/B	•
SK50.63.WE.08.ADB	SK50	28	8	63	AD/B	•
SK50.63.WE.10.ADB	SK50	35	10	63	AD/B	•
SK50.63.WE.12.ADB	SK50	42	12	63	AD/B	•
SK50.63.WE.14.ADB	SK50	44	14	63	AD/B	•
SK50.63.WE.16.ADB	SK50	48	16	63	AD/B	•
SK50.63.WE.18.ADB	SK50	50	18	63	AD/B	•
SK50.63.WE.20.ADB	SK50	52	20	63	AD/B	•
SK50.80.WE.25.ADB	SK50	65	25	80	AD/B	•
SK50.100.WE.32.ADB	SK50	72	32	100	AD/B	•
SK50.100.WE.40.ADB	SK50	80	40	100	AD/B	•
SK50.120.WE.50.ADB	SK50	99	50	120	AD/B	•
SK50.100.WE.06.ADB	SK50	25	6	100	AD/B	•
SK50.100.WE.08.ADB	SK50	28	8	100	AD/B	•
SK50.100.WE.10.ADB	SK50	35	10	100	AD/B	•
SK50.100.WE.12.ADB	SK50	42	12	100	AD/B	•
SK50.100.WE.14.ADB	SK50	44	14	100	AD/B	•
SK50.100.WE.16.ADB	SK50	48	16	100	AD/B	•
SK50.100.WE.18.ADB	SK50	50	18	100	AD/B	•
SK50.100.WE.20.ADB	SK50	52	20	100	AD/B	•
SK50.120.WE.25.ADB	SK50	65	25	120	AD/B	•
SK50.130.WE.06.ADB	SK50	25	6	130	AD/B	•
SK50.130.WE.08.ADB	SK50	28	8	130	AD/B	•
SK50.130.WE.10.ADB	SK50	35	10	130	AD/B	•
SK50.130.WE.12.ADB	SK50	42	12	130	AD/B	•
SK50.130.WE.14.ADB	SK50	44	14	130	AD/B	•
SK50.130.WE.16.ADB	SK50	48	16	130	AD/B	•
SK50.130.WE.18.ADB	SK50	50	18	130	AD/B	•
SK50.130.WE.20.ADB	SK50	52	20	130	AD/B	•

od průměr d = 25 se dvěma upínacími šrouby



Upínač Weldon pro upínací stopky



Upínač Weldon DIN 6359 pro upínací stopky DIN 1835-B

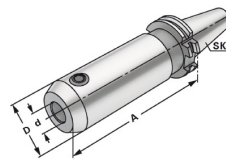

Název	Kužel	D	d	A		G 2,5 25.000 min ⁻¹
SK50.160.WE.06.ADB	SK50	25	6	160	AD/B	•
SK50.160.WE.08.ADB	SK50	28	8	160	AD/B	•
SK50.160.WE.10.ADB	SK50	35	10	160	AD/B	•
SK50.160.WE.12.ADB	SK50	42	12	160	AD/B	•
SK50.160.WE.14.ADB	SK50	44	14	160	AD/B	•
SK50.160.WE.16.ADB	SK50	48	16	160	AD/B	•
SK50.160.WE.18.ADB	SK50	50	18	160	AD/B	•
SK50.160.WE.20.ADB	SK50	52	20	160	AD/B	•
SK50.160.WE.25.ADB	SK50	65	25	160	AD/B	•
SK50.160.WE.32.ADB	SK50	72	32	160	AD/B	•
SK50.160.WE.40.ADB	SK50	80	40	160	AD/B	•
SK50.200.WE.06.ADB	SK50	25	6	200	AD/B	•
SK50.200.WE.08.ADB	SK50	28	8	200	AD/B	•
SK50.200.WE.10.ADB	SK50	35	10	200	AD/B	•
SK50.200.WE.12.ADB	SK50	42	12	200	AD/B	•
SK50.200.WE.14.ADB	SK50	44	14	200	AD/B	•
SK50.200.WE.16.ADB	SK50	48	16	200	AD/B	•
SK50.200.WE.18.ADB	SK50	50	18	200	AD/B	•
SK50.200.WE.20.ADB	SK50	52	20	200	AD/B	•
SK50.200.WE.25.ADB	SK50	65	25	200	AD/B	•
SK50.200.WE.32.ADB	SK50	72	32	200	AD/B	•
SK50.200.WE.40.ADB	SK50	80	40	200	AD/B	•

od průměr d = 25 se dvěma upínacími šrouby



Upínač Weldon s chladicími kanály pro upínací stopky



Upínač Weldon DIN 6359 pro upínací stopky DIN 1835-B

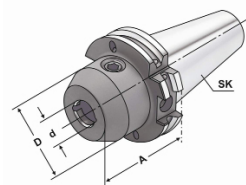

Název	Kužel	d	D	A		G 2,5 25.000 min ⁻¹
SK40.50.WK.06.ADB	SK40	6	25	50	AD/B	•
SK40.50.WK.08.ADB	SK40	8	28	50	AD/B	•
SK40.50.WK.10.ADB	SK40	10	35	50	AD/B	•
SK40.50.WK.12.ADB	SK40	12	42	50	AD/B	•
SK40.50.WK.14.ADB	SK40	14	44	50	AD/B	•
SK40.63.WK.16.ADB	SK40	16	48	63	AD/B	•
SK40.63.WK.18.ADB	SK40	18	50	63	AD/B	•
SK40.63.WK.20.ADB	SK40	20	52	63	AD/B	•
SK40.100.WK.25.ADB	SK40	25	65	100	AD/B	•
SK40.100.WK.32.ADB	SK40	32	72	100	AD/B	•
SK40.120.WK.40.ADB	SK40	40	80	120	AD/B	•
SK40.100.WK.06.ADB	SK40	6	25	100	AD/B	•
SK40.100.WK.08.ADB	SK40	8	28	100	AD/B	•
SK40.100.WK.10.ADB	SK40	10	35	100	AD/B	•
SK40.100.WK.12.ADB	SK40	12	42	100	AD/B	•
SK40.100.WK.14.ADB	SK40	14	44	100	AD/B	•
SK40.100.WK.16.ADB	SK40	16	48	100	AD/B	•
SK40.100.WK.18.ADB	SK40	18	50	100	AD/B	•
SK40.100.WK.20.ADB	SK40	20	52	100	AD/B	•
SK40.130.WK.06.ADB	SK40	6	25	130	AD/B	•
SK40.130.WK.08.ADB	SK40	8	28	130	AD/B	•
SK40.130.WK.10.ADB	SK40	10	35	130	AD/B	•
SK40.130.WK.12.ADB	SK40	12	42	130	AD/B	•
SK40.130.WK.14.ADB	SK40	14	44	130	AD/B	•
SK40.130.WK.16.ADB	SK40	16	48	130	AD/B	•
SK40.130.WK.18.ADB	SK40	18	50	130	AD/B	•
SK40.130.WK.20.ADB	SK40	20	52	130	AD/B	•
SK40.160.WK.06.ADB	SK40	6	25	160	AD/B	•
SK40.160.WK.08.ADB	SK40	8	28	160	AD/B	•
SK40.160.WK.10.ADB	SK40	10	35	160	AD/B	•
SK40.160.WK.12.ADB	SK40	12	42	160	AD/B	•
SK40.160.WK.14.ADB	SK40	14	44	160	AD/B	•
SK40.160.WK.16.ADB	SK40	16	48	160	AD/B	•
SK40.160.WK.18.ADB	SK40	18	50	160	AD/B	•
SK40.160.WK.20.ADB	SK40	20	52	160	AD/B	•

od průměr d = 25 se dvěma upínacími šrouby

d = 6 až 18 se dvěma chladicími kanály

d = 20 až 40 se čtyřmi chladicími kanály



Upínač Weldon s chladicími kanály pro upínací stopky



Upínač Weldon DIN 6359 pro upínací stopky DIN 1835-B

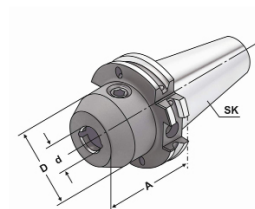

Název	Kužel	d	D	A		G 2,5 25.000 min ⁻¹
SK50.63.WK.06.ADB	SK50	6	25	63	AD/B	•
SK50.63.WK.08.ADB	SK50	8	28	63	AD/B	•
SK50.63.WK.10.ADB	SK50	10	35	63	AD/B	•
SK50.63.WK.12.ADB	SK50	12	42	63	AD/B	•
SK50.63.WK.14.ADB	SK50	14	44	63	AD/B	•
SK50.63.WK.16.ADB	SK50	16	48	63	AD/B	•
SK50.63.WK.18.ADB	SK50	18	50	63	AD/B	•
SK50.63.WK.20.ADB	SK50	20	52	63	AD/B	•
SK50.80.WK.25.ADB	SK50	25	65	80	AD/B	•
SK50.100.WK.06.ADB	SK50	6	25	100	AD/B	•
SK50.100.WK.08.ADB	SK50	8	28	100	AD/B	•
SK50.100.WK.10.ADB	SK50	10	35	100	AD/B	•
SK50.100.WK.12.ADB	SK50	12	42	100	AD/B	•
SK50.100.WK.14.ADB	SK50	14	44	100	AD/B	•
SK50.100.WK.16.ADB	SK50	16	48	100	AD/B	•
SK50.100.WK.18.ADB	SK50	18	50	100	AD/B	•
SK50.100.WK.20.ADB	SK50	20	52	100	AD/B	•
SK50.100.WK.32.ADB	SK50	32	72	100	AD/B	•
SK50.100.WK.40.ADB	SK50	40	80	100	AD/B	•

od průměr d = 25 se dvěma upínacími šrouby

d = 6 až 18 se dvěma chladicími kanály

d = 20 až 40 se čtyřmi chladicími kanály



Upínač Weldon s chladicími kanály pro upínací stopky



Upínač Weldon DIN 6359 pro upínací stopky DIN 1835-B

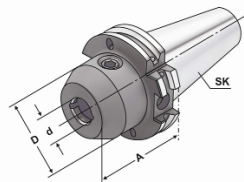

Název	Kužel	d	D	A		G 2,5 25.000 min ⁻¹
SK50.130.WK.06.ADB	SK50	6	25	130	AD/B	•
SK50.130.WK.08.ADB	SK50	8	28	130	AD/B	•
SK50.130.WK.10.ADB	SK50	10	35	130	AD/B	•
SK50.130.WK.12.ADB	SK50	12	42	130	AD/B	•
SK50.130.WK.14.ADB	SK50	14	44	130	AD/B	•
SK50.130.WK.16.ADB	SK50	16	48	130	AD/B	•
SK50.130.WK.18.ADB	SK50	18	50	130	AD/B	•
SK50.130.WK.20.ADB	SK50	20	52	130	AD/B	•
SK50.130.WK.25.ADB	SK50	25	65	130	AD/B	•
SK50.130.WK.32.ADB	SK50	32	72	130	AD/B	•
SK50.130.WK.40.ADB	SK50	40	80	130	AD/B	•
SK50.160.WK.06.ADB	SK50	6	25	160	AD/B	•
SK50.160.WK.08.ADB	SK50	8	28	160	AD/B	•
SK50.160.WK.10.ADB	SK50	10	35	160	AD/B	•
SK50.160.WK.12.ADB	SK50	12	42	160	AD/B	•
SK50.160.WK.14.ADB	SK50	14	44	160	AD/B	•
SK50.160.WK.16.ADB	SK50	16	48	160	AD/B	•
SK50.160.WK.18.ADB	SK50	18	50	160	AD/B	•
SK50.160.WK.20.ADB	SK50	20	52	160	AD/B	•
SK50.160.WK.25.ADB	SK50	25	65	160	AD/B	•
SK50.160.WK.32.ADB	SK50	32	72	160	AD/B	•
SK50.160.WK.40.ADB	SK50	40	80	160	AD/B	•

od průměr d = 25 se dvěma upínacími šrouby

d = 6 až 18 se dvěma chladicími kanály

d = 20 až 40 se čtyřmi chladicími kanály



Upínač Whistle Notch pro upínací stopky



Upínač Whistle Notch DIN 6359 pro upínací stopky DIN 1835-E

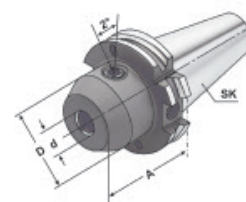

Název	Kužel	d	D	A		G 2,5 25.000 min ⁻¹
SK40.50.WN.06.ADB	SK40	6	25	50	AD/B	•
SK40.50.WN.08.ADB	SK40	8	28	50	AD/B	•
SK40.50.WN.10.ADB	SK40	10	35	50	AD/B	•
SK40.50.WN.12.ADB	SK40	12	42	50	AD/B	•
SK40.50.WN.14.ADB	SK40	14	44	50	AD/B	•
SK40.63.WN.16.ADB	SK40	16	48	63	AD/B	•
SK40.63.WN.18.ADB	SK40	18	50	63	AD/B	•
SK40.63.WN.20.ADB	SK40	20	52	63	AD/B	•
SK40.100.WN.25.ADB	SK40	25	65	100	AD/B	•
SK40.100.WN.32.ADB	SK40	32	72	100	AD/B	•
SK40.120.WN.40.ADB	SK40	40	80	120	AD/B	•
SK50.63.WN.06.ADB	SK50	6	25	63	AD/B	•
SK50.63.WN.08.ADB	SK50	8	28	63	AD/B	•
SK50.63.WN.10.ADB	SK50	10	35	63	AD/B	•
SK50.63.WN.12.ADB	SK50	12	42	63	AD/B	•
SK50.63.WN.14.ADB	SK50	14	44	63	AD/B	•
SK50.63.WN.16.ADB	SK50	16	48	63	AD/B	•
SK50.63.WN.18.ADB	SK50	18	50	63	AD/B	•
SK50.63.WN.20.ADB	SK50	20	52	63	AD/B	•
SK50.80.WN.25.ADB	SK50	25	65	80	AD/B	•
SK50.100.WN.32.ADB	SK50	32	72	100	AD/B	•
SK50.100.WN.40.ADB	SK50	40	80	100	AD/B	•

od průměr d = 25 se dvěma upínacími šrouby



Upínač pro nástroje s morse stopkou



DIN 228-1 Form B (DIN 6383)

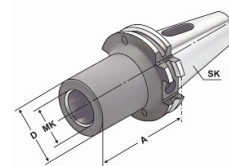

Název	Kužel	MK	D	A		G 6,3 15.000 min ⁻¹
SK40.50.MK.1.ADB	SK40	1	25	50	AD/B	•
SK40.50.MK.2.ADB	SK40	2	32	50	AD/B	•
SK40.70.MK.3.ADB	SK40	3	40	70	AD/B	•
SK40.95.MK.4.ADB	SK40	4	48	95	AD/B	•
SK50.45.MK.1.ADB	SK50	1	25	45	AD/B	•
SK50.60.MK.2.ADB	SK50	2	32	60	AD/B	•
SK50.65.MK.3.ADB	SK50	3	40	65	AD/B	•
SK50.95.MK.4.ADB	SK50	4	48	95	AD/B	•
SK50.105.MK.5.ADB	SK50	5	63	105	AD/B	•

Upínač pro nástroje s morse stopkou a závitem dle DIN228-A

DIN 228-1 Form A (DIN 6364)

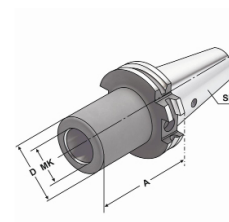

Název	Kužel	MK	D	A		G 6,3 15.000 min ⁻¹
SK40.50.MKS.1	SK40	1	25	50		•
SK40.50.MKS.2	SK40	2	32	50		•
SK40.70.MKS.3	SK40	3	40	70		•
SK40.95.MKS.4	SK40	4	48	95		•
SK40.110.MKS.4.D*	SK40	4	63	110		•
SK50.45.MKS.1	SK50	1	25	45		•
SK50.60.MKS.2	SK50	2	32	60		•
SK50.65.MKS.3	SK50	3	40	65		•
SK50.70.MKS.4	SK50	4	48	70		•
SK50.85.MKS.4.D*	SK50	4	63	85		•
SK50.100.MKS.5	SK50	5	63	100		•
SK50.118.MKS.5.D*	SK50	5	78	118		•

* s upínací drážkou dle DIN 2201



Upínač pro nástrčné frézy

DIN 6357

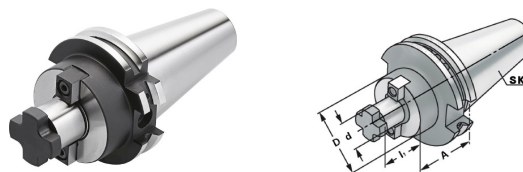

Název	Kužel	d	D	A	l ₁		G 2,5 25.000 min ⁻¹
SK40.35.N.16.AD	SK40	16	38	35	17	AD	•
SK40.35.N.22.AD	SK40	22	48	35	19	AD	•
SK40.40.N.27.AD	SK40	27	58	40	21	AD	•
SK40.50.N.32.AD	SK40	32	78	50	24	AD	•
SK40.50.N.40.AD	SK40	40	88	50	27	AD	•
SK40.35.N.16.ADB	SK40	16	38	35	17	AD/B	•
SK40.35.N.22.ADB	SK40	22	48	35	19	AD/B	•
SK40.40.N.27.ADB	SK40	27	58	40	21	AD/B	•
SK40.50.N.32.ADB	SK40	32	78	50	24	AD/B	•
SK40.50.N.40.ADB	SK40	40	88	50	27	AD/B	•
SK40.100.N.16.ADB	SK40	16	38	100	17	AD/B	•
SK40.100.N.22.ADB	SK40	22	48	100	19	AD/B	•
SK40.100.N.27.ADB	SK40	27	58	100	21	AD/B	•
SK40.100.N.32.ADB	SK40	32	78	100	24	AD/B	•
SK40.100.N.40.ADB	SK40	40	88	100	27	AD/B	•
SK40.130.N.16.ADB	SK40	16	38	130	17	AD/B	•
SK40.130.N.22.ADB	SK40	22	48	130	19	AD/B	•
SK40.130.N.27.ADB	SK40	27	58	130	21	AD/B	•
SK40.130.N.32.ADB	SK40	32	78	130	24	AD/B	•
SK40.130.N.40.ADB	SK40	40	88	130	27	AD/B	•
SK40.160.N.16.ADB	SK40	16	38	160	17	AD/B	•
SK40.160.N.22.ADB	SK40	22	48	160	19	AD/B	•
SK40.160.N.27.ADB	SK40	27	58	160	21	AD/B	•
SK40.160.N.32.ADB	SK40	32	78	160	24	AD/B	•
SK40.160.N.40.ADB	SK40	40	88	160	27	AD/B	•

d = 40/d = 60: pro velké průměry fréz se čtyřmi závitovými otvory dle DIN 2079

dodávka: s upínacím šroubem s křížovou hlavou a s upínacím šroubem s válcovou hlavou dle DIN 912 pro frézy s vnitřním chlazením

pro d = 60 pouze se čtyřmi upínacími šrouby dle DIN 912



S výstupními otvory chlazení na čele upínače



Upínač pro nástrčné frézy

DIN 6357

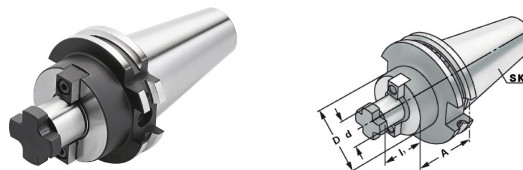

Název	Kužel	d	D	A	l ₁	G 2,5 25.000 min ⁻¹
SK50.45.N.16.ADB	SK50	16	38	45	17	AD/B
SK50.35.N.22.ADB	SK50	22	48	35	19	AD/B
SK50.40.N.27.ADB	SK50	27	58	40	21	AD/B
SK50.50.N.32.ADB	SK50	32	78	50	24	AD/B
SK50.50.N.40.ADB	SK50	40	88	50	27	AD/B
SK50.70.N.60.ADB	SK50	60	129	70	40	AD/B
SK50.100.N.16.ADB	SK50	16	38	100	17	AD/B
SK50.100.N.22.ADB	SK50	22	48	100	19	AD/B
SK50.100.N.27.ADB	SK50	27	58	100	21	AD/B
SK50.100.N.32.ADB	SK50	32	78	100	24	AD/B
SK50.100.N.40.ADB	SK50	40	88	100	27	AD/B
SK50.130.N.16.ADB	SK50	16	38	130	17	AD/B
SK50.130.N.22.ADB	SK50	22	48	130	19	AD/B
SK50.130.N.27.ADB	SK50	27	58	130	21	AD/B
SK50.130.N.32.ADB	SK50	32	78	130	24	AD/B
SK50.130.N.40.ADB	SK50	40	88	130	27	AD/B
SK50.160.N.16.ADB	SK50	16	38	160	17	AD/B
SK50.160.N.22.ADB	SK50	22	48	160	19	AD/B
SK50.160.N.27.ADB	SK50	27	58	160	21	AD/B
SK50.160.N.32.ADB	SK50	32	78	160	24	AD/B
SK50.160.N.40.ADB	SK50	40	88	160	27	AD/B
SK50.200.N.16.ADB	SK50	16	38	200	17	AD/B
SK50.200.N.22.ADB	SK50	22	48	200	19	AD/B
SK50.200.N.27.ADB	SK50	27	58	200	21	AD/B
SK50.200.N.32.ADB	SK50	32	78	200	24	AD/B
SK50.200.N.40.ADB	SK50	40	88	200	27	AD/B

d = 40/d = 60: pro velké průměry fréz se čtyřmi závitovými otvory dle DIN 2079

dodávka: s upínacím šroubem s křížovou hlavou a s upínacím šroubem s válcovou hlavou dle DIN 912 pro frézy s vnitřním chlazením

pro d = 60 pouze se čtyřmi upínacími šrouby dle DIN 912



S výstupními otvory chlazení na čele upínače



Upínač pro nástrčné frézy - kombi



DIN 6358

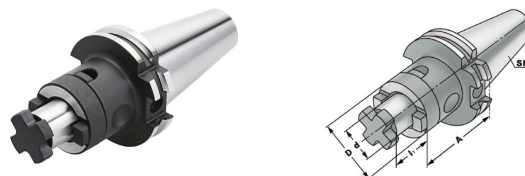

Název	Kužel	d	D	A	l ₁		G 6,3 15.000 min ⁻¹
SK40.55.NK.16.ADB	SK40	16	32	55	17	AD/B	•
SK40.55.NK.22.ADB	SK40	22	40	55	19	AD/B	•
SK40.55.NK.27.ADB	SK40	27	48	55	21	AD/B	•
SK40.60.NK.32.ADB	SK40	32	58	60	24	AD/B	•
SK40.60.NK.40.ADB	SK40	40	70	60	27	AD/B	•
SK40.100.NK.16.ADB	SK40	16	32	100	17	AD/B	•
SK40.100.NK.22.ADB	SK40	22	40	100	19	AD/B	•
SK40.100.NK.27.ADB	SK40	27	48	100	21	AD/B	•
SK40.100.NK.32.ADB	SK40	32	58	100	24	AD/B	•
SK40.100.NK.40.ADB	SK40	40	70	100	27	AD/B	•
SK40.160.NK.16.ADB	SK40	16	32	160	17	AD/B	•
SK40.160.NK.22.ADB	SK40	22	40	160	19	AD/B	•
SK40.160.NK.27.ADB	SK40	27	48	160	21	AD/B	•
SK40.160.NK.32.ADB	SK40	32	58	160	24	AD/B	•
SK40.160.NK.40.ADB	SK40	40	70	160	27	AD/B	•
SK50.55.NK.16.ADB	SK50	16	32	55	17	AD/B	•
SK50.55.NK.22.ADB	SK50	22	40	55	19	AD/B	•
SK50.55.NK.27.ADB	SK50	27	48	55	21	AD/B	•
SK50.55.NK.32.ADB	SK50	32	58	55	24	AD/B	•
SK50.55.NK.40.ADB	SK50	40	70	55	27	AD/B	•
SK50.100.NK.16.ADB	SK50	16	32	100	17	AD/B	•
SK50.100.NK.22.ADB	SK50	22	40	100	19	AD/B	•
SK50.100.NK.27.ADB	SK50	27	48	100	21	AD/B	•
SK50.100.NK.32.ADB	SK50	32	58	100	24	AD/B	•
SK50.100.NK.40.ADB	SK50	40	70	100	27	AD/B	•
SK50.160.NK.16.ADB	SK50	16	32	160	17	AD/B	•
SK50.160.NK.22.ADB	SK50	22	40	160	19	AD/B	•
SK50.160.NK.27.ADB	SK50	27	48	160	21	AD/B	•
SK50.160.NK.32.ADB	SK50	32	58	160	24	AD/B	•
SK50.160.NK.40.ADB	SK50	40	70	160	27	AD/B	•

dodávka: s upínacím šroubem, unašecím kroužkem a perem



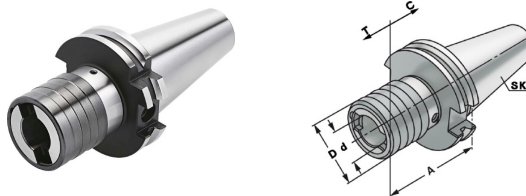

Závitořezná hlava s délkovou kompenzací

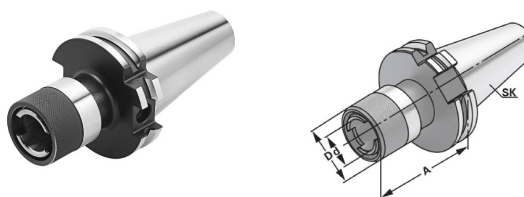

Název	Kužel	Rozsah	D	d	A	T	C	Upínač závitníku
SK40.314.Z.1.DK	SK40	M3 - M14	36	19	63	7	7	UZB1/UZS1
SK40.522.Z.2.DK	SK40	M5 - M22	53	31	97	12	12	UZB2/UZS2
SK40.1436.Z.3.DK	SK40	M14 - M36	78	48	156	17,5	17,5	UZB3/UZS3
SK50.314.Z.1.DK	SK50	M3 - M14	36	19	63	7	7	UZB1/UZS1
SK50.522.Z.2.DK	SK50	M5 - M22	53	31	97	12	12	UZB2/UZS2
SK50.1436.Z.3.DK	SK50	M14 - M36	78	48	140	17,5	17,5	UZB3/UZS3

Závitořezná hlava bez délkové kompenzace





Název	Kužel	Rozsah	D	d	A	Upínač závitníku	
SK40.314.Z.1.BK	SK40	M3 - M14	34	19	62	UZB1/UZS1	AD
SK40.522.Z.2.BK	SK40	M5 - M22	49	31	95	UZB2/UZS2	AD
SK40.1436.Z.3.BK	SK40	M14 - M36	74	48	130	UZB3/UZS3	AD
SK50.314.Z.1.BK	SK50	M3 - M14	34	19	60	UZB1/UZS1	AD
SK50.522.Z.2.BK	SK50	M5 - M22	49	31	85	UZB2/UZS2	AD
SK50.1436.Z.3.BK	SK50	M14 - M36	74	48	117	UZB3/UZS3	AD

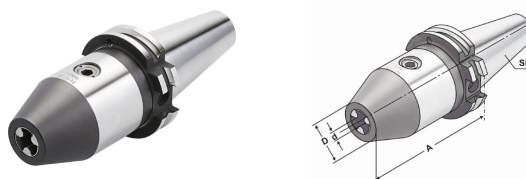

Vrtací hlavička



Název	Kužel	Rozsah	D	A			G 6,3 15.000 min ⁻¹
SK40.70.V.8.AD	SK40	0 - 8	36	70	AD	VT4	•
SK40.90.V.13.AD	SK40	1 - 13	50	90	AD	VT6	•
SK40.95.V.16.AD	SK40	2,5 - 16	50	95	AD	VT6	•
SK50.90.V.13.AD	SK50	1 - 13	50	90	AD	VT6	•
SK50.95.V.16.AD	SK50	2,5 - 16	50	95	AD	VT6	•

použití: pravé / levé otáčky
dodávka: bez montážního klíče

Upínač - redukce pro vrtací hlavičky

DIN 238

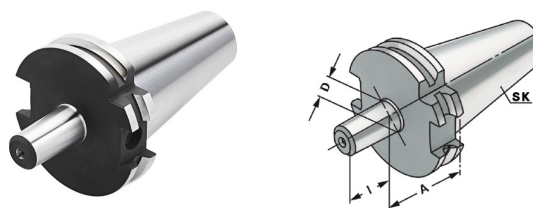

Název	Kužel	Název	D	A	l	G 6,3 15.000 min ⁻¹
SK40.25.B12	SK40	B12	25	18,5	•	
SK40.25.B16	SK40	B16	25	24	•	
SK40.35.B18	SK40	B18	35	32	•	
SK50.25.B12	SK50	B12	25	18,5	•	
SK50.25.B16	SK50	B16	25	24	•	
SK50.25.B18	SK50	B18	25	32	•	



Upínač pro frézy se závitem

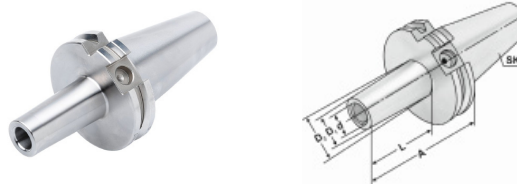

Název	Kužel	M	D ₂	D ₁	d	L	A		G 2,5 25.000 min ⁻¹
SK40.44.M.06.ADB	SK40	6	13	10	6,5	25	44	AD/B	•
SK40.69.M.06.ADB	SK40	6	13	10	6,5	50	69	AD/B	•
SK40.94.M.06.ADB	SK40	6	13	10	6,5	75	94	AD/B	•
SK40.44.M.08.ADB	SK40	8	15	13	8,5	25	44	AD/B	•
SK40.69.M.08.ADB	SK40	8	23	13	8,5	50	69	AD/B	•
SK40.94.M.08.ADB	SK40	8	23	13	8,5	75	94	AD/B	•
SK40.119.M.08.ADB	SK40	8	25	13	8,5	100	119	AD/B	•
SK40.24.M.10.ADB	SK40	10	18	18	10,5	5	24	AD/B	•
SK40.44.M.10.ADB	SK40	10	20	18	10,5	25	44	AD/B	•
SK40.69.M.10.ADB	SK40	10	23	18	10,5	50	69	AD/B	•
SK40.94.M.10.ADB	SK40	10	28	18	10,5	75	94	AD/B	•
SK40.119.M.10.ADB	SK40	10	32	18	10,5	100	119	AD/B	•
SK40.169.M.10.ADB	SK40	10	37	18	10,5	150	169	AD/B	•
SK40.24.M.12.ADB	SK40	12	21	21	12,5	5	24	AD/B	•
SK40.44.M.12.ADB	SK40	12	24	21	12,5	25	44	AD/B	•
SK40.69.M.12.ADB	SK40	12	24	21	12,5	50	69	AD/B	•
SK40.94.M.12.ADB	SK40	12	31	21	12,5	75	94	AD/B	•
SK40.119.M.12.ADB	SK40	12	33	21	12,5	100	119	AD/B	•
SK40.169.M.12.ADB	SK40	12	40	21	12,5	150	169	AD/B	•
SK40.24.M.16.ADB	SK40	16	29	29	17	5	24	AD/B	•
SK40.44.M.16.ADB	SK40	16	29	29	17	25	44	AD/B	•
SK40.69.M.16.ADB	SK40	16	34	29	17	50	69	AD/B	•
SK40.94.M.16.ADB	SK40	16	34	29	17	75	94	AD/B	•
SK40.119.M.16.ADB	SK40	16	36	29	17	100	119	AD/B	•
SK40.169.M.16.ADB	SK40	16	43	29	17	150	169	AD/B	•
SK50.69.M.08.ADB	SK50	8	23	13	8,5	50	69	AD/B	•
SK50.119.M.08.ADB	SK50	8	25	13	8,5	100	119	AD/B	•
SK50.169.M.08.ADB	SK50	8	30	13	8,5	150	169	AD/B	•
SK50.69.M.10.ADB	SK50	10	23	18	10,5	50	69	AD/B	•
SK50.119.M.10.ADB	SK50	10	32	18	10,5	100	119	AD/B	•
SK50.169.M.10.ADB	SK50	10	37	18	10,5	150	169	AD/B	•
SK50.69.M.12.ADB	SK50	12	24	21	12,5	50	69	AD/B	•
SK50.119.M.12.ADB	SK50	12	33	21	12,5	100	119	AD/B	•
SK50.169.M.12.ADB	SK50	12	40	21	12,5	150	169	AD/B	•
SK50.69.M.16.ADB	SK50	16	34	29	17	50	69	AD/B	•
SK50.119.M.16.ADB	SK50	16	36	29	17	100	119	AD/B	•
SK50.169.M.16.ADB	SK50	16	43	29	17	150	169	AD/B	•

Doporučené utahovací momenty

M6	10 Nm
M8	25 Nm
M10	40 Nm
M12	50 Nm
M16	60 Nm





Hydro upínač

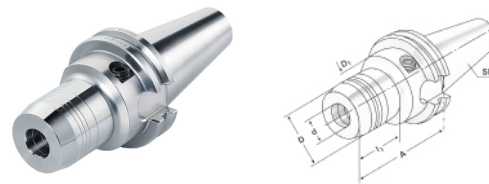

pro válcové upínací stopky DIN 1835 typ A+B+E a DIN 6535 typ HB+HE

(průměry nad 20 mm pouze s redukčním pouzdem)



Název	Kužel	d	D	D ₁	l ₁	l ₂	l ₃	A		G 2,5 25.000 min ⁻¹
SK40.68.H.06.ADB	SK40	6	26	50	37	10	33	68	AD/B	•
SK40.68.H.08.ADB	SK40	8	28	50	37	10	33	68	AD/B	•
SK40.72.H.10.ADB	SK40	10	30	50	42	10	37	72	AD/B	•
SK40.77.H.12.ADB	SK40	12	32	50	47	10	42	77	AD/B	•
SK40.77.H.14.ADB	SK40	14	34	50	47	10	42	77	AD/B	•
SK40.80.H.16.ADB	SK40	16	38	50	52	10	43	80	AD/B	•
SK40.80.H.18.ADB	SK40	18	40	50	52	10	43	80	AD/B	•
SK40.82.H.20.ADB	SK40	20	42	50	52	10	47	82	AD/B	•
SK40.117.H.25.ADB	SK40	25	50	63	58	10	51	117	AD/B	•
SK40.117.H.32.ADB	SK40	32	60	63	64	10	51	117	AD/B	•
SK40.110.H.06.ADB	SK40	6	26	50	37	10	33	110	AD/B	•
SK40.110.H.08.ADB	SK40	8	28	50	37	10	33	110	AD/B	•
SK40.110.H.10.ADB	SK40	10	30	50	42	10	37	110	AD/B	•
SK40.110.H.12.ADB	SK40	12	32	50	47	10	42	110	AD/B	•
SK40.110.H.14.ADB	SK40	14	34	50	47	10	42	110	AD/B	•
SK40.110.H.16.ADB	SK40	16	38	50	52	10	43	110	AD/B	•
SK40.110.H.18.ADB	SK40	18	40	50	52	10	43	110	AD/B	•
SK40.110.H.20.ADB	SK40	20	42	50	52	10	47	110	AD/B	•
SK40.150.H.06.ADB	SK40	6	26	50	42	10	110	150	AD/B	•
SK40.150.H.08.ADB	SK40	8	28	50	42	10	110	150	AD/B	•
SK40.150.H.10.ADB	SK40	10	30	50	42	10	110	150	AD/B	•
SK40.150.H.12.ADB	SK40	12	32	50	47	10	110	150	AD/B	•
SK40.150.H.14.ADB	SK40	14	34	50	47	10	110	150	AD/B	•
SK40.150.H.16.ADB	SK40	16	38	50	52	10	110	150	AD/B	•
SK40.150.H.18.ADB	SK40	18	40	50	52	10	110	150	AD/B	•
SK40.150.H.20.ADB	SK40	20	42	50	52	10	110	150	AD/B	•
SK40.150.H.25.ADB	SK40	25	50	63	58	10	94	150	AD/B	•

l₁ = maximální upínací délka

l₂ = maximální délkové nastavení

dodávka: bez montážního klíče





Hydro upínač

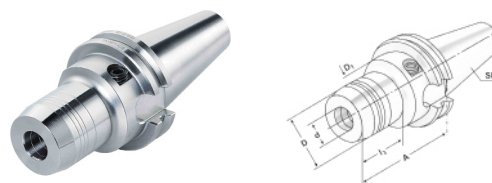

pro válcové upínací stopky DIN 1835 typ A+B+E a DIN 6535 typ HB+HE

(průměry nad 20 mm pouze s redukčním pouzdem)



Název	Kužel	d	D	D ₁	l ₁	l ₂	l ₃	A		G 2,5 25.000 min ⁻¹
SK50.68.H.06.ADB	SK50	6	26	50	37	10	33	68	AD/B	•
SK50.68.H.08.ADB	SK50	8	28	50	37	10	33	68	AD/B	•
SK50.72.H.10.ADB	SK50	10	30	50	42	10	37	72	AD/B	•
SK50.77.H.12.ADB	SK50	12	32	50	47	10	42	77	AD/B	•
SK50.77.H.14.ADB	SK50	14	34	50	47	10	42	77	AD/B	•
SK50.80.H.16.ADB	SK50	16	38	50	52	10	45	80	AD/B	•
SK50.80.H.18.ADB	SK50	18	40	50	52	10	45	80	AD/B	•
SK50.82.H.20.ADB	SK50	20	42	50	52	10	47	82	AD/B	•
SK50.87.H.25.ADB	SK50	25	50	63	58	10	52	87	AD/B	•
SK50.91.H.32.ADB	SK50	32	60	63	64	10	56	91	AD/B	•
SK50.110.H.06.ADB	SK50	6	26	50	37	10	33	110	AD/B	•
SK50.110.H.08.ADB	SK50	8	28	50	37	10	33	110	AD/B	•
SK50.110.H.10.ADB	SK50	10	30	50	42	10	37	110	AD/B	•
SK50.110.H.12.ADB	SK50	12	32	50	47	10	42	110	AD/B	•
SK50.110.H.14.ADB	SK50	14	34	50	47	10	42	110	AD/B	•
SK50.110.H.16.ADB	SK50	16	38	50	52	10	45	110	AD/B	•
SK50.110.H.18.ADB	SK50	18	40	50	52	10	45	110	AD/B	•
SK50.110.H.20.ADB	SK50	20	42	50	52	10	47	110	AD/B	•
SK50.110.H.25.ADB	SK50	25	50	63	58	10	52	110	AD/B	•
SK50.110.H.32.ADB	SK50	32	60	63	64	10	56	110	AD/B	•
SK50.150.H.06.ADB	SK50	6	26	50	37	10	110	150	AD/B	•
SK50.150.H.08.ADB	SK50	8	28	50	37	10	110	150	AD/B	•
SK50.150.H.10.ADB	SK50	10	30	50	42	10	110	150	AD/B	•
SK50.150.H.12.ADB	SK50	12	32	50	47	10	110	150	AD/B	•
SK50.150.H.14.ADB	SK50	14	34	50	47	10	110	150	AD/B	•
SK50.150.H.16.ADB	SK50	16	38	50	52	10	110	150	AD/B	•
SK50.150.H.18.ADB	SK50	18	40	50	52	10	110	150	AD/B	•
SK50.150.H.20.ADB	SK50	20	42	50	52	10	110	150	AD/B	•
SK50.150.H.25.ADB	SK50	25	50	50	52	10	110	150	AD/B	•
SK50.150.H.32.ADB	SK50	32	60	63	64	10	110	150	AD/B	•
SK50.150.H.40.ADB	SK50	40	63	63	74	10	131	150	AD/B	•

l₁ = maximální upínací délka

l₂ = maximální délkové nastavení

dodávka: bez montážního klíče



Upínač tepelný 4,5°

pro upínání nástrojů se stopkou TK a HSS

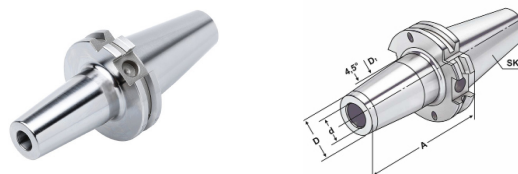

Název	Kužel	d	D	D ₁	l ₁	l ₂	A		G 2,5 25.000 min ⁻¹
SK40.80.T4.03.ADB	SK40	3	15	20	-	-	80	AD/B	•
SK40.120.T4.03.ADB	SK40	3	15	20	-	-	120	AD/B	•
SK40.160.T4.03.ADB	SK40	3	15	20	-	-	160	AD/B	•
SK40.80.T4.04.ADB	SK40	4	15	20	-	-	80	AD/B	•
SK40.120.T4.04.ADB	SK40	4	15	20	-	-	120	AD/B	•
SK40.160.T4.04.ADB	SK40	4	15	20	-	-	160	AD/B	•
SK40.80.T4.05.ADB	SK40	5	15	20	-	-	80	AD/B	•
SK40.120.T4.05.ADB	SK40	5	15	20	-	-	120	AD/B	•
SK40.160.T4.05.ADB	SK40	5	15	20	-	-	160	AD/B	•
SK40.80.T4.06.ADB	SK40	6	21	27	36	10	80	AD/B	•
SK40.120.T4.06.ADB	SK40	6	21	27	36	10	120	AD/B	•
SK40.160.T4.06.ADB	SK40	6	21	27	36	10	160	AD/B	•
SK40.80.T4.08.ADB	SK40	8	21	27	36	10	80	AD/B	•
SK40.120.T4.08.ADB	SK40	8	21	27	36	10	120	AD/B	•
SK40.160.T4.08.ADB	SK40	8	21	27	36	10	160	AD/B	•
SK40.80.T4.10.ADB	SK40	10	24	32	41	10	80	AD/B	•
SK40.120.T4.10.ADB	SK40	10	24	32	41	10	120	AD/B	•
SK40.160.T4.10.ADB	SK40	10	24	32	41	10	160	AD/B	•
SK40.80.T4.12.ADB	SK40	12	24	32	46	10	80	AD/B	•
SK40.120.T4.12.ADB	SK40	12	24	32	46	10	120	AD/B	•
SK40.160.T4.12.ADB	SK40	12	24	32	46	10	160	AD/B	•
SK40.80.T4.14.ADB	SK40	14	27	34	46	10	80	AD/B	•
SK40.120.T4.14.ADB	SK40	14	27	34	46	10	120	AD/B	•
SK40.160.T4.14.ADB	SK40	14	27	34	46	10	160	AD/B	•
SK40.80.T4.16.ADB	SK40	16	27	34	49	10	80	AD/B	•
SK40.120.T4.16.ADB	SK40	16	27	34	49	10	120	AD/B	•
SK40.160.T4.16.ADB	SK40	16	27	34	49	10	160	AD/B	•
SK40.80.T4.18.ADB	SK40	18	33	42	49	10	80	AD/B	•
SK40.120.T4.18.ADB	SK40	18	33	42	49	10	120	AD/B	•
SK40.160.T4.18.ADB	SK40	18	33	42	49	10	160	AD/B	•
SK40.80.T4.20.ADB	SK40	20	33	42	51	10	80	AD/B	•
SK40.120.T4.20.ADB	SK40	20	33	42	51	10	120	AD/B	•
SK40.160.T4.20.ADB	SK40	20	33	42	51	10	160	AD/B	•
SK40.100.T4.25.ADB	SK40	25	44	53	57	10	100	AD/B	•
SK40.120.T4.25.ADB	SK40	25	44	53	57	10	120	AD/B	•
SK40.160.T4.25.ADB	SK40	25	44	53	57	10	160	AD/B	•
SK40.100.T4.32.ADB	SK40	32	44	53	61	10	100	AD/B	•
SK40.120.T4.32.ADB	SK40	32	44	53	61	10	120	AD/B	•
SK40.160.T4.32.ADB	SK40	32	44	53	61	10	160	AD/B	•

pro průměry stopek 3, 4 a 5 mm pouze pro karbidové nástroje
 pro průměry stopek 3,4, a mm s tolerancí h4 a průměry stopek 6 až 32 s tolerancí h6
 vhodné pro přístroje, které používají ohřev indukční, kontaktní a teplým vzduchem

l₁ = maximální upínací délka

l₂ = maximální délkové nastavení



Upínač tepelný 4,5°

pro upínání nástrojů se stopkou TK a HSS

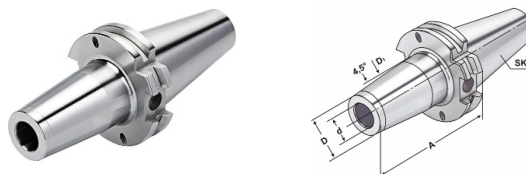

Název	Kužel	d	D	D ₁	l ₁	l ₂	A		G 2,5 25.000 min ⁻¹
SK50.80.T4.03.ADB	SK50	3	15	20	-	-	80	AD/B	•
SK50.80.T4.04.ADB	SK50	4	15	20	-	-	80	AD/B	•
SK50.80.T4.05.ADB	SK50	5	15	20	-	-	80	AD/B	•
SK50.80.T4.06.ADB	SK50	6	21	27	36	10	80	AD/B	•
SK50.120.T4.06.ADB	SK50	6	21	27	36	10	120	AD/B	•
SK50.160.T4.06.ADB	SK50	6	21	27	36	10	160	AD/B	•
SK50.200.T4.06.ADB	SK50	6	21	27	36	10	200	AD/B	•
SK50.80.T4.08.ADB	SK50	8	21	27	36	10	80	AD/B	•
SK50.120.T4.08.ADB	SK50	8	21	27	36	10	120	AD/B	•
SK50.160.T4.08.ADB	SK50	8	21	27	36	10	160	AD/B	•
SK50.200.T4.08.ADB	SK50	8	21	27	36	10	200	AD/B	•
SK50.80.T4.10.ADB	SK50	10	24	32	41	10	80	AD/B	•
SK50.120.T4.10.ADB	SK50	10	24	32	41	10	120	AD/B	•
SK50.160.T4.10.ADB	SK50	10	24	32	41	10	160	AD/B	•
SK50.200.T4.10.ADB	SK50	10	24	32	41	10	200	AD/B	•
SK50.80.T4.12.ADB	SK50	12	24	32	46	10	80	AD/B	•
SK50.120.T4.12.ADB	SK50	12	24	32	46	10	120	AD/B	•
SK50.160.T4.12.ADB	SK50	12	24	32	46	10	160	AD/B	•
SK50.200.T4.12.ADB	SK50	12	24	32	46	10	200	AD/B	•
SK50.80.T4.14.ADB	SK50	14	27	34	46	10	80	AD/B	•
SK50.120.T4.14.ADB	SK50	14	27	34	46	10	120	AD/B	•
SK50.160.T4.14.ADB	SK50	14	27	34	46	10	160	AD/B	•
SK50.200.T4.14.ADB	SK50	14	27	34	46	10	200	AD/B	•
SK50.80.T4.16.ADB	SK50	16	27	34	49	10	80	AD/B	•
SK50.120.T4.16.ADB	SK50	16	27	34	49	10	120	AD/B	•
SK50.160.T4.16.ADB	SK50	16	27	34	49	10	160	AD/B	•
SK50.200.T4.16.ADB	SK50	16	27	34	49	10	200	AD/B	•
SK50.80.T4.18.ADB	SK50	18	33	42	49	10	80	AD/B	•
SK50.120.T4.18.ADB	SK50	18	33	42	49	10	120	AD/B	•
SK50.160.T4.18.ADB	SK50	18	33	42	49	10	160	AD/B	•
SK50.200.T4.18.ADB	SK50	18	33	42	49	10	200	AD/B	•
SK50.80.T4.20.ADB	SK50	20	33	42	51	10	80	AD/B	•
SK50.120.T4.20.ADB	SK50	20	33	42	51	10	120	AD/B	•
SK50.160.T4.20.ADB	SK50	20	33	42	51	10	160	AD/B	•
SK50.200.T4.20.ADB	SK50	20	33	42	51	10	200	AD/B	•
SK50.100.T4.25.ADB	SK50	25	44	53	57	10	100	AD/B	•
SK50.160.T4.25.ADB	SK50	25	44	53	57	10	160	AD/B	•
SK50.200.T4.25.ADB	SK50	25	44	53	57	10	200	AD/B	•
SK50.100.T4.32.ADB	SK50	32	44	53	61	10	100	AD/B	•
SK50.160.T4.32.ADB	SK50	32	44	53	61	10	160	AD/B	•
SK50.200.T4.32.ADB	SK50	32	44	53	61	10	200	AD/B	•

pro průměry stopek 3, 4 a 5 mm pouze pro karbidové nástroje
 pro průměry stopek 3,4, a mm s tolerancí h4 a průměry stopek 6 až 32 s tolerancí h6
 vhodné pro přístroje, které používají ohřev indukční, kontaktní a teplým vzduchem

l₁ = maximální upínací délka

l₂ = maximální délkové nastavení



Upínač tepelný 4,5° s chladicími kanály



pro upínání nástrojů se stopkou TK a HSS

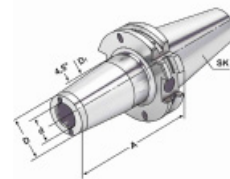

Název	Kužel	d	D	D ₁	l ₁	l ₂	A		G 2,5 25.000 min ⁻¹
SK40.80.TK4.06.ADB	SK40	6	21	27	36	10	80	AD/B	•
SK40.120.TK4.06.ADB	SK40	6	21	27	36	10	120	AD/B	•
SK40.80.TK4.08.ADB	SK40	8	21	27	36	10	80	AD/B	•
SK40.120.TK4.08.ADB	SK40	8	21	27	36	10	120	AD/B	•
SK40.80.TK4.10.ADB	SK40	10	24	32	41	10	80	AD/B	•
SK40.120.TK4.10.ADB	SK40	10	24	32	41	10	120	AD/B	•
SK40.80.TK4.12.ADB	SK40	12	24	32	46	10	80	AD/B	•
SK40.120.TK4.12.ADB	SK40	12	24	32	46	10	120	AD/B	•
SK40.80.TK4.14.ADB	SK40	14	27	34	46	10	80	AD/B	•
SK40.120.TK4.14.ADB	SK40	14	27	34	46	10	120	AD/B	•
SK40.80.TK4.16.ADB	SK40	16	27	34	49	10	80	AD/B	•
SK40.120.TK4.16.ADB	SK40	16	27	34	49	10	120	AD/B	•
SK40.80.TK4.18.ADB	SK40	18	33	42	49	10	80	AD/B	•
SK40.120.TK4.18.ADB	SK40	18	33	42	49	10	120	AD/B	•
SK40.80.TK4.20.ADB	SK40	20	33	42	51	10	80	AD/B	•
SK40.120.TK4.20.ADB	SK40	20	33	42	51	10	120	AD/B	•
SK40.100.TK4.25.ADB	SK40	25	44	53	57	10	80	AD/B	•
SK40.100.TK4.32.ADB	SK40	32	44	53	61	10	120	AD/B	•
SK50.80.TK4.06.ADB	SK50	6	21	27	36	10	80	AD/B	•
SK50.80.TK4.08.ADB	SK50	8	21	27	36	10	80	AD/B	•
SK50.80.TK4.10.ADB	SK50	10	24	32	41	10	80	AD/B	•
SK50.80.TK4.12.ADB	SK50	12	24	32	46	10	80	AD/B	•
SK50.80.TK4.14.ADB	SK50	14	27	34	46	10	80	AD/B	•
SK50.80.TK4.16.ADB	SK50	16	27	34	49	10	80	AD/B	•
SK50.80.TK4.18.ADB	SK50	18	33	42	49	10	80	AD/B	•
SK50.80.TK4.20.ADB	SK50	20	33	42	51	10	80	AD/B	•
SK50.100.TK4.25.ADB	SK50	25	44	53	57	10	100	AD/B	•
SK50.100.TK4.32.ADB	SK50	32	44	53	61	10	100	AD/B	•

pro průměry stopek 3, 4 a 5 mm pouze pro karbidové nástroje

l₁ = maximální upínací délka

l₂ = maximální délkové nastavení



Upínač tepelný 3°

pro upínání nástrojů se stopkou TK a HSS



Název	Kužel	d	D	D ₁	l ₁	l ₂	A		G 2,5 25.000 min ⁻¹
SK40.80.T3.03.ADB	SK40	3	9	15,5	-	-	80	AD/B	•
SK40.120.T3.03.ADB	SK40	3	9	19,5	-	-	120	AD/B	•
SK40.80.T3.04.ADB	SK40	4	10	16,5	-	-	80	AD/B	•
SK40.120.T3.04.ADB	SK40	4	10	20,5	-	-	120	AD/B	•
SK40.80.T3.05.ADB	SK40	5	11	17,5	-	-	80	AD/B	•
SK40.120.T3.05.ADB	SK40	5	11	21,5	-	-	120	AD/B	•
SK40.80.T3.06.ADB	SK40	6	12	18,5	36	10	80	AD/B	•
SK40.120.T3.06.ADB	SK40	6	12	22,5	36	10	120	AD/B	•
SK40.160.T3.06.ADB	SK40	6	12	26,5	36	10	160	AD/B	•
SK40.80.T3.08.ADB	SK40	8	14	20,5	36	10	80	AD/B	•
SK40.120.T3.08.ADB	SK40	8	14	24,5	36	10	120	AD/B	•
SK40.160.T3.08.ADB	SK40	8	14	28,5	36	10	160	AD/B	•
SK40.80.T3.10.ADB	SK40	10	16	22,5	41	10	80	AD/B	•
SK40.120.T3.10.ADB	SK40	10	16	26,5	41	10	120	AD/B	•
SK40.160.T3.10.ADB	SK40	10	16	30,5	41	10	160	AD/B	•
SK40.80.T3.12.ADB	SK40	12	18	24,5	46	10	80	AD/B	•
SK40.120.T3.12.ADB	SK40	12	18	28,5	46	10	120	AD/B	•
SK40.160.T3.12.ADB	SK40	12	18	32,5	46	10	160	AD/B	•

pro průměry stopek 3, 4 a 5 mm pouze pro karbidové nástroje

pro průměry stopek 3,4, a mm s tolerancí h4 a průměry stopek 6 až 32 s tolerancí h6 vhodné pro přístroje, které používají ohřev indukční, kontaktní a teplým vzduchem

l₁ = maximální upínací délka

l₂ = maximální délkové nastavení



Upínač - polotovar

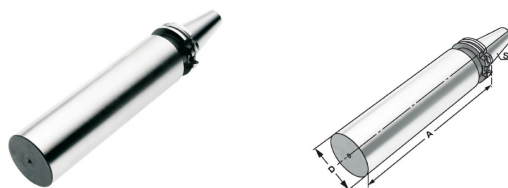

Název	Kužel	D	A
SK40.250.P.63	SK40	63	250
SK50.315.P.97	SK50	97	315

Kužel a příruba kalena a broušena. Těleso měkké pro další opracování.

Kontrolní trn

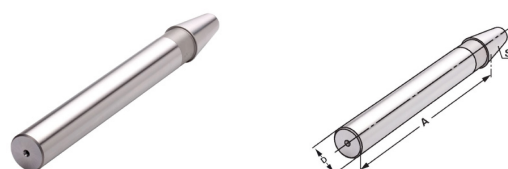

Název	Kužel	D	A	Max. odchylka soustřednosti
SK30.300.K.32	SK30	32	300	0,003
SK40.300.K.40	SK40	40	300	0,003
SK50.300.K.50	SK50	50	300	0,003

dodávka: s kontrolním protokolem

Dřevěná kazeta pro kontrolní trn



Název	Kužel	Rozměr
Kazeta pro kontrolní trn	SK30 / SK40 / SK50	460x130x115



Redukční pouzdro SK

pro DIN 69871, JIS B 6339, DIN 2080

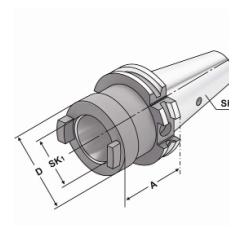

Název	Kužel	Kužel 1	D	A	G 6,3 15.000 min ⁻¹
SK40.50.R.30	SK40	SK30	50	50	•
SK40.100.R.40	SK40	SK40	63	100	•
SK50.70.R.40	SK50	SK40	70	70	•
SK50.120.R.50	SK50	SK50	97	120	•

dodávka s namontovaným upínacím šroubem pro krátký upínací kužel
včetně upínacího šroubu pro DIN 2080



Upínací kužely

DUAL KONTAKT DIN 69871

Upínací kužely jsou předvyváženy.

G 6.3 15.000 min⁻¹, G 2,5 25.000 min⁻¹
(G 2.5 vyšší vyvážení za příplatek)

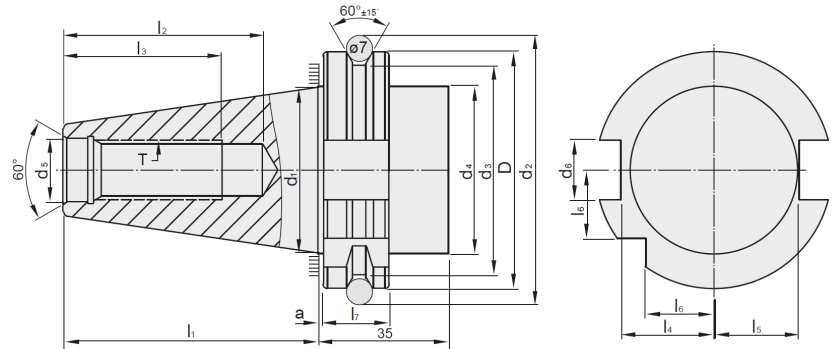

Kužel	D	d1	d2	d3	d4	d5	d6	d9	l1	l2	l3	l4	l5	l6	a	e1	e2	T
	0 - 0,1		± 0,05	0 - 0,5	max	H7	H12		0 - 0,3	min	min	0 - 0,4	0 - 0,4	0 - 0,3	0 - 0,005	± 0,1	max	max
ISO40	63,55	44,45	72,3	56,25	50	17	16,1	4	68,4	42,5	32	25	22,8	18,5	1	27	5	M16
ISO50	97,5	69,85	107,25	91,25	80	25	25,7	6	101,75	61,5	47	37,7	35,5	30	1,5	42	7	M24

S vnitřním chlazením přes límec – typ AD/B

Dodávka se šrouby bez hlavy v zavřené pozici.

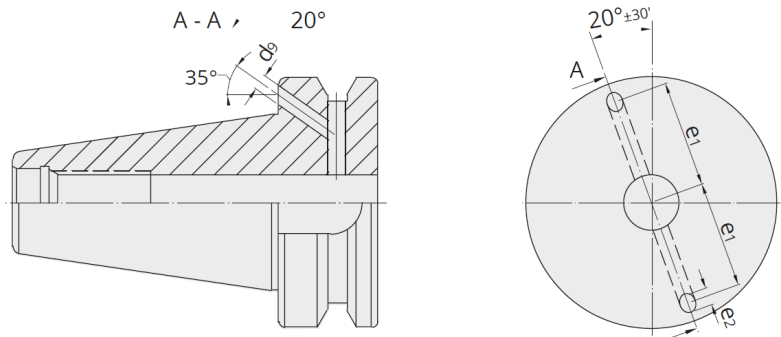

materiál: legovaná ocel cementovaná do hl. 0.8 ± 0.2 mm, kalená na 60 ± 2 HRC
s pevností v jádru min. 950 N/mm²
černěno a přesně broušeno

provedení AD/B: dodáváno v typu AD, typ B se šrouby bez hlavy v zavřené pozici

přesnost: kvalita kuželu < AT3 dle normy DIN 7187 a DIN 2080

NA-U-DUAL-SK-1-001-03/23



NA-U-DUAL-SK-1-001-03/23



NA-U-DUAL-SK-2-001-03/23



NA-U-DUAL-SK-2-002-03/23



NA-U-DUAL-SK-4-001-03/23



NA-U-DUAL-SK-5-001-03/23



NA-U-DUAL-SK-5-001-03/23



NA-U-DUAL-SK-6-001-03/23



NA-U-DUAL-SK-6-001-03/23



NA-U-DUAL-SK-6-002-03/23



NA-U-DUAL-SK-7-001-03/23



NA-U-DUAL-SK-8-001-03/23



NA-U-DUAL-SK-9-001-03/23



NA-U-DUAL-SK-9-001-03/23



NA-U-DUAL-SK-9-001-03/23



Kleštinový upínač pro kleštiny ER

DIN 6499 (ISO 15488)



Název	Kužel	Rozsah	D	A			G 2,5 25.000 min ⁻¹
SK40DK.63.ER.16.ADB	SK40DK	1 – 10 (ER 16)	32	63	AD/B	ER16K	•
SK40DK.60.ER.25.ADB	SK40DK	2 – 16 (ER 25)	42	60	AD/B	ER25K	•
SK40DK.70.ER.32.ADB	SK40DK	2 – 20 (ER 32)	50	70	AD/B	ER32K	•
SK40DK.80.ER.40.ADB	SK40DK	3 – 26 (ER 40)	63	80	AD/B	ER40K	•
SK40DK.100.ER.16.ADB	SK40DK	1 – 10 (ER 16)	32	100	AD/B	ER16K	•
SK40DK.100.ER.25.ADB	SK40DK	2 – 16 (ER 25)	42	100	AD/B	ER25K	•
SK40DK.100.ER.32.ADB	SK40DK	2 – 20 (ER 32)	50	100	AD/B	ER32K	•
SK40DK.100.ER.40.ADB	SK40DK	3 – 26 (ER 40)	63	100	AD/B	ER40K	•
SK40DK.160.ER.16.ADB	SK40DK	1 – 10 (ER 16)	32	160	AD/B	ER16K	•
SK40DK.160.ER.25.ADB	SK40DK	2 – 16 (ER 25)	42	160	AD/B	ER25K	•
SK40DK.160.ER.32.ADB	SK40DK	2 – 20 (ER 32)	50	160	AD/B	ER32K	•
SK40DK.160.ER.40.ADB	SK40DK	3 – 26 (ER 40)	63	160	AD/B	ER40K	•

dodávka: s vyváženou upínací maticí, bez montážního klíče

Silový kleštinový upínač

Pro upínací stopky DIN 1835 A+B+E a DIN 6535 HA+HB+HE

(pro větší než 20 mm pouze s redukčním pouzdrem)

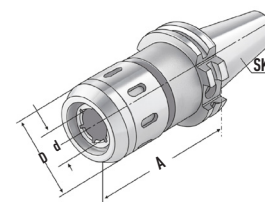

Název	Kužel	Rozsah	D	d	A			G 6,3 15.000 min ⁻¹
SK40DK.90.S.20.ADB	SK40DK	3 – 20 (RS20)	53	20	90	AD/B	RS20K	•
SK40DK.105.S.25.ADB	SK40DK	3 – 25 (RS25)	63	25	105	AD/B	RS25K	•
SK40DK.105.S.32.ADB	SK40DK	3 – 32 (RS32)	68	32	105	AD/B	RS32K	•

dodávka: bez montážního klíče

Velikost	20 mm	25 mm	32 mm
Upínací moment	50 - 70 Nm	80 - 100 Nm	80 - 100 Nm
Upínací síla	780 Nm	2000 Nm	2000 Nm



Upínač Weldon pro upínací stopky



Upínač Weldon DIN 6359 pro upínací stopky DIN 1835-B

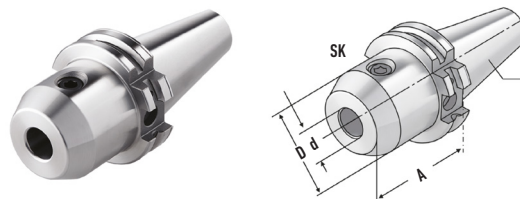

Název	Kužel	D	d	A		G 2,5 25.000 min ⁻¹
SK40DK.50.WE.06.ADB	SK40DK	25	6	50	AD/B	•
SK40DK.50.WE.08.ADB	SK40DK	28	8	50	AD/B	•
SK40DK.50.WE.10.ADB	SK40DK	35	10	50	AD/B	•
SK40DK.50.WE.12.ADB	SK40DK	42	12	50	AD/B	•
SK40DK.50.WE.14.ADB	SK40DK	44	14	50	AD/B	•
SK40DK.63.WE.16.ADB	SK40DK	48	16	63	AD/B	•
SK40DK.63.WE.18.ADB	SK40DK	50	18	63	AD/B	•
SK40DK.63.WE.20.ADB	SK40DK	52	20	63	AD/B	•
SK40DK.100.WE.25.ADB	SK40DK	65	25	100	AD/B	•
SK40DK.100.WE.32.ADB	SK40DK	72	32	100	AD/B	•
SK40DK.120.WE.40.ADB	SK40DK	80	40	120	AD/B	•
SK40DK.100.WE.06.ADB	SK40DK	25	6	100	AD/B	•
SK40DK.100.WE.08.ADB	SK40DK	28	8	100	AD/B	•
SK40DK.100.WE.10.ADB	SK40DK	35	10	100	AD/B	•
SK40DK.100.WE.12.ADB	SK40DK	42	12	100	AD/B	•
SK40DK.100.WE.14.ADB	SK40DK	44	14	100	AD/B	•
SK40DK.100.WE.16.ADB	SK40DK	48	16	100	AD/B	•
SK40DK.100.WE.18.ADB	SK40DK	50	18	100	AD/B	•
SK40DK.100.WE.20.ADB	SK40DK	52	20	100	AD/B	•

od průměru 25 se dvěma upínacími šrouby



Upínač Weldon s chladicími kanály pro upínací stopky



Upínač Weldon DIN 6359 pro upínací stopky DIN 1835-B

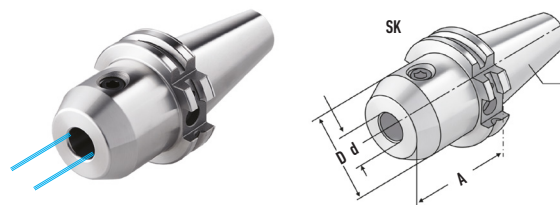

Název	Kužel	D	d	A		G 2,5 25.000 min ⁻¹
SK40DK.50.WK.06.ADB	SK40DK	25	6	50	AD/B	•
SK40DK.50.WK.08.ADB	SK40DK	28	8	50	AD/B	•
SK40DK.50.WK.10.ADB	SK40DK	35	10	50	AD/B	•
SK40DK.50.WK.12.ADB	SK40DK	42	12	50	AD/B	•
SK40DK.50.WK.14.ADB	SK40DK	44	14	50	AD/B	•
SK40DK.63.WK.16.ADB	SK40DK	48	16	63	AD/B	•
SK40DK.63.WK.18.ADB	SK40DK	50	18	63	AD/B	•
SK40DK.63.WK.20.ADB	SK40DK	52	20	63	AD/B	•

d = 6 až 18 se dvěma chladicími kanály

d = 20 se čtyřmi chladicími kanály



Upínač pro nástroje s morse stopkou

DIN 228-1 Form B

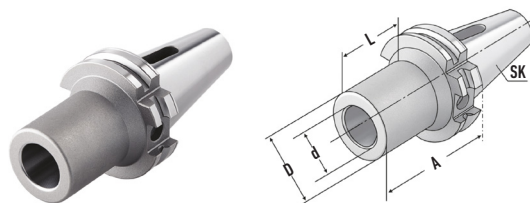



Název	Kužel	MK	D	L	A		G 6,3 15.000 min ⁻¹
SK40DK.50.MK.1.ADB	SK40DK	1	25	31	50	AD/B	•
SK40DK.50.MK.2.ADB	SK40DK	2	32	19	50	AD/B	•
SK40DK.70.MK.3.ADB	SK40DK	3	40	44	70	AD/B	•
SK40DK.95.MK.4.ADB	SK40DK	4	48	76	95	AD/B	•

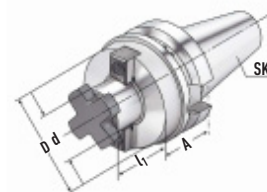

Upínač pro nástrčné frézy

DIN 6357



Název	Kužel	d	D	A	l ₁		G 2,5 25.000 min ⁻¹
SK40DK.35.N.16.ADB	SK40DK	16	38	35	17	AD/B	•
SK40DK.35.N.22.ADB	SK40DK	22	48	35	19	AD/B	•
SK40DK.40.N.27.ADB	SK40DK	27	58	40	21	AD/B	•
SK40DK.50.N.32.ADB	SK40DK	32	78	50	24	AD/B	•
SK40DK.50.N.40.ADB	SK40DK	40	88	50	27	AD/B	•
SK40DK.100.N.16.ADB	SK40DK	16	38	100	17	AD/B	•
SK40DK.100.N.22.ADB	SK40DK	22	48	100	19	AD/B	•
SK40DK.100.N.27.ADB	SK40DK	27	58	100	21	AD/B	•

d = 40: pro velké průměry fréz se čtyřmi závitovými otvory dle DIN 2079

dodávka: s upínacím šroubem s křížovou hlavou a s upínacím šroubem s válcovou hlavou dle DIN 912 pro frézy s vnitřním chlazením



S výstupními otvory chlazení na čele upínače

Upínač pro nástrčné frézy - kombi

DIN 6358





Název	Kužel	d	D	A	l ₁		G 6,3 15.000 min ⁻¹
SK40DK.55.NK.16.ADB	SK40DK	16	32	55	17	AD/B	•
SK40DK.55.NK.22.ADB	SK40DK	22	40	55	19	AD/B	•
SK40DK.55.NK.27.ADB	SK40DK	27	48	55	21	AD/B	•
SK40DK.60.NK.32.ADB	SK40DK	32	58	60	24	AD/B	•
SK40DK.60.NK.40.ADB	SK40DK	40	70	60	27	AD/B	•

dodávka: s upínacím šroubem, unašecím kroužkem a perem



Vrtací hlavička



Název	Kužel	Rozsah	D	A			G 6,3 15.000 min ⁻¹
SK40DK.90.V.13.ADB	SK40DK	1 - 13	50	90	AD/B	VT6	•
SK40DK.95.V.16.ADB	SK40DK	2,5 - 16	50	95	AD/B	VT6	•

použití: pravé / levé otáčky
dodávka: bez montážního klíče

Závitořezná hlava s délkovou kompenzací

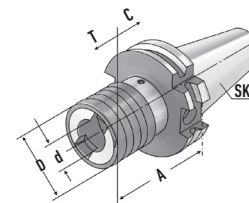

Název	Kužel	Rozsah	D	d	A	T	C	Upínač závitníku
SK40DK.314.Z.1.DK	SK40DK	M3 - M14	36	19	63	7	7	UZB1/UZS1
SK40DK.522.Z.2.DK	SK40DK	M5 - M22	53	31	97	12	12	UZB2/UZS2



Upínač pro frézy se závitem

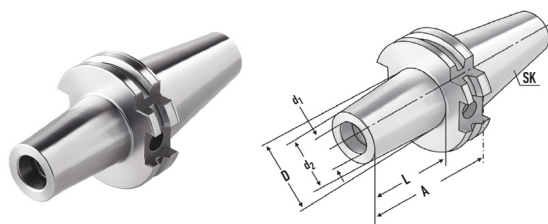

Název	Kužel	M	D	d ₁	d ₂	L	A		G 2,5 25.000 min ⁻¹
SK40DK.44.M.12.ADB	SK40DK	12	24	21	12,5	25	44	AD/B	•
SK40DK.69.M.12.ADB	SK40DK	12	24	21	12,5	50	69	AD/B	•
SK40DK.94.M.12.ADB	SK40DK	12	31	21	12,5	75	94	AD/B	•
SK40DK.24.M.16.ADB	SK40DK	16	29	29	17	5	24	AD/B	•
SK40DK.44.M.16.ADB	SK40DK	16	29	29	17	25	44	AD/B	•
SK40DK.69.M.16.ADB	SK40DK	16	34	29	17	50	69	AD/B	•
SK40DK.94.M.16.ADB	SK40DK	16	34	29	17	75	94	AD/B	•

Doporučené utahovací momenty

M6	10 Nm
M8	25 Nm
M10	40 Nm
M12	50 Nm
M16	60 Nm





Hydro upínač

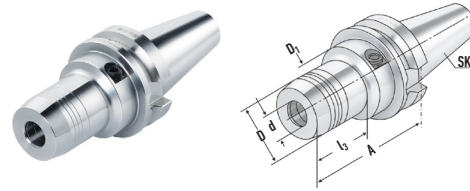

pro válcové upínací stopky DIN 1835 typ A+B+E a DIN 6535 typ HB+HE

(průměry nad 20 mm pouze s redukčním pouzdem)



Název	Kužel	d	D	D ₁	l ₁	l ₂	l ₃	A		G 2,5 25.000 min ⁻¹
SK40DK.68.H.06.ADB	SK40DK	6	26	50	37	10	33	68	AD/B	•
SK40DK.68.H.08.ADB	SK40DK	8	28	50	37	10	29	68	AD/B	•
SK40DK.72.H.10.ADB	SK40DK	10	30	50	42	10	37	72	AD/B	•
SK40DK.77.H.12.ADB	SK40DK	12	32	50	47	10	42	77	AD/B	•
SK40DK.77.H.14.ADB	SK40DK	14	34	50	47	10	42	77	AD/B	•
SK40DK.80.H.16.ADB	SK40DK	16	38	50	52	10	43	80	AD/B	•
SK40DK.80.H.18.ADB	SK40DK	18	40	50	52	10	43	80	AD/B	•
SK40DK.82.H.20.ADB	SK40DK	20	42	50	52	10	47	82	AD/B	•
SK40DK.117.H.25.ADB	SK40DK	25	50	63	58	10	51	117	AD/B	•
SK40DK.117.H.32.ADB	SK40DK	32	60	63	64	10	51	117	AD/B	•

l₁ = maximální upínací délka

l₂ = maximální délkové nastavení

dodávka: bez montážního klíče



Upínač tepelný 4,5°

pro upínání nástrojů se stopkou TK a HSS

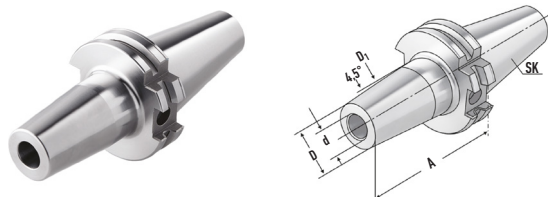

Název	Kužel	d	D	D ₁	l ₁	l ₂	A		G 2,5 25.000 min ⁻¹
SK40DK.80.T4.03.ADB	SK40DK	3	11	15	-	-	80	AD/B	•
SK40DK.80.T4.04.ADB	SK40DK	4	14	22	-	-	80	AD/B	•
SK40DK.80.T4.05.ADB	SK40DK	5	16	22	-	-	80	AD/B	•
SK40DK.80.T4.06.ADB	SK40DK	6	21	27	36	10	80	AD/B	•
SK40DK.80.T4.08.ADB	SK40DK	8	21	27	36	10	80	AD/B	•
SK40DK.80.T4.10.ADB	SK40DK	10	24	32	41	10	80	AD/B	•
SK40DK.80.T4.12.ADB	SK40DK	12	24	32	46	10	80	AD/B	•
SK40DK.80.T4.14.ADB	SK40DK	14	27	34	46	10	80	AD/B	•
SK40DK.80.T4.16.ADB	SK40DK	16	27	34	49	10	80	AD/B	•
SK40DK.80.T4.18.ADB	SK40DK	18	33	42	49	10	80	AD/B	•
SK40DK.80.T4.20.ADB	SK40DK	20	33	42	51	10	80	AD/B	•
SK40DK.100.T4.25.ADB	SK40DK	25	44	53	57	10	100	AD/B	•
SK40DK.100.T4.32.ADB	SK40DK	32	44	53	61	10	100	AD/B	•

pro průměry stopek 3, 4 a 5 mm pouze pro karbidové nástroje

pro průměry stopek 3, 4, a mm s tolerancí h4 a průměry stopek 6 až 32 s tolerancí h6 vhodné pro přístroje, které používají ohřev indukční, kontaktní a teplým vzduchem

l₁ = maximální upínací délka

l₂ = maximální délkové nastavení



Upínač - polotovar

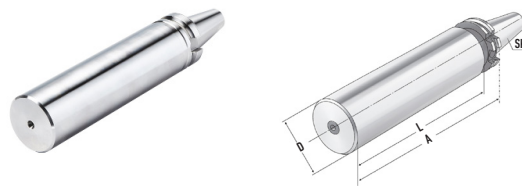

Název	Kužel	D	L	A
SK40DK.250.P.63	SK40DK	63	215	250

Kužel a příruba kalena a broušena. Těleso měkké pro další opracování.

Kontrolní trn

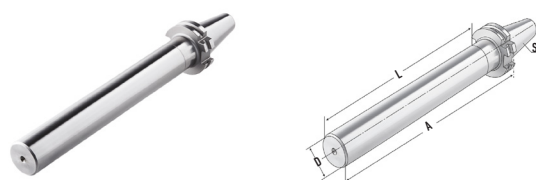

Název	Kužel	D	L	A	Max. odchylka soustřednosti
SK40DK.300.K.40	SK40DK	40	256	300	0,003

dodávka: s kontrolním protokolem

Dřevěná kazeta pro kontrolní trn



Název	Kužel	Rozměr
Kazeta pro kontrolní trn	SK30 / SK40 / SK50	460x130x115



Upínací kužely

JIS B 6339 (MAS 403 BT)

ETGS

Upínací kužely jsou předvyváženy.

G 6.3 15.000 min⁻¹, G 2,5 25.000 min⁻¹
(G 2.5 vyšší vyvážení za příplatek)

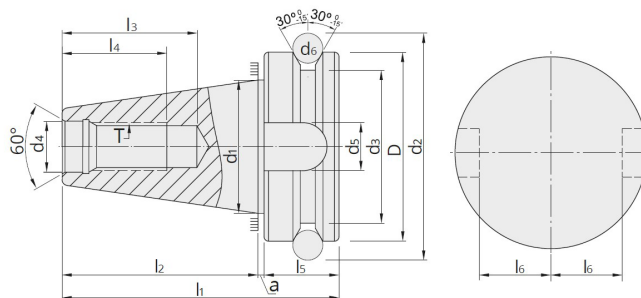

Kužel	D	d ₁	d ₂	d ₃	d ₄	d ₅	d ₆	d ₉	a	l ₁	l ₂	l ₃	l ₄	l ₅	l ₆	e ₁	e ₂	T
	H8				H8	H12		H12	± 0,005		± 0,2	min	min		⁰ _{-0,2}	± 0,1	max	
BT30	46	31,7	56,14	38	12,5	16,1	8	-	2	70,4	48,4	34	24	20	16,3	-	-	M12
BT40	63	44,45	75,679	53	17,0	16,1	10	4	2	92,4	65,4	43	30	25	22,6	27	5	M16
BT50	100	69,85	119,02	85	25,0	25,7	15	6	3	139,8	101,8	62	45	35	35,4	42	7	M24

S vnitřním chlazením přes límec - typ AD/B

Dodávka se šrouby bez hlavy v zavřené pozici.

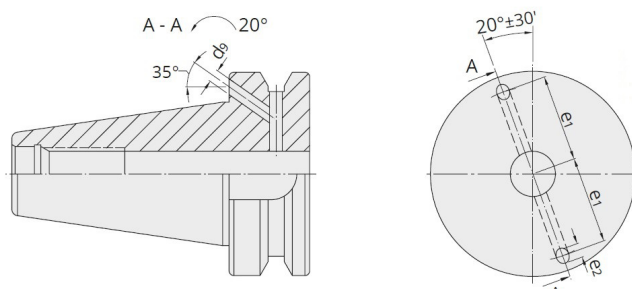

materiál: legovaná ocel cementovaná do hl. 0.8 ± 0.2 mm, kalená na 60 ± 2 HRC
s pevností v jádru min. 950 N/mm^2
černěno a přesně broušeno

provedení AD/B: dodáváno v typu AD, typ B se šrouby bez hlavy v zavřené pozici

přesnost: kvalita kuželu < AT3 dle normy DIN 7187 a DIN 2080



NA-U-BT-1-001-02/23



NA-U-BT-1-002-02/23



NA-U-BT-1-002-02/23



NA-U-BT-2-001-02/23



NA-U-BT-2-002-02/23



NA-U-BT-3-001-02/23



NA-U-BT-4-001-02/23



NA-U-BT-4-001-02/23



NA-U-BT-5-001-02/23



NA-U-BT-5-002-02/23



NA-U-BT-6-001-02/23



NA-U-BT-6-001-02/23



NA-U-BT-6-002-02/23



NA-U-BT-6-002-02/23



NA-U-BT-6-003-02/23



NA-U-BT-7-001-02/23



NA-U-BT-8-001-02/23



NA-U-BT-8-002-02/23



NA-U-BT-8-003-02/23



NA-U-BT-9-001-02/23



NA-U-BT-9-001-02/23



NA-U-BT-9-001-02/23





NA-U-BT-9-002-02/23

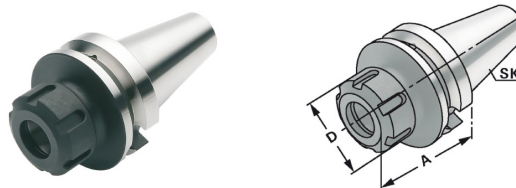

Kleštinový upínač pro kleštiny ER

DIN 6499 (ISO 15488)



Katalogové číslo	Kužel	Rozsah	D	A			G 2,5 25.000 min ⁻¹
BT40.63.ER.16.AD	BT40	1 – 10 (ER 16)	32	63	AD	ER16K	•
BT40.70.ER.20.AD	BT40	2 – 13 (ER 20)	35	70	AD	ER20K	•
BT40.60.ER.25.AD	BT40	2 – 16 (ER 25)	42	60	AD	ER25K	•
BT40.70.ER.32.AD	BT40	2 – 20 (ER 32)	50	70	AD	ER32K	•
BT40.80.ER.40.AD	BT40	3 – 26 (ER 40)	63	80	AD	ER40K	•
BT40.100.ER.16.AD	BT40	1 – 10 (ER 16)	32	100	AD	ER16K	•
BT40.100.ER.20.AD	BT40	2 – 13 (ER 20)	35	100	AD	ER20K	•
BT40.100.ER.25.AD	BT40	2 – 16 (ER 25)	42	100	AD	ER25K	•
BT40.100.ER.32.AD	BT40	2 – 20 (ER 32)	50	100	AD	ER32K	•
BT40.100.ER.40.AD	BT40	3 – 26 (ER 40)	63	100	AD	ER40K	•
BT40.63.ER.16.ADB	BT40	1 – 10 (ER 16)	32	63	AD/B	ER16K	•
BT40.70.ER.20.ADB	BT40	2 – 13 (ER 20)	35	70	AD/B	ER20K	•
BT40.60.ER.25.ADB	BT40	2 – 16 (ER 25)	42	60	AD/B	ER25K	•
BT40.70.ER.32.ADB	BT40	2 – 20 (ER 32)	50	70	AD/B	ER32K	•
BT40.80.ER.40.ADB	BT40	3 – 26 (ER 40)	63	80	AD/B	ER40K	•
BT40.100.ER.16.ADB	BT40	1 – 10 (ER 16)	32	100	AD/B	ER16K	•
BT40.100.ER.20.ADB	BT40	2 – 13 (ER 20)	35	100	AD/B	ER20K	•
BT40.100.ER.25.ADB	BT40	2 – 16 (ER 25)	42	100	AD/B	ER25K	•
BT40.100.ER.32.ADB	BT40	2 – 20 (ER 32)	50	100	AD/B	ER32K	•
BT40.100.ER.40.ADB	BT40	3 – 26 (ER 40)	63	100	AD/B	ER40K	•
BT40.160.ER.16.ADB	BT40	1 – 10 (ER 16)	32	160	AD/B	ER16K	•
BT40.160.ER.20.ADB	BT40	2 – 13 (ER 20)	35	160	AD/B	ER20K	•
BT40.160.ER.25.ADB	BT40	2 – 16 (ER 25)	42	160	AD/B	ER25K	•
BT40.160.ER.32.ADB	BT40	2 – 20 (ER 32)	50	160	AD/B	ER32K	•
BT40.160.ER.40.ADB	BT40	3 – 26 (ER 40)	63	160	AD/B	ER40K	•
BT40.200.ER.16.ADB	BT40	1 – 10 (ER 16)	32	200	AD/B	ER16K	•
BT40.200.ER.20.ADB	BT40	2 – 13 (ER 20)	35	200	AD/B	ER20K	•
BT40.200.ER.25.ADB	BT40	2 – 16 (ER 25)	42	200	AD/B	ER25K	•
BT40.200.ER.32.ADB	BT40	2 – 20 (ER 32)	50	200	AD/B	ER32K	•
BT40.200.ER.40.ADB	BT40	3 – 26 (ER 40)	63	200	AD/B	ER40K	•



dodávka: s vyváženou upínací maticí, bez montážního klíče

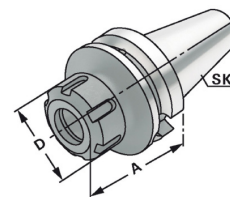

Kleštinový upínač pro kleštiny ER

DIN 6499 (ISO 15488)



Katalogové číslo	Kužel	Rozsah	D	A			G 2,5 25.000 min ⁻¹
BT50.70.ER.20.ADB	BT50	2 – 13 (ER 20)	35	70	AD/B	ER20K	•
BT50.70.ER.25.ADB	BT50	2 – 16 (ER 25)	42	70	AD/B	ER25K	•
BT50.70.ER.32.ADB	BT50	2 – 20 (ER 32)	50	70	AD/B	ER32K	•
BT50.80.ER.40.ADB	BT50	3 – 26 (ER 40)	63	80	AD/B	ER40K	•
BT50.100.ER.16.ADB	BT50	1 – 10 (ER 16)	32	100	AD/B	ER16K	•
BT50.100.ER.20.ADB	BT50	2 – 13 (ER 20)	35	100	AD/B	ER20K	•
BT50.100.ER.25.ADB	BT50	2 – 16 (ER 25)	42	100	AD/B	ER25K	•
BT50.100.ER.32.ADB	BT50	2 – 20 (ER 32)	50	100	AD/B	ER32K	•
BT50.100.ER.40.ADB	BT50	3 – 26 (ER 40)	63	100	AD/B	ER40K	•
BT50.160.ER.16.ADB	BT50	1 – 10 (ER 16)	32	160	AD/B	ER16K	•
BT50.160.ER.20.ADB	BT50	2 – 13 (ER 20)	35	160	AD/B	ER20K	•
BT50.160.ER.25.ADB	BT50	2 – 16 (ER 25)	42	160	AD/B	ER25K	•
BT50.160.ER.32.ADB	BT50	2 – 20 (ER 32)	50	160	AD/B	ER32K	•
BT50.160.ER.40.ADB	BT50	3 – 26 (ER 40)	63	160	AD/B	ER40K	•
BT50.200.ER.16.ADB	BT50	1 – 10 (ER 16)	32	200	AD/B	ER16K	•
BT50.200.ER.20.ADB	BT50	2 – 13 (ER 20)	35	200	AD/B	ER20K	•
BT50.200.ER.25.ADB	BT50	2 – 16 (ER 25)	42	200	AD/B	ER25K	•
BT50.200.ER.32.ADB	BT50	2 – 20 (ER 32)	50	200	AD/B	ER32K	•
BT50.200.ER.40.ADB	BT50	3 – 26 (ER 40)	63	200	AD/B	ER40K	•

dodávka: s vyváženou upínací maticí, bez montážního klíče



Kleštinový upínač úzký pro kleštiny ER



DIN 6499 (ISO 15488)

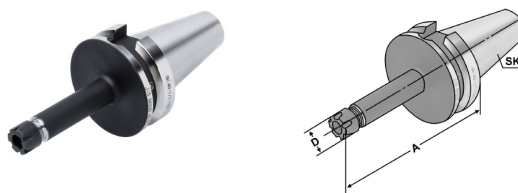

Katalogové číslo	Kužel	Rozsah	D	A			G 2,5 25.000 min ⁻¹
BT40.63.ERM.11.ADB	BT40	1 – 7 (ER 11)	16	63	AD/B	ER11MK	•
BT40.100.ERM.11.ADB	BT40	1 – 7 (ER 11)	16	100	AD/B	ER11MK	•
BT40.160.ERM.11.ADB	BT40	1 – 7 (ER 11)	16	160	AD/B	ER11MK	•
BT40.55.ERM.16.ADB	BT40	1 – 10 (ER 16)	22	55	AD/B	ER16MK	•
BT40.100.ERM.16.ADB	BT40	1 – 10 (ER 16)	22	100	AD/B	ER16MK	•
BT40.160.ERM.16.ADB	BT40	1 – 10 (ER 16)	22	160	AD/B	ER16MK	•
BT40.70.ERM.20.ADB	BT40	2 – 13 (ER 20)	28	70	AD/B	ER20MK	•
BT40.100.ERM.20.ADB	BT40	2 – 13 (ER 20)	28	100	AD/B	ER20MK	•
BT40.160.ERM.20.ADB	BT40	2 – 13 (ER 20)	28	160	AD/B	ER20MK	•
BT40.70.ERM.25.ADB	BT40	2 – 16 (ER 25)	35	70	AD/B	ER25MK	•
BT40.100.ERM.25.ADB	BT40	2 – 16 (ER 25)	35	100	AD/B	ER25MK	•
BT40.160.ERM.25.ADB	BT40	2 – 16 (ER 25)	35	160	AD/B	ER25MK	•

dodávka: s vyváženou upínací maticí, bez montážního klíče

Silový kleštinový upínač

pro upínací stopky DIN 1835 A+B+E a DIN 6535 HA+HB+HE

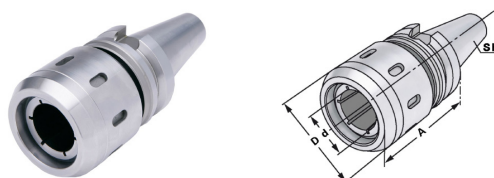

Katalogové číslo	Kužel	Rozsah	D	d	A			G 6,3 15.000 min ⁻¹
BT40.90.S.20.ADB	BT40	3 – 20 (RS20)	53	20	90	AD/B	RS20K	•
BT40.90.S.25.ADB	BT40	3 – 25 (RS25)	63	25	90	AD/B	RS32K	•
BT40.90.S.32.ADB	BT40	3 – 32 (RS32)	68	32	90	AD/B	RS32K	•
BT50.95.S.20.ADB	BT50	3 – 20 (RS20)	53	20	95	AD/B	RS20K	•
BT50.95.S.25.ADB	BT50	3 – 25 (RS25)	63	25	95	AD/B	RS32K	•
BT50.90.S.32.ADB	BT50	3 – 32 (RS32)	68	32	90	AD/B	RS32K	•

dodávka: s vyváženou upínací maticí, bez montážního klíče

Velikost	20 mm	25 mm	32 mm
Upínací moment	50 – 70 Nm	80 – 100 Nm	80 – 100 Nm
Upínací síla	780 Nm	2000 Nm	2000 Nm



Upínač Weldon pro upínací stopky



Upínač Weldon DIN 6359 pro upínací stopky DIN 1835-B

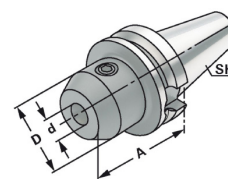

Katalogové číslo	Kužel	D	d	A		G 2,5 25.000 min ⁻¹
BT40.50.WE.06.AD	BT40	25	6	50	AD	•
BT40.50.WE.08.AD	BT40	28	8	50	AD	•
BT40.63.WE.10.AD	BT40	35	10	63	AD	•
BT40.63.WE.12.AD	BT40	42	12	63	AD	•
BT40.63.WE.14.AD	BT40	44	14	63	AD	•
BT40.63.WE.16.AD	BT40	48	16	63	AD	•
BT40.63.WE.18.AD	BT40	50	18	63	AD	•
BT40.63.WE.20.AD	BT40	52	20	63	AD	•
BT40.90.WE.25.AD	BT40	65	25	90	AD	•
BT40.100.WE.32.AD	BT40	72	32	100	AD	•
BT40.100.WE.06.AD	BT40	25	6	100	AD	•
BT40.100.WE.08.AD	BT40	28	8	100	AD	•
BT40.100.WE.10.AD	BT40	35	10	100	AD	•
BT40.100.WE.12.AD	BT40	42	12	100	AD	•
BT40.100.WE.14.AD	BT40	44	14	100	AD	•
BT40.100.WE.16.AD	BT40	48	16	100	AD	•
BT40.100.WE.18.AD	BT40	50	18	100	AD	•
BT40.100.WE.20.AD	BT40	52	20	100	AD	•

od průměru 25 se dvěma upínacími šrouby



Upínač Weldon pro upínací stopky



Upínač Weldon DIN 6359 pro upínací stopky DIN 1835-B

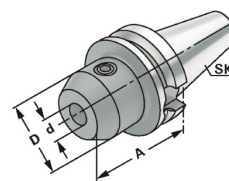

Název	Kužel	D	d	A		G 2,5 25.000 min ⁻¹
BT40.35.WE.16.ADB	BT40	45	16	35	AD/B	•
BT40.35.WE.20.ADB	BT40	45	20	35	AD/B	•
BT40.35.WE.25.ADB	BT40	45	25	35	AD/B	•
BT40.65.WE.32.ADB	BT40	62	32	65	AD/B	•
BT40.50.WE.06.ADB	BT40	25	6	50	AD/B	•
BT40.50.WE.08.ADB	BT40	28	8	50	AD/B	•
BT40.63.WE.10.ADB	BT40	35	10	63	AD/B	•
BT40.63.WE.12.ADB	BT40	42	12	63	AD/B	•
BT40.63.WE.14.ADB	BT40	44	14	63	AD/B	•
BT40.63.WE.16.ADB	BT40	48	16	63	AD/B	•
BT40.63.WE.18.ADB	BT40	50	18	63	AD/B	•
BT40.63.WE.20.ADB	BT40	52	20	63	AD/B	•
BT40.90.WE.25.ADB	BT40	65	25	90	AD/B	•
BT40.100.WE.32.ADB	BT40	72	32	100	AD/B	•
BT40.120.WE.40.ADB	BT40	80	40	120	AD/B	•
BT40.100.WE.06.ADB	BT40	25	6	100	AD/B	•
BT40.100.WE.08.ADB	BT40	28	8	100	AD/B	•
BT40.100.WE.10.ADB	BT40	35	10	100	AD/B	•
BT40.100.WE.12.ADB	BT40	42	12	100	AD/B	•
BT40.100.WE.14.ADB	BT40	44	14	100	AD/B	•
BT40.100.WE.16.ADB	BT40	48	16	100	AD/B	•
BT40.100.WE.18.ADB	BT40	50	18	100	AD/B	•
BT40.100.WE.20.ADB	BT40	52	20	100	AD/B	•
BT40.160.WE.06.ADB	BT40	25	6	160	AD/B	•
BT40.160.WE.08.ADB	BT40	28	8	160	AD/B	•
BT40.160.WE.10.ADB	BT40	35	10	160	AD/B	•
BT40.160.WE.12.ADB	BT40	42	12	160	AD/B	•
BT40.160.WE.14.ADB	BT40	44	14	160	AD/B	•
BT40.160.WE.16.ADB	BT40	48	16	160	AD/B	•
BT40.160.WE.18.ADB	BT40	50	18	160	AD/B	•
BT40.160.WE.20.ADB	BT40	52	20	160	AD/B	•
BT40.160.WE.25.ADB	BT40	65	25	160	AD/B	•
BT40.160.WE.32.ADB	BT40	72	32	160	AD/B	•
BT40.160.WE.40.ADB	BT40	80	40	160	AD/B	•

od průměru 25 se dvěma upínacími šrouby



Upínač Weldon pro upínací stopky



Upínač Weldon DIN 6359 pro upínací stopky DIN 1835-B

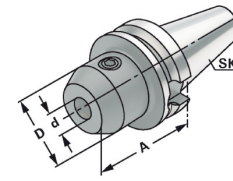

Katalogové číslo	Kužel	D	d	A		G 2,5 25.000 min ⁻¹
BT50.63.WE.06.ADB	BT50	25	6	63	AD/B	•
BT50.63.WE.08.ADB	BT50	28	8	63	AD/B	•
BT50.63.WE.10.ADB	BT50	35	10	63	AD/B	•
BT50.80.WE.12.ADB	BT50	42	12	80	AD/B	•
BT50.80.WE.14.ADB	BT50	44	14	80	AD/B	•
BT50.80.WE.16.ADB	BT50	48	16	80	AD/B	•
BT50.80.WE.18.ADB	BT50	50	18	80	AD/B	•
BT50.80.WE.20.ADB	BT50	52	20	80	AD/B	•
BT50.100.WE.25.ADB	BT50	65	25	100	AD/B	•
BT50.105.WE.32.ADB	BT50	72	32	105	AD/B	•
BT50.110.WE.40.ADB	BT50	80	40	110	AD/B	•
BT50.100.WE.06.ADB	BT50	25	6	100	AD/B	•
BT50.100.WE.08.ADB	BT50	28	8	100	AD/B	•
BT50.100.WE.10.ADB	BT50	35	10	100	AD/B	•
BT50.100.WE.12.ADB	BT50	42	12	100	AD/B	•
BT50.100.WE.14.ADB	BT50	44	14	100	AD/B	•
BT50.100.WE.16.ADB	BT50	48	16	100	AD/B	•
BT50.100.WE.18.ADB	BT50	50	18	100	AD/B	•
BT50.100.WE.20.ADB	BT50	52	20	100	AD/B	•
BT50.160.WE.06.ADB	BT50	25	6	160	AD/B	•
BT50.160.WE.08.ADB	BT50	28	8	160	AD/B	•
BT50.160.WE.10.ADB	BT50	35	10	160	AD/B	•
BT50.160.WE.12.ADB	BT50	42	12	160	AD/B	•
BT50.160.WE.14.ADB	BT50	44	14	160	AD/B	•
BT50.160.WE.16.ADB	BT50	48	16	160	AD/B	•
BT50.160.WE.18.ADB	BT50	50	18	160	AD/B	•
BT50.160.WE.20.ADB	BT50	52	20	160	AD/B	•
BT50.160.WE.25.ADB	BT50	65	25	160	AD/B	•
BT50.160.WE.32.ADB	BT50	72	32	160	AD/B	•
BT50.160.WE.40.ADB	BT50	80	40	160	AD/B	•
BT50.200.WE.06.ADB	BT50	25	6	200	AD/B	•
BT50.200.WE.08.ADB	BT50	28	8	200	AD/B	•
BT50.200.WE.10.ADB	BT50	35	10	200	AD/B	•
BT50.200.WE.12.ADB	BT50	42	12	200	AD/B	•
BT50.200.WE.14.ADB	BT50	44	14	200	AD/B	•
BT50.200.WE.16.ADB	BT50	48	16	200	AD/B	•
BT50.200.WE.18.ADB	BT50	50	18	200	AD/B	•
BT50.200.WE.20.ADB	BT50	52	20	200	AD/B	•
BT50.200.WE.25.ADB	BT50	65	25	200	AD/B	•
BT50.200.WE.32.ADB	BT50	72	32	200	AD/B	•
BT50.200.WE.40.ADB	BT50	80	40	200	AD/B	•
SK50.200.WE.40.ADB	SK50	40	80	200	AD/B	•

od průměru 25 se dvěma upínacími šrouby



Upínač Weldon s chladicími kanály pro upínací stopky



Upínač Weldon DIN 6359 pro upínací stopky DIN 1835-B

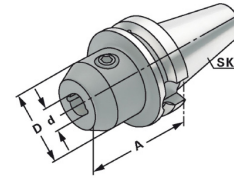

Katalogové číslo	Kužel	d	D	A		G 2,5 25.000 min ⁻¹
BT40.50.WK.06.ADB	BT40	6	25	63	AD/B	•
BT40.50.WK.08.ADB	BT40	8	28	63	AD/B	•
BT40.63.WK.10.ADB	BT40	10	35	63	AD/B	•
BT40.63.WK.12.ADB	BT40	12	42	80	AD/B	•
BT40.63.WK.14.ADB	BT40	14	44	80	AD/B	•
BT40.63.WK.16.ADB	BT40	16	48	80	AD/B	•
BT40.63.WK.18.ADB	BT40	18	50	80	AD/B	•
BT40.63.WK.20.ADB	BT40	20	52	80	AD/B	•
BT40.90.WK.25.ADB	BT40	25	65	100	AD/B	•
BT40.100.WK.32.ADB	BT40	32	72	105	AD/B	•
BT40.120.WK.40.ADB	BT40	40	80	110	AD/B	•
BT40.100.WK.06.ADB	BT40	6	25	100	AD/B	•
BT40.100.WK.08.ADB	BT40	8	28	100	AD/B	•
BT40.100.WK.10.ADB	BT40	10	35	100	AD/B	•
BT40.100.WK.12.ADB	BT40	12	42	100	AD/B	•
BT40.100.WK.14.ADB	BT40	14	44	100	AD/B	•
BT40.100.WK.16.ADB	BT40	16	48	100	AD/B	•
BT40.100.WK.18.ADB	BT40	18	50	100	AD/B	•
BT40.100.WK.20.ADB	BT40	20	52	100	AD/B	•
BT50.63.WK.06.ADB	BT50	6	25	63	AD/B	•
BT50.63.WK.08.ADB	BT50	8	28	63	AD/B	•
BT50.63.WK.10.ADB	BT50	10	35	63	AD/B	•
BT50.80.WK.12.ADB	BT50	12	42	80	AD/B	•
BT50.80.WK.14.ADB	BT50	14	44	80	AD/B	•
BT50.80.WK.16.ADB	BT50	16	48	80	AD/B	•
BT50.80.WK.18.ADB	BT50	18	50	80	AD/B	•
BT50.80.WK.20.ADB	BT50	20	52	80	AD/B	•
BT50.100.WK.25.ADB	BT50	25	65	100	AD/B	•
BT50.105.WK.32.ADB	BT50	32	72	105	AD/B	•
BT50.110.WK.40.ADB	BT50	40	80	110	AD/B	•

od průměr d = 25 se dvěma upínacími šrouby

d = 6 až 18 se dvěma chladicími kanály

d = 20 až 40 se čtyřmi chladicími kanály



Upínač Whistle Notch pro upínací stopky



Upínač Whistle Notch DIN 6359 pro upínací stopky DIN 1835-E

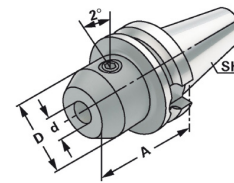

Katalogové číslo	Kužel	d	D	A		G 2,5 25.000 min ⁻¹
BT40.50.WN.06.ADB	BT40	6	25	50	AD/B	•
BT40.50.WN.08.ADB	BT40	8	28	50	AD/B	•
BT40.63.WN.10.ADB	BT40	10	35	63	AD/B	•
BT40.63.WN.12.ADB	BT40	12	42	63	AD/B	•
BT40.63.WN.14.ADB	BT40	14	44	63	AD/B	•
BT40.63.WN.16.ADB	BT40	16	48	63	AD/B	•
BT40.63.WN.18.ADB	BT40	18	50	63	AD/B	•
BT40.63.WN.20.ADB	BT40	20	52	63	AD/B	•
BT40.90.WN.25.ADB	BT40	25	65	90	AD/B	•
BT40.100.WN.32.ADB	BT40	32	72	100	AD/B	•
BT40.120.WN.40.ADB	BT40	40	80	120	AD/B	•
BT50.63.WN.06.ADB	BT50	6	25	63	AD/B	•
BT50.63.WN.08.ADB	BT50	8	28	63	AD/B	•
BT50.63.WN.10.ADB	BT50	10	35	63	AD/B	•
BT50.80.WN.12.ADB	BT50	12	42	80	AD/B	•
BT50.80.WN.14.ADB	BT50	14	44	80	AD/B	•
BT50.80.WN.16.ADB	BT50	16	48	80	AD/B	•
BT50.80.WN.18.ADB	BT50	18	50	80	AD/B	•
BT50.80.WN.20.ADB	BT50	20	52	80	AD/B	•
BT50.100.WN.25.ADB	BT50	25	65	100	AD/B	•
BT50.105.WN.32.ADB	BT50	32	72	105	AD/B	•
BT50.110.WN.40.ADB	BT50	40	80	110	AD/B	•

od průměr d = 25 se dvěma upínacími šrouby



Upínač pro nástroje s morse stopkou



DIN 228-1 Form B

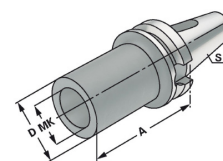

Katalogové číslo	Kužel	MK	D	A		G 6,3 15.000 min ⁻¹
BT40.50.MK.1.ADB	BT40	1	25	50	AD/B	•
BT40.50.MK.2.ADB	BT40	2	32	50	AD/B	•
BT40.70.MK.3.ADB	BT40	3	40	70	AD/B	•
BT40.95.MK.4.ADB	BT40	4	48	95	AD/B	•
BT50.45.MK.1.ADB	BT50	1	25	45	AD/B	•
BT50.60.MK.2.ADB	BT50	2	32	60	AD/B	•
BT50.65.MK.3.ADB	BT50	3	40	65	AD/B	•
BT50.95.MK.4.ADB	BT50	4	48	95	AD/B	•
BT50.105.MK.5.ADB	BT50	5	63	105	AD/B	•

Upínač pro nástroje s morse stopkou a závitem dle DIN228-A

DIN 228-1 Form A

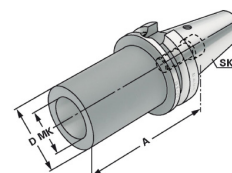

Katalogové číslo	Kužel	MK	D	A		G 6,3 15.000 min ⁻¹
BT40.50.MKS.1	BT40	1	25	50		•
BT40.50.MKS.2	BT40	2	32	50		•
BT40.70.MKS.3	BT40	3	40	70		•
BT40.95.MKS.4	BT40	4	48	95		•
BT40.110.MKS.4.D*	BT40	4	63	110		•
BT50.45.MKS.1	BT50	1	25	45		•
BT50.60.MKS.2	BT50	2	32	60		•
BT50.65.MKS.3	BT50	3	40	65		•
BT50.70.MKS.4	BT50	4	48	70		•
BT50.85.MKS.4.D*	BT50	4	63	85		•
BT50.100.MKS.5	BT50	5	63	100		•
BT50.118.MKS.5.D*	BT50	5	78	118		•

* s upínací drážkou dle DIN 2201



Upínač pro nástrčné frézy



DIN 6357

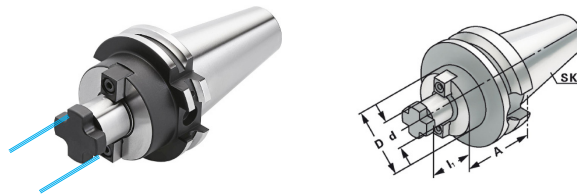

Katalogové číslo	Kužel	d	D	A	l ₁		G 2,5 25.000 min ⁻¹
BT40.40.N.16.AD	BT40	16	38	40	17	AD	•
BT40.40.N.22.AD	BT40	22	48	40	19	AD	•
BT40.40.N.27.AD	BT40	27	58	40	21	AD	•
BT40.50.N.32.AD	BT40	32	78	50	24	AD	•
BT40.50.N.40.AD	BT40	40	88	50	27	AD	•
BT40.40.N.16.ADB	BT40	16	38	40	17	AD/B	•
BT40.40.N.22.ADB	BT40	22	48	40	19	AD/B	•
BT40.40.N.27.ADB	BT40	27	58	40	21	AD/B	•
BT40.50.N.32.ADB	BT40	32	78	50	24	AD/B	•
BT40.50.N.40.ADB	BT40	40	88	50	27	AD/B	•
BT40.100.N.16.ADB	BT40	16	38	100	17	AD/B	•
BT40.100.N.22.ADB	BT40	22	48	100	19	AD/B	•
BT40.100.N.27.ADB	BT40	27	58	100	21	AD/B	•
BT40.100.N.32.ADB	BT40	32	78	100	24	AD/B	•
BT40.100.N.40.ADB	BT40	40	88	100	27	AD/B	•
BT40.160.N.16.ADB	BT40	16	38	160	17	AD/B	•
BT40.160.N.22.ADB	BT40	22	48	160	19	AD/B	•
BT40.160.N.27.ADB	BT40	27	58	160	21	AD/B	•
BT40.160.N.32.ADB	BT40	32	78	160	24	AD/B	•
BT40.160.N.40.ADB	BT40	40	88	160	27	AD/B	•
BT50.40.N.22.ADB	BT50	22	48	40	19	AD/B	•
BT50.40.N.27.ADB	BT50	27	58	40	21	AD/B	•
BT50.50.N.32.ADB	BT50	32	78	50	24	AD/B	•
BT50.50.N.40.ADB	BT50	40	88	50	27	AD/B	•
BT50.80.N.60.ADB	BT50	60	129	80	40	AD/B	•
BT50.100.N.22.ADB	BT50	22	48	100	19	AD/B	•
BT50.100.N.27.ADB	BT50	27	58	100	21	AD/B	•
BT50.100.N.32.ADB	BT50	32	78	100	24	AD/B	•
BT50.100.N.40.ADB	BT50	40	88	100	27	AD/B	•
BT50.160.N.22.ADB	BT50	22	48	160	19	AD/B	•
BT50.160.N.27.ADB	BT50	27	58	160	21	AD/B	•
BT50.160.N.32.ADB	BT50	32	78	160	24	AD/B	•
BT50.160.N.40.ADB	BT50	40	88	160	27	AD/B	•

d = 40/d = 60: pro velké průměry fréz se čtyřmi závitovými otvory dle DIN 2079

dobrávka: s upínacím šroubem s křížovou hlavou a s upínacím šroubem s válcovou hlavou dle DIN 912 pro frézy s vnitřním chlazením

pro d = 60 pouze se čtyřmi upínacími šrouby dle DIN 912

S výstupními otvory chlazení na čele upínače



Upínač pro nástrčné frézy - kombi



DIN 6358

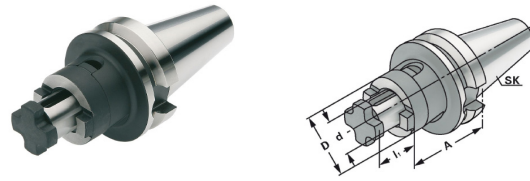

Katalogové číslo	Kužel	d	D	A	l ₁		G 6,3 15.000 min ⁻¹
BT40.55.NK.16.ADB	BT40	16	32	55	17	AD/B	•
BT40.55.NK.22.ADB	BT40	22	40	55	19	AD/B	•
BT40.55.NK.27.ADB	BT40	27	48	55	21	AD/B	•
BT40.60.NK.32.ADB	BT40	32	58	60	24	AD/B	•
BT40.60.NK.40.ADB	BT40	40	70	60	27	AD/B	•
BT40.100.NK.16.ADB	BT40	16	32	100	17	AD/B	•
BT40.100.NK.22.ADB	BT40	22	40	100	19	AD/B	•
BT40.100.NK.27.ADB	BT40	27	48	100	21	AD/B	•
BT40.100.NK.32.ADB	BT40	32	58	100	24	AD/B	•
BT40.100.NK.40.ADB	BT40	40	70	100	27	AD/B	•
BT40.160.NK.16.ADB	BT40	16	32	160	17	AD/B	•
BT40.160.NK.22.ADB	BT40	22	40	160	19	AD/B	•
BT40.160.NK.27.ADB	BT40	27	48	160	21	AD/B	•
BT40.160.NK.32.ADB	BT40	32	58	160	24	AD/B	•
BT40.160.NK.40.ADB	BT40	40	70	160	27	AD/B	•
BT50.70.NK.16.ADB	BT50	16	32	70	17	AD/B	•
BT50.70.NK.22.ADB	BT50	22	40	70	19	AD/B	•
BT50.70.NK.27.ADB	BT50	27	48	70	21	AD/B	•
BT50.70.NK.32.ADB	BT50	32	58	70	24	AD/B	•
BT50.70.NK.40.ADB	BT50	40	70	70	27	AD/B	•
BT50.160.NK.16.ADB	BT50	16	32	160	17	AD/B	•
BT50.160.NK.22.ADB	BT50	22	40	160	19	AD/B	•
BT50.160.NK.27.ADB	BT50	27	48	160	21	AD/B	•
BT50.160.NK.32.ADB	BT50	32	58	160	24	AD/B	•
BT50.160.NK.40.ADB	BT50	40	70	160	27	AD/B	•

dodávka: s upínacím šroubem, unašecím kroužkem a perem



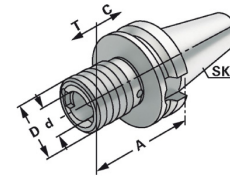

Závitořezná hlava s délkovou kompenzací

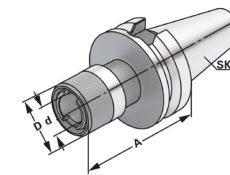

Katalogové číslo	Kužel	Rozsah	D	d	A	T	C	Upínač závítníku
BT40.314.Z.1.DK	BT40	M3 - M14	36	19	65	7	7	UZB1/UZS1
BT40.522.Z.2.DK	BT40	M5 - M22	53	31	93	12	12	UZB2/UZS2
BT40.1436.Z.3.DK	BT40	M14 - M36	78	48	166	17,5	17,5	UZB3/UZS3
BT50.314.Z.1.DK	BT50	M3 - M14	36	19	100	7	7	UZB1/UZS1
BT50.522.Z.2.DK	BT50	M5 - M22	53	31	10	12	12	UZB2/UZS2
BT50.1436.Z.3.DK	BT50	M14 - M36	78	48	142	17,5	17,5	UZB3/UZS3

Závitořezná hlava bez délkové kompenzace





Katalogové číslo	Kužel	Rozsah	D	d	A	Upínač závítníku	
BT40.314.Z.1.BK	BT40	M3 - M14	38	19	72	UZB1/UZS1	AD
BT40.522.Z.2.BK	BT40	M5 - M22	54	31	93	UZB2/UZS2	AD
BT40.1436.Z.3.BK	BT40	M14 - M36	78	48	130	UZB3/UZS3	AD
BT50.314.Z.1.BK	BT50	M3 - M14	38	19	80	UZB1/UZS1	AD
BT50.522.Z.2.BK	BT50	M5 - M22	54	31	95	UZB2/UZS2	AD
BT50.1436.Z.3.BK	BT50	M14 - M36	78	48	142	UZB3/UZS3	AD

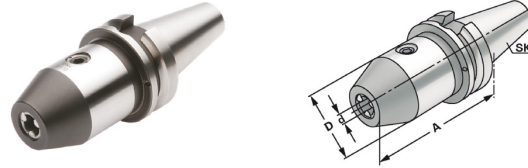

Vrtací hlavička



Katalogové číslo	Kužel	Rozsah d	D	A			G 6,3 15.000 min ⁻¹
BT40.78.V.8.AD	BT40	0 - 8	36	78	AD	VT4	•
BT40.98.V.13.AD	BT40	1 - 13	50	98	AD	VT6	•
BT40.103.V.16.AD	BT40	2,5 - 16	50	103	AD	VT6	•
BT50.108.V.13.AD	BT50	1 - 13	50	111	AD	VT6	•
BT50.110.V.16.AD	BT50	2,5 - 16	50	113	AD	VT6	•

dodávka: bez montážního klíče

Upínač - redukce pro vrtací hlavičky

DIN 238

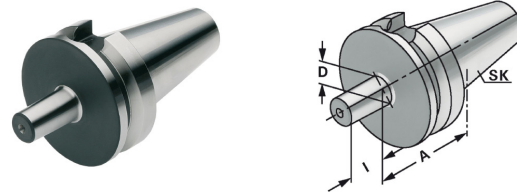

Katalogové číslo	Kužel	D	A	l	G 6,3 15.000 min ⁻¹
BT40.25.B12	BT40	B12	25	18,5	•
BT40.25.B16	BT40	B16	25	24	•
BT40.32.B18	BT40	B18	32	32	•
BT50.32.B16	BT50	B16	32	24	•
BT50.32.B18	BT50	B18	32	32	•



Upínač pro frézy se závitem

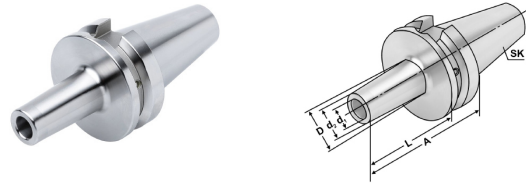

Katalogové číslo	Kužel	M	D	d ₂	d ₁	L	A		G 2,5 25.000 min ⁻¹
BT40.52.M.06.ADB	BT40	6	13	10	6,5	25	52	AD/B	•
BT40.77.M.06.ADB	BT40	6	20	10	6,5	50	77	AD/B	•
BT40.102.M.06.ADB	BT40	6	23	10	6,5	75	102	AD/B	•
BT40.52.M.08.ADB	BT40	8	15	13	8,5	25	52	AD/B	•
BT40.77.M.08.ADB	BT40	8	23	13	8,5	50	77	AD/B	•
BT40.102.M.08.ADB	BT40	8	23	13	8,5	75	102	AD/B	•
BT40.127.M.08.ADB	BT40	8	25	13	8,5	100	127	AD/B	•
BT40.52.M.10.ADB	BT40	10	20	18	10,5	25	52	AD/B	•
BT40.77.M.10.ADB	BT40	10	23	18	10,5	50	77	AD/B	•
BT40.102.M.10.ADB	BT40	10	28	18	10,5	75	102	AD/B	•
BT40.127.M.10.ADB	BT40	10	32	18	10,5	100	127	AD/B	•
BT40.52.M.12.ADB	BT40	12	24	21	12,5	25	52	AD/B	•
BT40.77.M.12.ADB	BT40	12	24	21	12,5	50	77	AD/B	•
BT40.102.M.12.ADB	BT40	12	31	21	12,5	75	102	AD/B	•
BT40.127.M.12.ADB	BT40	12	33	21	12,5	100	127	AD/B	•
BT40.152.M.12.ADB	BT40	12	36	21	12,5	125	152	AD/B	•
BT40.52.M.16.ADB	BT40	16	29	29	17	25	52	AD/B	•
BT40.77.M.16.ADB	BT40	16	34	29	17	50	77	AD/B	•
BT40.102.M.16.ADB	BT40	16	34	29	17	75	102	AD/B	•
BT40.127.M.16.ADB	BT40	16	36	29	17	100	127	AD/B	•
BT40.152.M.16.ADB	BT40	16	40	29	17	125	152	AD/B	•
BT40.177.M.16.ADB	BT40	16	42	29	17	150	177	AD/B	•
BT50.88.M.08.ADB	BT50	8	23	13	8,5	50	88	AD/B	•
BT50.138.M.08.ADB	BT50	8	25	13	8,5	100	138	AD/B	•
BT50.188.M.08.ADB	BT50	8	30	13	8,5	150	188	AD/B	•
BT50.88.M.10.ADB	BT50	10	23	18	10,5	50	88	AD/B	•
BT50.138.M.10.ADB	BT50	10	32	18	10,5	100	138	AD/B	•
BT50.188.M.10.ADB	BT50	10	37	18	10,5	150	188	AD/B	•
BT50.88.M.12.ADB	BT50	12	24	21	12,5	50	88	AD/B	•
BT50.138.M.12.ADB	BT50	12	33	21	12,5	100	138	AD/B	•
BT50.188.M.12.ADB	BT50	12	40	21	12,5	150	188	AD/B	•
BT50.88.M.16.ADB	BT50	16	34	29	17	50	88	AD/B	•
BT50.113.M.16.ADB	BT50	16	36	29	17	75	113	AD/B	•
BT50.138.M.16.ADB	BT50	16	36	29	17	100	138	AD/B	•
BT50.188.M.16.ADB	BT50	16	43	29	17	150	188	AD/B	•

Doporučené utahovací momenty

M6	10 Nm
M8	25 Nm
M10	40 Nm
M12	50 Nm
M16	60 Nm





Hydro upínač

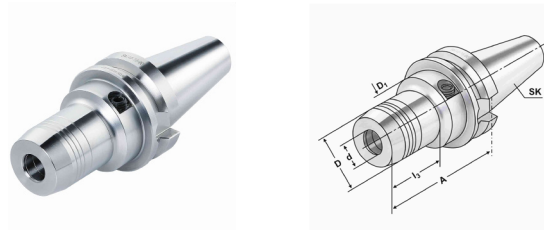

pro válcové upínací stopky DIN 1835 typ A+B+E a DIN 6535 typ HB+HE

(průměry nad 20 mm pouze s redukčním pouzdem)



Katalogové číslo	Kužel	d	D	D ₁	l ₁	l ₂	l ₃	A		G 2,5 25.000 min ⁻¹
BT40.90.H.06.ADB	BT40	6	26	50	37	10	43	90	AD/B	•
BT40.90.H.08.ADB	BT40	8	28	50	37	10	43,5	90	AD/B	•
BT40.90.H.10.ADB	BT40	10	30	50	42	10	44	90	AD/B	•
BT40.90.H.12.ADB	BT40	12	32	50	47	10	44,5	90	AD/B	•
BT40.90.H.14.ADB	BT40	14	34	50	47	10	47,5	90	AD/B	•
BT40.90.H.16.ADB	BT40	16	38	50	52	10	47,5	90	AD/B	•
BT40.90.H.18.ADB	BT40	18	40	50	52	10	47,5	90	AD/B	•
BT40.90.H.20.ADB	BT40	20	42	50	52	10	47,5	90	AD/B	•
BT40.90.H.25.ADB	BT40	25	50	50	58	10	63	90	AD/B	•
BT40.110.H.32.ADB	BT40	32	60	60	62	10	83	110	AD/B	•
BT40.150.H.06.ADB	BT40	6	26	50	37	10	102	150	AD/B	•
BT40.150.H.08.ADB	BT40	8	28	50	37	10	103	150	AD/B	•
BT40.150.H.10.ADB	BT40	10	30	50	42	10	104	150	AD/B	•
BT40.150.H.12.ADB	BT40	12	32	50	47	10	105	150	AD/B	•
BT40.150.H.14.ADB	BT40	14	34	50	47	10	105	150	AD/B	•
BT40.150.H.16.ADB	BT40	16	38	50	52	10	106	150	AD/B	•
BT40.150.H.18.ADB	BT40	18	40	50	52	10	107	150	AD/B	•
BT40.150.H.20.ADB	BT40	20	42	50	52	10	108	150	AD/B	•
BT40.150.H.25.ADB	BT40	25	50	50	58	10	123	150	AD/B	•
BT40.150.H.32.ADB	BT40	32	60	60	62	10	123	150	AD/B	•
BT40.200.H.06.ADB	BT40	6	26	50	37	10	152	200	AD/B	•
BT40.200.H.08.ADB	BT40	8	28	50	37	10	153	200	AD/B	•
BT40.200.H.10.ADB	BT40	10	30	50	42	10	154	200	AD/B	•
BT40.200.H.12.ADB	BT40	12	32	50	47	10	155	200	AD/B	•
BT40.200.H.14.ADB	BT40	14	34	50	47	10	155	200	AD/B	•
BT40.200.H.16.ADB	BT40	16	38	50	52	10	156	200	AD/B	•
BT40.200.H.18.ADB	BT40	18	40	50	52	10	157	200	AD/B	•
BT40.200.H.20.ADB	BT40	20	42	50	52	10	158	200	AD/B	•
BT40.200.H.25.ADB	BT40	25	50	50	58	10	173	200	AD/B	•
BT40.200.H.32.ADB	BT40	32	60	50	62	10	173	200	AD/B	•
BT50110.H.06.ADB	BT50	6	26	80	37	10	43	110	AD/B	•
BT50.110.H.08.ADB	BT50	8	28	80	37	10	43,5	110	AD/B	•
BT50.110.H.10.ADB	BT50	10	30	80	42	10	44	110	AD/B	•
BT50.110.H.12.ADB	BT50	12	32	80	47	10	42	110	AD/B	•
BT50.110.H.14.ADB	BT50	14	34	80	47	10	42	110	AD/B	•
BT50.110.H.16.ADB	BT50	16	38	80	52	10	45	110	AD/B	•
BT50.110.H.18.ADB	BT50	18	40	80	52	10	47,5	110	AD/B	•
BT50.110.H.20.ADB	BT50	20	42	80	52	10	47,5	110	AD/B	•
BT50.110.H.25.ADB	BT50	25	50	80	58	10	47,5	110	AD/B	•
BT50.110.H.32.ADB	BT50	32	60	80	62	10	47,5	110	AD/B	•

l₁ = maximální upínací délka

l₂ = maximální délkové nastavení

dodávka: bez montážního klíče



Upínač tepelný 4,5°

pro upínání nástrojů se stopkou TK a HSS

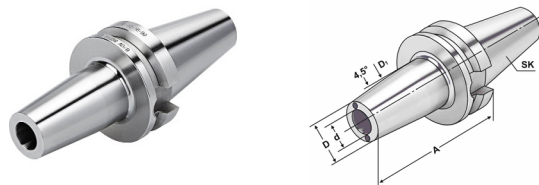

Katalogové číslo	Kužel	d	D	D ₁	l ₁	l ₂	A		G 2,5 25.000 min ⁻¹
BT40.80.T4.03.ADB	BT40	3	11	15	-	-	80	AD/B	•
BT40.80.T4.04.ADB	BT40	4	14	22	-	-	80	AD/B	•
BT40.80.T4.05.ADB	BT40	5	16	22	-	-	80	AD/B	•
BT40.90.T4.06.ADB	BT40	6	21	27	36	10	90	AD/B	•
BT40.120.T4.06.ADB	BT40	6	21	27	36	10	120	AD/B	•
BT40.160.T4.06.ADB	BT40	6	21	27	36	10	160	AD/B	•
BT40.90.T4.08.ADB	BT40	8	21	27	36	10	90	AD/B	•
BT40.120.T4.08.ADB	BT40	8	21	27	36	10	120	AD/B	•
BT40.160.T4.08.ADB	BT40	8	21	27	36	10	160	AD/B	•
BT40.90.T4.10.ADB	BT40	10	24	32	41	10	90	AD/B	•
BT40.120.T4.10.ADB	BT40	10	24	32	41	10	120	AD/B	•
BT40.160.T4.10.ADB	BT40	10	24	32	42	10	160	AD/B	•
BT40.90.T4.12.ADB	BT40	12	24	32	46	10	90	AD/B	•
BT40.120.T4.12.ADB	BT40	12	24	32	46	10	120	AD/B	•
BT40.160.T4.12.ADB	BT40	12	24	32	46	10	160	AD/B	•
BT40.90.T4.14.ADB	BT40	14	27	34	46	10	90	AD/B	•
BT40.120.T4.14.ADB	BT40	14	27	34	46	10	120	AD/B	•
BT40.160.T4.14.ADB	BT40	14	27	34	46	10	160	AD/B	•
BT40.90.T4.16.ADB	BT40	16	27	34	49	10	90	AD/B	•
BT40.120.T4.16.ADB	BT40	16	27	34	49	10	120	AD/B	•
BT40.160.T4.16.ADB	BT40	16	27	34	49	10	160	AD/B	•
BT40.90.T4.18.ADB	BT40	18	33	42	49	10	90	AD/B	•
BT40.120.T4.18.ADB	BT40	18	33	42	49	10	120	AD/B	•
BT40.160.T4.18.ADB	BT40	18	33	42	49	10	160	AD/B	•
BT40.90.T4.20.ADB	BT40	20	33	42	51	10	90	AD/B	•
BT40.120.T4.20.ADB	BT40	20	33	42	51	10	120	AD/B	•
BT40.160.T4.20.ADB	BT40	20	33	42	51	10	160	AD/B	•
BT40.100.T4.25.ADB	BT40	25	44	53	57	10	100	AD/B	•
BT40.120.T4.25.ADB	BT40	25	44	53	57	10	120	AD/B	•
BT40.160.T4.25.ADB	BT40	25	44	53	57	10	160	AD/B	•
BT40.100.T4.32.ADB	BT40	32	44	53	61	10	100	AD/B	•
BT40.160.T4.32.ADB	BT40	32	44	62	61	10	160	AD/B	•

l₁ = maximální upínací délka

l₂ = maximální délkové nastavení

pro průměry stopek 3, 4 a 5 mm pouze pro karbidové nástroje
 pro průměry stopek 3, 4, a mm s tolerancí h4 a průměry stopek 6 až 32 s tolerancí h6
 vhodné pro přístroje, které používají ohřev indukční, kontaktní a teplým vzduchem



Upínač tepelný 4,5°

pro upínání nástrojů se stopkou TK a HSS

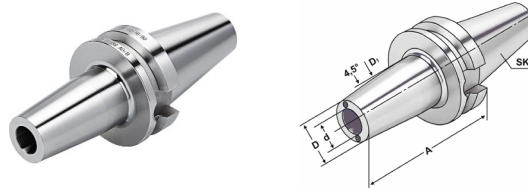

Katalogové číslo	Kužel	d	D	D ₁	l ₁	l ₂	A		G 2,5 25.000 min ⁻¹
BT50.100.T4.04.ADB	BT50	4	15	20	-	-	100	AD/B	•
BT50.100.T4.05.ADB	BT50	5	15	20	-	-	100	AD/B	•
BT50.100.T4.06.ADB	BT50	6	21	27	36	10	100	AD/B	•
BT50.120.T4.06.ADB	BT50	6	21	27	36	10	120	AD/B	•
BT50.160.T4.06.ADB	BT50	6	21	27	36	10	160	AD/B	•
BT50.100.T4.08.ADB	BT50	8	21	27	36	10	100	AD/B	•
BT50.120.T4.08.ADB	BT50	8	21	27	36	10	120	AD/B	•
BT50.160.T4.08.ADB	BT50	8	21	27	36	10	160	AD/B	•
BT50.200.T4.08.ADB	BT50	8	21	27	36	10	200	AD/B	•
BT50.100.T4.10.ADB	BT50	10	24	32	41	10	100	AD/B	•
BT50.120.T4.10.ADB	BT50	10	24	32	41	10	120	AD/B	•
BT50.160.T4.10.ADB	BT50	10	24	32	41	10	160	AD/B	•
BT50.200.T4.10.ADB	BT50	10	24	32	41	10	200	AD/B	•
BT50.100.T4.12.ADB	BT50	12	24	32	46	10	100	AD/B	•
BT50.120.T4.12.ADB	BT50	12	24	32	46	10	120	AD/B	•
BT50.160.T4.12.ADB	BT50	12	24	32	46	10	160	AD/B	•
BT50.200.T4.12.ADB	BT50	12	24	32	46	10	200	AD/B	•
BT50.100.T4.14.ADB	BT50	14	27	34	46	10	100	AD/B	•
BT50.120.T4.14.ADB	BT50	14	27	34	46	10	120	AD/B	•
BT50.160.T4.14.ADB	BT50	14	27	34	46	10	160	AD/B	•
BT50.200.T4.14.ADB	BT50	14	27	34	46	10	200	AD/B	•
BT50.100.T4.16.ADB	BT50	16	27	34	49	10	100	AD/B	•
BT50.120.T4.16.ADB	BT50	16	27	34	49	10	120	AD/B	•
BT50.160.T4.16.ADB	BT50	16	27	34	49	10	160	AD/B	•
BT50.200.T4.16.ADB	BT50	16	27	34	49	10	200	AD/B	•
BT50.110.T4.18.ADB	BT50	18	33	42	49	10	110	AD/B	•
BT50.120.T4.18.ADB	BT50	18	33	42	49	10	120	AD/B	•
BT50.160.T4.18.ADB	BT50	18	33	42	49	10	160	AD/B	•
BT50.200.T4.18.ADB	BT50	18	33	42	49	10	200	AD/B	•
BT50.110.T4.20.ADB	BT50	20	33	42	51	10	110	AD/B	•
BT50.120.T4.20.ADB	BT50	20	33	42	51	10	120	AD/B	•
BT50.160.T4.20.ADB	BT50	20	33	42	51	10	160	AD/B	•
BT50.200.T4.20.ADB	BT50	20	33	42	51	10	200	AD/B	•
BT50.120.T4.25.ADB	BT50	25	44	53	57	10	120	AD/B	•
BT50.160.T4.25.ADB	BT50	25	44	53	57	10	160	AD/B	•
BT50.200.T4.25.ADB	BT50	25	44	53	57	10	200	AD/B	•
BT50.120.T4.32.ADB	BT50	32	44	53	61	10	120	AD/B	•
BT50.160.T4.32.ADB	BT50	32	44	53	61	10	160	AD/B	•

l₁ = maximální upínací délka

l₂ = maximální délkové nastavení

pro průměry stopek 3, 4 a 5 mm pouze pro karbidové nástroje
 pro průměry stopek 3, 4, a mm s tolerancí h4 a průměry stopek 6 až 32 s tolerancí h6
 vhodné pro přístroje, které používají ohřev indukční, kontaktní a teplým vzduchem



Upínač tepelný 4,5° s chladícími kanály



pro upínání nástrojů se stopkou TK a HSS

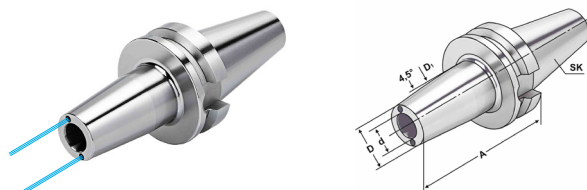

Katalogové číslo	Kužel	d	D	D ₁	l ₁	l ₂	A		G 2,5 25.000 min ⁻¹
BT40.90.TK4.06.ADB	BT40	6	21	27	36	10	90	AD/B	•
BT40.90.TK4.08.ADB	BT40	8	21	27	36	10	90	AD/B	•
BT40.90.TK4.10.ADB	BT40	10	24	32	41	10	90	AD/B	•
BT40.90.TK4.12.ADB	BT40	12	24	32	46	10	90	AD/B	•
BT40.90.TK4.14.ADB	BT40	14	27	34	46	10	90	AD/B	•
BT40.90.TK4.16.ADB	BT40	16	27	34	49	10	90	AD/B	•
BT40.90.TK4.18.ADB	BT40	18	33	42	49	10	90	AD/B	•
BT40.90.TK4.20.ADB	BT40	20	33	42	51	10	90	AD/B	•
BT50.100.TK4.06.ADB	BT50	6	21	27	36	10	100	AD/B	•
BT50.100.TK4.08.ADB	BT50	8	21	27	36	10	100	AD/B	•
BT50.100.TK4.10.ADB	BT50	10	24	32	41	10	100	AD/B	•
BT50.100.TK4.12.ADB	BT50	12	24	32	46	10	100	AD/B	•
BT50.100.TK4.14.ADB	BT50	14	27	34	46	10	100	AD/B	•
BT50.100.TK4.16.ADB	BT50	16	27	34	49	10	100	AD/B	•
BT50.110.TK4.18.ADB	BT50	18	33	42	49	10	110	AD/B	•
BT50.110.TK4.20.ADB	BT50	20	33	42	51	10	110	AD/B	•

l₁ = maximální upínací délka

pro průměry stopek 6 až 25 s tolerancí h6

vhodné pro přístroje, které používají ohřev indukční, kontaktní a teplým vzduchem

l₂ = maximální délkové nastavení



Upínač tepelný 3°

pro upínání nástrojů se stopkou TK a HSS



Katalogové číslo	Kužel	d	D	D ₁	l ₁	l ₂	A		G 2,5 25.000 min ⁻¹
BT40.90.T3.03.ADB	BT40	3	9	15,5	-	-	90	AD/B	•
BT40.120.T3.03.ADB	BT40	3	9	19,5	-	-	120	AD/B	•
BT40.90.T3.04.ADB	BT40	4	10	16,5	-	-	90	AD/B	•
BT40.120.T3.04.ADB	BT40	4	10	20,5	-	-	120	AD/B	•
BT40.90.T3.05.ADB	BT40	5	11	17,5	-	-	90	AD/B	•
BT40.120.T3.05.ADB	BT40	5	11	21,5	-	-	120	AD/B	•
BT40.90.T3.06.ADB	BT40	6	12	18,5	36	10	90	AD/B	•
BT40.120.T3.06.ADB	BT40	6	12	22,5	36	10	120	AD/B	•
BT40.160.T3.06.ADB	BT40	6	12	26,5	36	10	160	AD/B	•
BT40.90.T3.08.ADB	BT40	8	14	20,5	36	10	90	AD/B	•
BT40.120.T3.08.ADB	BT40	8	14	24,5	36	10	120	AD/B	•
BT40.160.T3.08.ADB	BT40	8	14	28,5	36	10	160	AD/B	•
BT40.90.T3.10.ADB	BT40	10	16	22,5	41	10	90	AD/B	•
BT40.120.T3.10.ADB	BT40	10	16	26,5	41	10	120	AD/B	•
BT40.160.T3.10.ADB	BT40	10	16	30,5	41	10	160	AD/B	•
BT40.90.T3.12.ADB	BT40	12	18	24,5	46	10	90	AD/B	•
BT40.120.T3.12.ADB	BT40	12	18	28,5	46	10	120	AD/B	•
BT40.160.T3.12.ADB	BT40	12	18	32,5	46	10	160	AD/B	•

l₁ = maximální upínací délka

l₂ = maximální délkové nastavení

pro průměry stopek 3, 4 a 5 mm pouze pro karbidové nástroje
 pro průměry stopek 3,4, a mm s tolerancí h4 a průměry stopek 6 až 32 s tolerancí h6
 vhodné pro přístroje, které používají ohřev indukční, kontaktní a teplým vzduchem



Upínač - polotovar



Katalogové číslo	Kužel	D	A
BT40.250.P.63	BT40	63	250
BT50.315.P.97	BT50	97	315

Kužel a příruba kalena a broušena. Těleso měkké pro další opracování.

Kontrolní trn

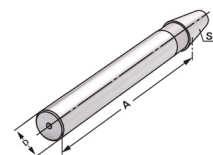

Katalogové číslo	Kužel	D	A	Max. odchylka soustřednosti
BT40.300.K.40	BT40	40	300	0,003
BT50.300.K.50	BT50	50	300	0,003

dodávka: s kontrolním protokolem

Dřevěná kazeta pro kontrolní trn



Katalogové číslo	Kužel	Rozměr
Kazeta pro kontrolní trn	BT40 / BT50	460x130x115



Redukční pouzdro BT / SK

pro DIN 69871, JIS B 6339, DIN 2080

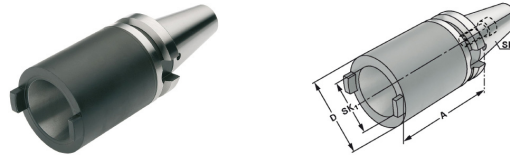

Katalogové číslo	Kužel	Kužel	D	A	G 6,3 15.000 min ⁻¹
BT40.50.R.30	BT40	SK30	63	60	•
BT40.100.R.40	BT40	SK40	63	100	•
BT50.70.R.40	BT50	SK40	70	70	•
BT50.120.R.50	BT50	SK50	97	120	•

dodávka s namontovaným upínacím šroubem pro krátký upínací kužel
včetně upínacího šroubu pro DIN 2080



Upínací kužely

DUAL KONTAKT JIS B 6339 (MAS 403 BT)

Upínací kužely jsou předvyváženy.

G 6.3 15.000 min⁻¹, G 2,5 25.000 min⁻¹
(G 2.5 vyšší vyvážení za příplatek)

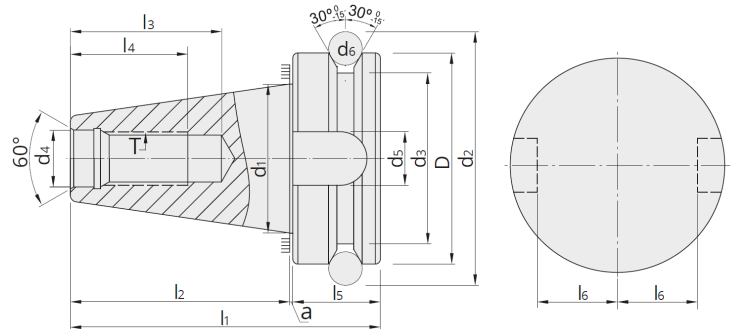

Kužel	D H8	d1	d2	d3	d4 H8	d5 H12	d6	d9 H12	a ± 0,005	l1	l2 ± 0,2	l3 min	l4 min	l5	l6 0 - 0,2	e1 ± 0,1	e2 max	T
BT30	46	31,7	56,14	38	12,5	16,1	8	-	1	70,4	48,4	34	24	21	16	-	-	M12
BT40	63	44,45	75,679	53	17,0	16,1	10	4	1	92,4	65,4	43	30	26	22,6	27	5	M16
BT50	100	69,85	119,02	85	25,0	25,7	15	6	1,5	139,8	101,8	62	45	36,5	35,4	42	7	M24

S vnitřním chlazením přes límec – typ AD/B

Dodávka se šrouby bez hlavy v zavřené pozici.

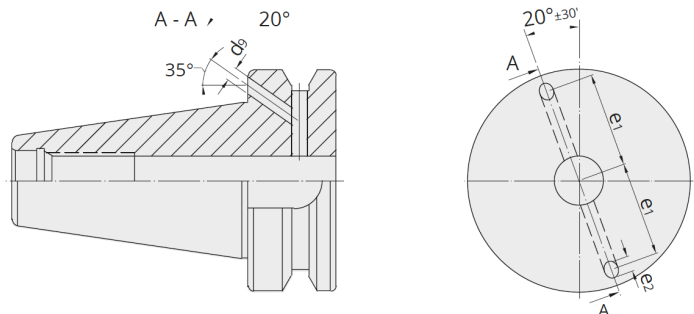

materiál: legovaná ocel cementovaná do hl. 0.8 ± 0.2 mm, kalená na 60 ± 2 HRC
s pevností v jádru min. 950 N/mm²
černěno a přesně broušeno

provedení AD/B: dodáváno v typu AD, typ B se šrouby bez hlavy v zavřené pozici

přesnost: kvalita kuželu < AT3 dle normy DIN 7187 a DIN 2080

NA-U-DUAL-BT-1-001-03/23



NA-U-DUAL-BT-1-001-03/23



NA-U-DUAL-BT-2-001-03/23



NA-U-DUAL-BT-2-002-03/23



NA-U-DUAL-BT-4-001-03/23



NA-U-DUAL-BT-5-001-03/23



NA-U-DUAL-BT-5-001-03/23



NA-U-DUAL-BT-6-001-03/23



NA-U-DUAL-BT-6-001-03/23



NA-U-DUAL-BT-6-002-03/23



NA-U-DUAL-BT-7-001-03/23



NA-U-DUAL-BT-8-001-03/23



NA-U-DUAL-BT-9-001-03/23



NA-U-DUAL-BT-9-001-03/23



NA-U-DUAL-BT-9-001-03/23



NA-U-DUAL-BT-9-002-03/23



Kleštinový upínač pro kleštiny ER

DIN 6499 (ISO 15488)



Název	Kužel	Rozsah	D	A			G 2,5 25.000 min ⁻¹
BT30DK.70.ER.16.AD	BT30DK	1 – 10 (ER 16)	32	70	AD	ER16K	•
BT30DK.70.ER.25.AD	BT30DK	2 – 16 (ER 25)	42	70	AD	ER25K	•
BT30DK.70.ER.32.AD	BT30DK	2 – 20 (ER 32)	50	70	AD	ER32K	•
BT30DK.70.ER.40.AD	BT30DK	3 – 26 (ER 40)	63	70	AD	ER40K	•
BT40DK.63.ER.16.ADB	BT40DK	1 – 10 (ER 16)	32	63	AD/B	ER16K	•
BT40DK.60.ER.25.ADB	BT40DK	2 – 16 (ER 25)	42	60	AD/B	ER25K	•
BT40DK.70.ER.32.ADB	BT40DK	2 – 20 (ER 32)	50	70	AD/B	ER32K	•
BT40DK.80.ER.40.ADB	BT40DK	3 – 26 (ER 40)	63	80	AD/B	ER40K	•
BT40DK.100.ER.16.ADB	BT40DK	1 – 10 (ER 16)	32	100	AD/B	ER16K	•
BT40DK.100.ER.25.ADB	BT40DK	2 – 16 (ER 25)	42	100	AD/B	ER25K	•
BT40DK.100.ER.32.ADB	BT40DK	2 – 20 (ER 32)	50	100	AD/B	ER32K	•
BT40DK.100.ER.40.ADB	BT40DK	3 – 26 (ER 40)	63	100	AD/B	ER40K	•
BT40DK.160.ER.16.ADB	BT40DK	1 – 10 (ER 16)	32	160	AD/B	ER16K	•
BT40DK.160.ER.25.ADB	BT40DK	2 – 16 (ER 25)	40	160	AD/B	ER25K	•
BT40DK.160.ER.32.ADB	BT40DK	2 – 20 (ER 32)	50	160	AD/B	ER32K	•
BT40DK.160.ER.40.ADB	BT40DK	3 – 26 (ER 40)	63	160	AD/B	ER40K	•

dodávka: s vyváženou upínací maticí, bez montážního klíče

Silový kleštinový upínač

Pro upínací stopky DIN 1835 A+B+E a DIN 6535 HA+HB+HE

(pro větší než 20 mm pouze s redukčním pouzdrem)



Název	Kužel	Rozsah	D	d	A			G 6,3 15.000 min ⁻¹
BT40DK.90.S.20.ADB	BT40DK	3 – 20 (RS20)	53	20	90	AD/B	RS20K	•
BT40DK.90.S.25.ADB	BT40DK	3 – 25 (RS25)	63	25	90	AD/B	RS25K	•
BT40DK.90.S.32.ADB	BT40DK	3 – 32 (RS32)	68	32	90	AD/B	RS32K	•

dodávka: bez montážního klíče

Velikost	20 mm	25 mm	32 mm
Upínací moment	50 - 70 Nm	80 - 100 Nm	80 - 100 Nm
Upínací síla	780 Nm	2000 Nm	2000 Nm



Upínač Weldon pro upínací stopky



Upínač Weldon DIN 6359 pro upínací stopky DIN 1835-B

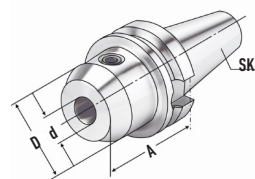

Název	Kužel	D	d	A		G 2,5 25.000 min ⁻¹
BT30DK.50.WE.06.AD	BT30DK	25	6	50	AD	•
BT30DK.50.WE.08.AD	BT30DK	28	8	50	AD	•
BT30DK.50.WE.10.AD	BT30DK	35	10	50	AD	•
BT30DK.50.WE.12.AD	BT30DK	42	12	50	AD	•
BT30DK.50.WE.14.AD	BT30DK	44	14	50	AD	•
BT30DK.63.WE.16.AD	BT30DK	48	16	63	AD	•
BT30DK.63.WE.18.AD	BT30DK	50	18	63	AD	•
BT30DK.63.WE.20.AD	BT30DK	52	20	63	AD	•
BT40DK.50.WE.06.ADB	BT40DK	25	6	50	AD/B	•
BT40DK.50.WE.08.ADB	BT40DK	28	8	50	AD/B	•
BT40DK.63.WE.10.ADB	BT40DK	35	10	63	AD/B	•
BT40DK.63.WE.12.ADB	BT40DK	42	12	63	AD/B	•
BT40DK.63.WE.14.ADB	BT40DK	44	14	63	AD/B	•
BT40DK.63.WE.16.ADB	BT40DK	48	16	63	AD/B	•
BT40DK.63.WE.18.ADB	BT40DK	50	18	63	AD/B	•
BT40DK.63.WE.20.ADB	BT40DK	52	20	63	AD/B	•
BT40DK.90.WE.25.ADB	BT40DK	65	25	90	AD/B	•
BT40DK.100.WE.32.ADB	BT40DK	72	32	100	AD/B	•
BT40DK.120.WE.40.ADB	BT40DK	80	40	120	AD/B	•
BT40DK.100.WE.06.ADB	BT40DK	25	6	100	AD/B	•
BT40DK.100.WE.08.ADB	BT40DK	28	8	100	AD/B	•
BT40DK.100.WE.10.ADB	BT40DK	35	10	100	AD/B	•
BT40DK.100.WE.12.ADB	BT40DK	42	12	100	AD/B	•
BT40DK.100.WE.14.ADB	BT40DK	44	14	100	AD/B	•
BT40DK.100.WE.16.ADB	BT40DK	48	16	100	AD/B	•
BT40DK.100.WE.18.ADB	BT40DK	50	18	100	AD/B	•
BT40DK.100.WE.20.ADB	BT40DK	52	20	100	AD/B	•

od průměru 25 se dvěma upínacími šrouby



Upínač Weldon s chladicími kanály pro upínací stopky



Upínač Weldon DIN 6359 pro upínací stopky DIN 1835-B



Název	Kužel	D	d	A		G 2,5 25.000 min ⁻¹
BT40DK.50.WK.06.ADB	BT40DK	25	6	50	AD/B	•
BT40DK.50.WK.08.ADB	BT40DK	28	8	50	AD/B	•
BT40DK.63.WK.10.ADB	BT40DK	35	10	63	AD/B	•
BT40DK.63.WK.12.ADB	BT40DK	42	12	63	AD/B	•
BT40DK.63.WK.14.ADB	BT40DK	44	14	63	AD/B	•
BT40DK.63.WK.16.ADB	BT40DK	48	16	63	AD/B	•
BT40DK.63.WK.18.ADB	BT40DK	50	18	63	AD/B	•
BT40DK.63.WK.20.ADB	BT40DK	52	20	63	AD/B	•

d = 6 až 18 se dvěma chladicími kanály

d = 20 se čtyřmi chladicími kanály



Upínač pro nástroje s morse stopkou

DIN 228-1 Form B

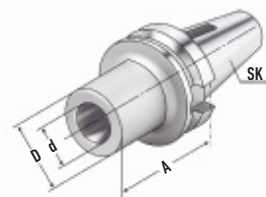

Název	Kužel	MK	D	A		G 6,3 15.000 min ⁻¹
BT30DK.45.MK.1.AD	BT30DK	1	25	45	AD	•
BT30DK.60.MK.2.AD	BT30DK	2	32	60	AD	•
BT30DK.75.MK.3.AD	BT30DK	3	40	75	AD	•
BT40DK.50.MK.1.ADB	BT40DK	1	25	50	AD/B	•
BT40DK.50.MK.2.ADB	BT40DK	2	32	50	AD/B	•
BT40DK.70.MK.3.ADB	BT40DK	3	40	70	AD/B	•
BT40DK.95.MK.4.ADB	BT40DK	4	48	95	AD/B	•



Upínač pro nástrčné frézy

DIN 6357

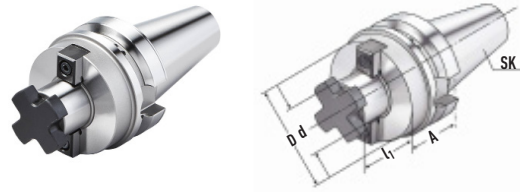

Název	Kužel	d	D	A	l ₁		G 2,5 25.000 min ⁻¹
BT30DK.40.N.16.AD	BT30DK	16	38	40	17	AD	•
BT30DK.40.N.22.AD	BT30DK	22	48	40	19	AD	•
BT30DK.40.N.27.AD	BT30DK	27	58	40	21	AD	•
BT30DK.50.N.32.AD	BT30DK	32	78	50	24	AD	•
BT40DK.40.N.16.ADB	BT40DK	16	38	40	17	AD/B	•
BT40DK.40.N.22.ADB	BT40DK	22	48	40	19	AD/B	•
BT40DK.40.N.27.ADB	BT40DK	27	58	40	21	AD/B	•
BT40DK.50.N.32.ADB	BT40DK	32	78	50	24	AD/B	•
BT40DK.50.N.40.ADB	BT40DK	40	88	50	27	AD/B	•
BT40DK.100.N.16.ADB	BT40DK	16	38	100	17	AD/B	•
BT40DK.100.N.22.ADB	BT40DK	22	48	100	19	AD/B	•
BT40DK.100.N.27.ADB	BT40DK	27	58	100	21	AD/B	•

d = 40: pro velké průměry fréz se čtyřmi závitovými otvory dle DIN 2079

dotávka: s upínacím šroubem s křížovou hlavou a s upínacím šroubem s válcovou hlavou dle DIN 912 pro frézy s vnitřním chlazením



S výstupními otvory chlazení na čele upínače

BT30DK - bez výstupních otvorů chlazení na čele upínače

Upínač pro nástrčné frézy - kombi

DIN 6358

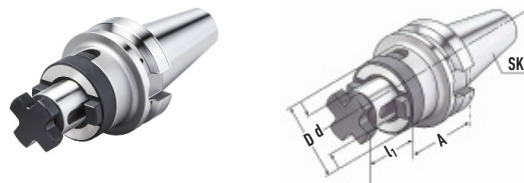

Název	Kužel	d	D	A	l ₁		G 6,3 15.000 min ⁻¹
BT30DK.45.NK.16.AD	BT30DK	16	32	45	17	AD	•
BT30DK.47.NK.22.AD	BT30DK	22	40	47	19	AD	•
BT30DK.49.NK.27.AD	BT30DK	27	48	49	21	AD	•
BT40DK.55.NK.16.ADB	BT40DK	16	32	55	17	AD/B	•
BT40DK.55.NK.22.ADB	BT40DK	22	40	55	19	AD/B	•
BT40DK.55.NK.27.ADB	BT40DK	27	48	55	21	AD/B	•

dotávka: s upínacím šroubem, unašecím kroužkem a perem



Vrtací hlavička



Název	Kužel	Rozsah	D	A			G 6,3 15.000 min ⁻¹
BT30DK.93.V.13.AD	BT30DK	1 - 13	50	93	AD	VT6	•
BT30DK.98.V.16.AD	BT30DK	2,5 - 16	50	98	AD	VT6	•
BT40DK.98.V.13.ADB	BT40DK	1 - 13	50	98	AD/B	VT6	•
BT40DK.103.V.16.ADB	BT40DK	2,5 - 16	50	103	AD/B	VT6	•

použití: pravé / levé otáčky
dodávka: bez montážního klíče

Závitořezná hlava s délkovou kompenzací

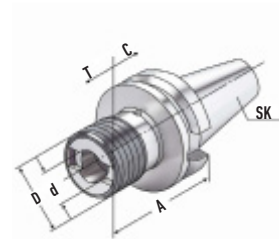

Název	Kužel	Rozsah	D	d	A	T	C	Upínač závitníku
BT40DK.314.Z.1.DK	BT40DK	M3 - M14	38	19	65	7	7	UZB1/UZS1
BT40DK.522.Z.2.DK	BT40DK	M5 - M22	54	31	93	12	12	UZB2/UZS2



Upínač pro frézy se závitem

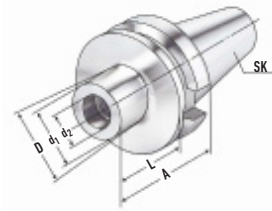

Název	Kužel	M	D	d ₁	d ₂	L	A		G 2,5 25.000 min ⁻¹
BT40DK.52.M.12.ADB	BT40DK	12	24	21	12,5	25	52	AD/B	•
BT40DK.102.M.12.ADB	BT40DK	12	31	21	12,5	75	102	AD/B	•
BT40DK.127.M.12.ADB	BT40DK	12	33	21	12,5	100	127	AD/B	•
BT40DK.52.M.16.ADB	BT40DK	16	29	29	17	25	52	AD/B	•
BT40DK.77.M.16.ADB	BT40DK	16	34	29	17	50	77	AD/B	•
BT40DK.102.M.16.ADB	BT40DK	16	34	29	17	75	102	AD/B	•
BT40DK.127.M.16.ADB	BT40DK	16	36	29	17	100	127	AD/B	•

Doporučené utahovací momenty

M6	10 Nm
M8	25 Nm
M10	40 Nm
M12	50 Nm
M16	60 Nm





Hydro upínač

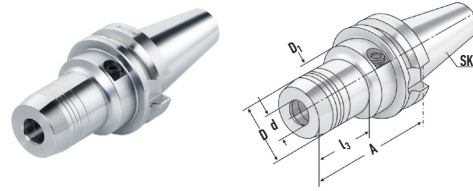

pro válcové upínací stopky DIN 1835 typ A+B+E a DIN 6535 typ HB+HE

(průměry nad 20 mm pouze s redukčním pouzdem)



Název	Kužel	d	D	D ₁	l ₁	l ₂	l ₃	A		G 2,5 25.000 min ⁻¹
BT30DK.60.H.06.AD	BT30DK	6	26	45	37	10	33	60	AD	•
BT30DK.64.H.08.AD	BT30DK	8	28	45	37	10	29	64	AD	•
BT30DK.64.H.10.AD	BT30DK	10	30	45	42	10	37	64	AD	•
BT30DK.72.H.12.AD	BT30DK	12	32	45	47	10	43	72	AD	•
BT30DK.70.H.14.AD	BT30DK	14	34	45	47	10	45	70	AD	•
BT30DK.90.H.16.AD	BT30DK	16	38	45	52	10	52	90	AD	•
BT30DK.90.H.18.AD	BT30DK	18	40	45	52	10	52	90	AD	•
BT30DK.90.H.20.AD	BT30DK	20	42	45	52	10	52	90	AD	•
BT40DK.90.H.06.ADB	BT40DK	6	26	50	37	10	43	90	AD/B	•
BT40DK.90.H.08.ADB	BT40DK	8	28	50	37	10	43,5	90	AD/B	•
BT40DK.90.H.10.ADB	BT40DK	10	30	50	42	10	44	90	AD/B	•
BT40DK.90.H.12.ADB	BT40DK	12	32	50	47	10	44,5	90	AD/B	•
BT40DK.90.H.14.ADB	BT40DK	14	34	50	47	10	47,5	90	AD/B	•
BT40DK.90.H.16.ADB	BT40DK	16	38	50	52	10	47,5	90	AD/B	•
BT40DK.90.H.18.ADB	BT40DK	18	40	50	52	10	47,5	90	AD/B	•
BT40DK.90.H.20.ADB	BT40DK	20	42	50	52	10	47,5	90	AD/B	•
BT40DK.90.H.25.ADB	BT40DK	25	50	50	58	10	51	90	AD/B	•
BT40DK.110.H.32.ADB	BT40DK	32	60	60	64	10	81,5	110	AD/B	•

l₁ = maximální upínací délka

l₂ = maximální délkové nastavení

dodávka: bez montážního klíče



Upínač tepelný 4,5°

pro upínání nástrojů se stopkou TK a HSS

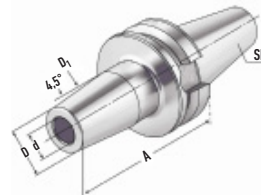

Název	Kužel	d	D	D ₁	l ₁	l ₂	A		G 2,5 25.000 min ⁻¹
BT30DK.80.T4.03.AD	BT30DK	3	11	15	-	-	80	AD	•
BT30DK.80.T4.04.AD	BT30DK	4	14	22	-	5	80	AD	•
BT30DK.80.T4.05.AD	BT30DK	5	16	22	-	5	80	AD	•
BT30DK.80.T4.06.AD	BT30DK	6	21	27	36	10	80	AD	•
BT30DK.80.T4.08.AD	BT30DK	8	21	27	36	10	80	AD	•
BT30DK.80.T4.10.AD	BT30DK	10	24	32	41	10	80	AD	•
BT30DK.90.T4.12.AD	BT30DK	12	24	32	46	10	90	AD	•
BT30DK.90.T4.14.AD	BT30DK	14	27	34	46	10	90	AD	•
BT30DK.90.T4.16.AD	BT30DK	16	27	34	49	10	90	AD	•
BT30DK.90.T4.18.AD	BT30DK	18	33	42	49	10	90	AD	•
BT30DK.90.T4.20.AD	BT30DK	20	33	42	51	10	90	AD	•
BT40DK.80.T4.03.ADB	BT40DK	3	11	15	-	-	80	AD/B	•
BT40DK.80.T4.04.ADB	BT40DK	4	14	22	-	-	80	AD/B	•
BT40DK.80.T4.05.ADB	BT40DK	5	16	22	-	-	80	AD/B	•
BT40DK.90.T4.06.ADB	BT40DK	6	21	27	36	10	90	AD/B	•
BT40DK.90.T4.08.ADB	BT40DK	8	21	27	36	10	90	AD/B	•
BT40DK.90.T4.10.ADB	BT40DK	10	24	32	41	10	90	AD/B	•
BT40DK.90.T4.12.ADB	BT40DK	12	24	32	46	10	90	AD/B	•
BT40DK.90.T4.14.ADB	BT40DK	14	27	34	46	10	90	AD/B	•
BT40DK.90.T4.16.ADB	BT40DK	16	27	34	49	10	90	AD/B	•
BT40DK.90.T4.18.ADB	BT40DK	18	33	42	49	10	90	AD/B	•
BT40DK.90.T4.20.ADB	BT40DK	20	33	42	51	10	90	AD/B	•
BT40DK.100.T4.25.ADB	BT40DK	25	44	53	57	10	100	AD/B	•
BT40DK.100.T4.32.ADB	BT40DK	32	44	53	62	10	100	AD/B	•
BT40DK.120.T4.06.ADB	BT40DK	6	21	27	36	10	120	AD/B	•
BT40DK.120.T4.08.ADB	BT40DK	8	21	27	36	10	120	AD/B	•
BT40DK.120.T4.10.ADB	BT40DK	10	24	32	41	10	120	AD/B	•
BT40DK.120.T4.12.ADB	BT40DK	12	24	32	46	10	120	AD/B	•
BT40DK.120.T4.14.ADB	BT40DK	14	27	34	46	10	120	AD/B	•
BT40DK.120.T4.16.ADB	BT40DK	16	27	34	49	10	120	AD/B	•
BT40DK.120.T4.20.ADB	BT40DK	20	33	42	51	10	120	AD/B	•

pro průměry stopek 3, 4 a 5 mm pouze pro karbidové nástroje

pro průměry stopek 3, 4, a mm s tolerancí h4 a průměry stopek 6 až 32 s tolerancí h6 vhodné pro přístroje, které používají ohřev indukční, kontaktní a teplým vzduchem

l₁ = maximální upínací délka

l₂ = maximální délkové nastavení



Upínač - polotovar

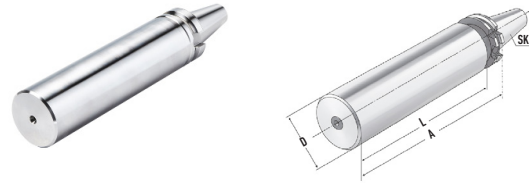

Název	Kužel	D	L	A
BT30DK.160.P.40,5	BT30DK	40,5	138	160
BT40DK.250.P.63	BT40DK	63	215	250

Kužel a příruba kalena a broušena. Těleso měkké pro další opracování.

Kontrolní trn



Název	Kužel	D	A	Max. odchylka soustřednosti
BT30DK.300.K.32	BT30DK	32	300	0,003
BT40DK.300.K.40	BT40DK	40	300	0,003

dodávka: s kontrolním protokolem

Dřevěná kazeta pro kontrolní trn



Název	Kužel	Rozměr
Kazeta pro kontrolní trn	BT30 / BT40 / BT50	460x130x115



Šroub s chladícími drážkami pro vnitřní chlazení nástrojů

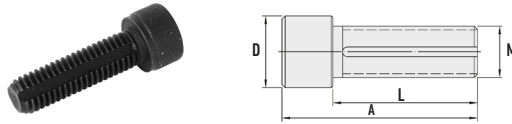

Název	Průměr upínání	M	D	A	L
ISK M8	16	8	13	38	30
ISK M10	27	10	16	45	35
ISK M12	27	12	18	47	35
ISK M16	32	16	24	66	50



Upínací kužely DIN 69893 (HSK-A)

Upínací kužely jsou předvyváženy.

G 6.3 15.000 min⁻¹, G 2,5 25.000 min⁻¹
(G 2.5 vyšší vyvážení za příplatek)

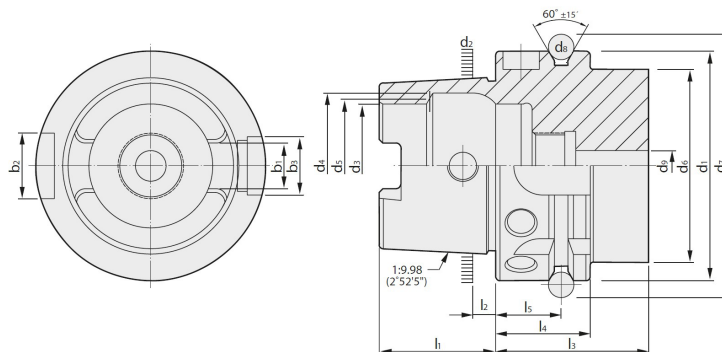

Kužel	d1 h10	d2	d3 H10	d4 H11	d5	d6 max	d7 0 - 0,1	d8	d9 max	l1 0 - 0,2	l2	l3 min	l4 0 - 0,1	l5 ± 0,1	b1 ± 0,04	b2 H10	b3 H10
HSK25A	25	19,006	14	16,4	15	20	28,5	3	3	13	2,5	20	10	4,5	6,05	6	7
HSK32A	32	24,007	17	20,5	19	26	37	4	4,2	16	3,2	35	20	16	7,05	7	9
HSK40A	40	30,007	21	25,5	23	34	45	4	5	20	4	35	20	16	8,05	9	11
HSK50A	50	38,009	26	32	29	42	59,3	7	6,8	25	5	42	26	18	10,54	12	14
HSK63A	63	48,010	34	40	37	53	72,3	7	8,4	32	6,3	42	26	18	12,54	16	18
HSK80A	80	60,012	42	50	46	68	88,8	7	10,2	40	8	42	26	18	16,04	18	20
HSK100A	100	75,013	53	63	58	88	109,75	7	12	50	10	45	29	20	20,02	20	22
HSK125A	125	95,016	67	80	73	111	134,75	7	14	63	12,5	45	29	20	25,02	25	28

materiál: legovaná ocel cementovaná do hl. $0,8 \pm 0,2$ mm, kalená na 60 ± 2 HRC
s pevností v jádru min. 950 N/mm²
černěno a přesně broušeno

NA-U-HSK-1-001-03/23



NA-U-HSK-1-002-03/23



NA-U-HSK-1-002-03/23



NA-U-HSK-2-001-03/23



NA-U-HSK-2-002-03/23



NA-U-HSK-3-001-03/23



NA-U-HSK-4-001-03/23



NA-U-HSK-4-001-03/23



NA-U-HSK-5-001-03/23



NA-U-HSK-5-002-03/23



NA-U-HSK-6-001-03/23



NA-U-HSK-6-002-03/23



NA-U-HSK-6-002-03/23



NA-U-HSK-6-003-03/23



NA-U-HSK-7-001-03/23



NA-U-HSK-8-001-03/23



NA-U-HSK-8-002-03/23



NA-U-HSK-8-003-03/23



NA-U-HSK-9-001-03/23



NA-U-HSK-9-001-03/23



NA-U-HSK-9-001-03/23



NA-U-HSK-9-002-03/23

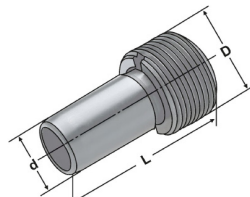

NA-U-HSK-9-002-03/23

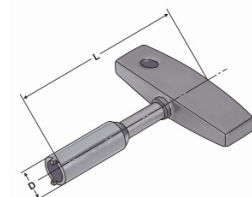



SK
DUAL SK
BT
DUAL BT
HSK
VDI
PRÍSLUŠENSTVÍ

Kleštinový upínač pro kleštiny ER

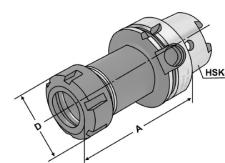

DIN 6499 (ISO 15488)



Název	Kužel	Rozsah	D	A		G 2,5 25.000 min ⁻¹
HSK63A.75.ER.16	HSK63A	1 – 10 (ER 16)	32	75	ER16K	•
HSK63A.75.ER.20	HSK63A	2 – 13 (ER 20)	35	75	ER20K	•
HSK63A.75.ER.25	HSK63A	2 – 16 (ER 25)	42	75	ER25K	•
HSK63A.75.ER.32	HSK63A	2 – 20 (ER 32)	50	75	ER32K	•
HSK63A.85.ER.40	HSK63A	3 – 26 (ER 40)	63	85	ER40K	•
HSK63A.100.ER.16	HSK63A	1 – 10 (ER 16)	32	100	ER16K	•
HSK63A.100.ER.20	HSK63A	2 – 13 (ER 20)	35	100	ER20K	•
HSK63A.100.ER.25	HSK63A	2 – 16 (ER 25)	42	100	ER25K	•
HSK63A.100.ER.32	HSK63A	2 – 20 (ER 32)	50	100	ER32K	•
HSK63A.120.ER.40	HSK63A	3 – 26 (ER 40)	63	120	ER40K	•
HSK63A.130.ER.16	HSK63A	1 – 10 (ER 16)	32	130	ER16K	•
HSK63A.130.ER.20	HSK63A	2 – 13 (ER 20)	35	130	ER20K	•
HSK63A.130.ER.25	HSK63A	2 – 16 (ER 25)	42	130	ER25K	•
HSK63A.130.ER.32	HSK63A	2 – 20 (ER 32)	50	130	ER32K	•
HSK63A.130.ER.40	HSK63A	3 – 26 (ER 40)	63	130	ER40K	•
HSK63A.160.ER.16	HSK63A	1 – 10 (ER 16)	32	160	ER16K	•
HSK63A.160.ER.20	HSK63A	2 – 13 (ER 20)	35	160	ER20K	•
HSK63A.160.ER.25	HSK63A	2 – 16 (ER 25)	42	160	ER25K	•
HSK63A.160.ER.32	HSK63A	2 – 20 (ER 32)	50	160	ER32K	•
HSK63A.160.ER.40	HSK63A	3 – 26 (ER 40)	63	160	ER40K	•
HSK63A.200.ER.16	HSK63A	1 – 10 (ER 16)	32	200	ER16K	•
HSK63A.200.ER.20	HSK63A	2 – 13 (ER 20)	35	200	ER20K	•
HSK63A.200.ER.25	HSK63A	2 – 16 (ER 25)	42	200	ER25K	•
HSK63A.200.ER.32	HSK63A	2 – 20 (ER 32)	50	200	ER32K	•
HSK63A.200.ER.40	HSK63A	3 – 26 (ER 40)	63	200	ER40K	•

dodávka: s vyváženou upínací maticí, bez montážního klíče



Kleštinový upínač pro kleštiny ER



DIN 6499 (ISO 15488)

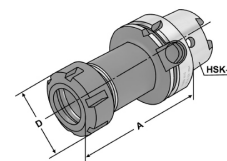

Název	Kužel	Rozsah	D	A		G 2,5 25.000 min ⁻¹
HSK100A.100.ER.16	HSK100A	1 – 10 (ER 16)	32	100	ER16K	•
HSK100A.100.ER.25	HSK100A	2 – 16 (ER 25)	42	100	ER25K	•
HSK100A.100.ER.32	HSK100A	2 – 20 (ER 32)	50	100	ER32K	•
HSK100A.120.ER.40	HSK100A	3 – 26 (ER 40)	63	120	ER40K	•
HSK100A.160.ER.16	HSK100A	1 – 10 (ER 16)	32	160	ER16K	•
HSK100A.160.ER.25	HSK100A	2 – 16 (ER 25)	42	160	ER25K	•
HSK100A.160.ER.32	HSK100A	2 – 20 (ER 32)	50	160	ER32K	•
HSK100A.160.ER.40	HSK100A	3 – 26 (ER 40)	63	160	ER40K	•
HSK100A.200.ER.16	HSK100A	1 – 10 (ER 16)	32	200	ER16K	•
HSK100A.200.ER.25	HSK100A	2 – 16 (ER 25)	42	200	ER25K	•
HSK100A.200.ER.32	HSK100A	2 – 20 (ER 32)	50	200	ER32K	•
HSK100A.200.ER.40	HSK100A	3 – 26 (ER 40)	63	200	ER40K	•

dodávka: s vyváženou upínací maticí, bez montážního klíče



Kleštinový upínač úzký pro kleštiny ER



DIN 6499 (ISO 15488)

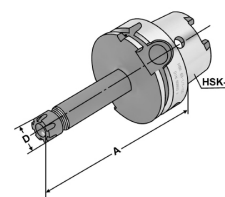



Název	Kužel	Rozsah	D	A		G 2,5 25.000 min ⁻¹
HSK63A.100.ERM.11	HSK63A	1 - 7 (ER 11)	16	100	ER11MK	•
HSK63A.160.ERM.11	HSK63A	1 - 7 (ER 11)	16	160	ER11MK	•
HSK63A.100.ERM.16	HSK63A	1 - 10 (ER 16)	22	100	ER16MK	•
HSK63A.160.ERM.16	HSK63A	1 - 10 (ER 16)	22	160	ER16MK	•
HSK63A.100.ERM.20	HSK63A	1 - 13 (ER20)	28	100	ER20MK	•
HSK63A.160.ERM.20	HSK63A	1 - 13 (ER20)	28	160	ER20MK	•
HSK63A.100.ERM.25	HSK63A	2 - 16 (ER25)	35	100	ER25MK	•
HSK63A.160.ERM.25	HSK63A	2 - 16 (ER25)	35	160	ER25MK	•

dodávka: s vyváženou upínací maticí, bez montážního klíče

Silový kleštinový upínač

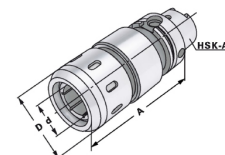
Pro upínací stopky DIN 1835 A+B+E a DIN 6535 HA+HB+HE



Název	Kužel	Rozsah	D	d	A		G 6,3 15.000 min ⁻¹
HSK63A.95.S.20	HSK63A	3 - 20 (RS20)	53	20	95	RS20K	•
HSK63A.100.S.25	HSK63A	3 - 25 (RS25)	63	25	100	RS25K	•
HSK63A.110.S.32	HSK63A	3 - 32 (RS32)	68	32	110	RS32K	•
HSK100A.105.S.20	HSK100A	3 - 20 (RS20)	53	20	105	RS20K	•
HSK100A.105.S.25	HSK100A	3 - 25 (RS25)	63	25	105	RS25K	•
HSK100A.105.S.32	HSK100A	3 - 32 (RS32)	68	32	105	RS32K	•

dodávka: bez montážního klíče

Velikost	20 mm	25 mm	32 mm
Upínací moment	50 - 70 Nm	80 - 100 Nm	80 - 100 Nm
Upínací síla	780 Nm	2000 Nm	2000 Nm



Upínač Weldon pro upínací stopky



Upínač Weldon DIN 6359 pro upínací stopky DIN 1835-B

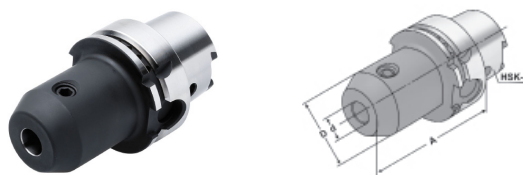

Název	Kužel	D	d	A	G 2,5 25.000 min ⁻¹
HSK63A.65.WE.06	HSK63A	25	6	65	•
HSK63A.65.WE.08	HSK63A	28	8	65	•
HSK63A.65.WE.10	HSK63A	35	10	65	•
HSK63A.80.WE.12	HSK63A	42	12	80	•
HSK63A.80.WE.14	HSK63A	44	14	80	•
HSK63A.80.WE.16	HSK63A	48	16	80	•
HSK63A.80.WE.18	HSK63A	50	18	80	•
HSK63A.80.WE.20	HSK63A	52	20	80	•
HSK63A.110.WE.25	HSK63A	65	25	110	•
HSK63A.110.WE.32	HSK63A	72	32	110	•
HSK63A.125.WE.40	HSK63A	80	40	125	•
HSK63A.100.WE.06	HSK63A	25	6	100	•
HSK63A.100.WE.08	HSK63A	28	8	100	•
HSK63A.100.WE.10	HSK63A	35	10	100	•
HSK63A.100.WE.12	HSK63A	35	12	100	•
HSK63A.100.WE.14	HSK63A	44	14	100	•
HSK63A.100.WE.16	HSK63A	48	16	100	•
HSK63A.100.WE.18	HSK63A	50	18	100	•
HSK63A.100.WE.20	HSK63A	52	20	100	•
HSK63A.130.WE.06	HSK63A	25	6	130	•
HSK63A.130.WE.08	HSK63A	28	8	130	•
HSK63A.130.WE.10	HSK63A	35	10	130	•
HSK63A.130.WE.12	HSK63A	35	12	130	•
HSK63A.130.WE.14	HSK63A	44	14	130	•
HSK63A.130.WE.16	HSK63A	48	16	130	•
HSK63A.130.WE.18	HSK63A	50	18	130	•
HSK63A.130.WE.20	HSK63A	52	20	130	•
HSK63A.160.WE.06	HSK63A	25	6	160	•
HSK63A.160.WE.08	HSK63A	28	8	160	•
HSK63A.160.WE.10	HSK63A	35	10	160	•
HSK63A.160.WE.12	HSK63A	35	12	160	•
HSK63A.160.WE.14	HSK63A	44	14	160	•
HSK63A.160.WE.16	HSK63A	48	16	160	•
HSK63A.160.WE.18	HSK63A	50	18	160	•
HSK63A.160.WE.20	HSK63A	52	20	160	•



Upínač Weldon pro upínací stopky



Upínač Weldon DIN 6359 pro upínací stopky DIN 1835-B

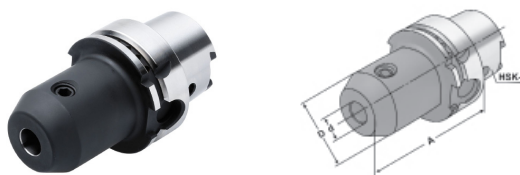

Název	Kužel	D	d	A	G 2,5 25.000 min ⁻¹
HSK100A.80.WE.06	HSK100A	25	6	80	•
HSK100A.80.WE.08	HSK100A	28	8	80	•
HSK100A.80.WE.10	HSK100A	35	10	80	•
HSK100A.80.WE.12	HSK100A	42	12	80	•
HSK100A.80.WE.14	HSK100A	44	14	80	•
HSK100A.100.WE.16	HSK100A	48	16	100	•
HSK100A.100.WE.18	HSK100A	50	18	100	•
HSK100A.100.WE.20	HSK100A	52	20	100	•
HSK100A.100.WE.25	HSK100A	65	25	100	•
HSK100A.100.WE.32	HSK100A	72	32	100	•
HSK100A.105.WE.40	HSK100A	80	40	105	•
HSK100A.160.WE.06	HSK100A	25	6	160	•
HSK100A.160.WE.08	HSK100A	28	8	160	•
HSK100A.160.WE.10	HSK100A	35	10	160	•
HSK100A.160.WE.12	HSK100A	35	12	160	•
HSK100A.160.WE.14	HSK100A	44	14	160	•
HSK100A.160.WE.16	HSK100A	48	16	160	•
HSK100A.160.WE.18	HSK100A	50	18	160	•
HSK100A.160.WE.20	HSK100A	52	20	160	•
HSK100A.160.WE.25	HSK100A	65	25	160	•
HSK100A.160.WE.32	HSK100A	72	32	160	•
HSK100A.160.WE.40	HSK100A	80	40	160	•



Upínač Weldon s chladicími kanály pro upínací stopky



Upínač Weldon DIN 6359 pro upínací stopky DIN 1835-B

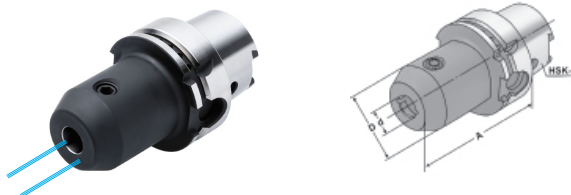

Název	Kužel	d	D	A	G 2,5 25.000 min ⁻¹
HSK63A.65.WK.06	HSK63A	6	25	65	•
HSK63A.65.WK.08	HSK63A	8	28	65	•
HSK63A.65.WK.10	HSK63A	10	35	65	•
HSK63A.80.WK.12	HSK63A	12	42	80	•
HSK63A.80.WK.14	HSK63A	14	44	80	•
HSK63A.80.WK.16	HSK63A	16	48	80	•
HSK63A.80.WK.18	HSK63A	18	50	80	•
HSK63A.80.WK.20	HSK63A	20	52	80	•
HSK63A.110.WK.25	HSK63A	25	65	110	•
HSK63A.110.WK.32	HSK63A	32	72	110	•
HSK63A.125.WK.40	HSK63A	40	80	125	•
HSK63A.100.WK.06	HSK63A	6	25	100	•
HSK63A.100.WK.08	HSK63A	8	28	100	•
HSK63A.100.WK.10	HSK63A	10	35	100	•
HSK63A.100.WK.12	HSK63A	12	42	100	•
HSK63A.100.WK.14	HSK63A	14	44	100	•
HSK63A.100.WK.16	HSK63A	16	48	100	•
HSK63A.100.WK.18	HSK63A	18	50	100	•
HSK63A.100.WK.20	HSK63A	20	52	100	•
HSK63A.130.WK.06	HSK63A	6	25	130	•
HSK63A.130.WK.08	HSK63A	8	28	130	•
HSK63A.130.WK.10	HSK63A	10	35	130	•
HSK63A.130.WK.12	HSK63A	12	42	130	•
HSK63A.130.WK.14	HSK63A	14	44	130	•
HSK63A.130.WK.16	HSK63A	16	48	130	•
HSK63A.130.WK.18	HSK63A	18	50	130	•
HSK63A.130.WK.20	HSK63A	20	52	130	•
HSK100A.80.WK.06	HSK100A	6	25	80	•
HSK100A.80.WK.08	HSK100A	8	28	80	•
HSK100A.80.WK.10	HSK100A	10	35	80	•
HSK100A.80.WK.12	HSK100A	12	42	80	•
HSK100A.80.WK.14	HSK100A	14	44	80	•
HSK100A.100.WK.16	HSK100A	16	48	100	•
HSK100A.100.WK.18	HSK100A	18	50	100	•
HSK100A.100.WK.20	HSK100A	20	52	100	•
HSK100A.100.WK.25	HSK100A	25	65	100	•
HSK100A.100.WK.32	HSK100A	32	72	100	•
HSK100A.105.WK.40	HSK100A	40	80	105	•

od průměr d = 25 se dvěma upínacími šrouby

d = 6 až 18 se dvěma chladicími kanály

d = 20 až 40 se čtyřmi chladicími kanály



Upínač Whistle Notch pro upínací stopky



Upínač Whistle Notch DIN 6359 pro upínací stopky DIN 1835-E

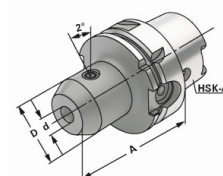

Název	Kužel	d	D	A	G 2,5 25.000 min ⁻¹
HSK63A.80.WN.06	HSK63A	6	25	80	•
HSK63A.80.WN.08	HSK63A	8	28	80	•
HSK63A.80.WN.10	HSK63A	10	35	80	•
HSK63A.90.WN.12	HSK63A	12	42	90	•
HSK63A.90.WN.14	HSK63A	14	44	90	•
HSK63A.100.WN.16	HSK63A	16	48	100	•
HSK63A.100.WN.18	HSK63A	18	50	100	•
HSK63A.100.WN.20	HSK63A	20	52	100	•
HSK63A.110.WN.25	HSK63A	25	65	110	•
HSK63A.110.WN.32	HSK63A	32	72	110	•
HSK100A.90.WN.06	HSK100A	6	25	90	•
HSK100A.90.WN.08	HSK100A	8	28	90	•
HSK100A.90.WN.10	HSK100A	10	35	90	•
HSK100A.100.WN.12	HSK100A	12	42	100	•
HSK100A.100.WN.14	HSK100A	14	44	100	•
HSK100A.100.WN.16	HSK100A	16	48	100	•
HSK100A.100.WN.18	HSK100A	18	50	100	•
HSK100A.110.WN.20	HSK100A	20	52	110	•
HSK100A.120.WN.25	HSK100A	25	65	120	•
HSK100A.120.WN.32	HSK100A	32	72	120	•
HSK100A.120.WN.40	HSK100A	40	80	120	•

od průměr d = 25 se dvěma upínacími šrouby



Upínač pro nástroje s morse stopkou



DIN 228-1 Form B

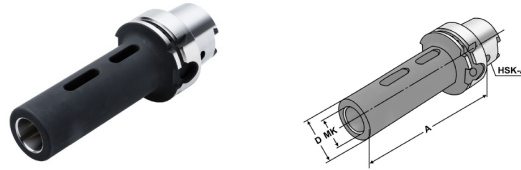

Název	Kužel	MK	D	A	G 6,3 15.000 min ⁻¹
HSK63A.100.MK.1	HSK63A	1	25	100	•
HSK63A.120.MK.2	HSK63A	2	32	120	•
HSK63A.140.MK.3	HSK63A	3	40	140	•
HSK63A.160.MK.4	HSK63A	4	48	160	•
HSK100A.110.MK.1	HSK100A	1	25	110	•
HSK100A.120.MK.2	HSK100A	2	32	120	•
HSK100A.150.MK.3	HSK100A	3	40	150	•
HSK100A.170.MK.4	HSK100A	4	48	170	•
HSK100A.200.MK.5	HSK100A	5	63	200	•

Upínač pro nástroje s morse stopkou a závitem dle DIN228-A

DIN 228-1 Form A



Název	Kužel	MK	D	A	G 6,3 15.000 min ⁻¹
HSK63A.100.MKS.1	HSK63A	1	25	100	•
HSK63A.120.MKS.2	HSK63A	2	32	120	•
HSK63A.140.MKS.3	HSK63A	3	40	140	•
HSK63A.160.MKS.4	HSK63A	4	48	160	•
HSK100A.110.MKS.1	HSK100A	1	25	110	•
HSK100A.120.MKS.2	HSK100A	2	32	120	•
HSK100A.150.MKS.3	HSK100A	3	40	150	•
HSK100A.170.MKS.4	HSK100A	4	48	170	•
HSK100A.200.MKS.5	HSK100A	5	63	200	•



Upínač pro nástrčné frézy



DIN 6357

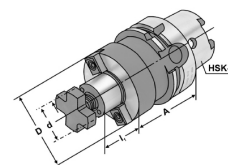

Název	Kužel	d	D	A	I ₁	G 2,5 25.000 min ⁻¹
HSK63A.50.N.16	HSK63A	16	38	50	17	•
HSK63A.50.N.22	HSK63A	22	48	50	19	•
HSK63A.60.N.27	HSK63A	27	58	60	21	•
HSK63A.60.N.32	HSK63A	32	78	60	24	•
HSK63A.60.N.40	HSK63A	40	88	60	27	•
HSK63A.100.N.16	HSK63A	16	38	100	17	•
HSK63A.100.N.22	HSK63A	22	48	100	19	•
HSK63A.100.N.27	HSK63A	27	58	100	21	•
HSK63A.100.N.32	HSK63A	32	78	100	24	•
HSK63A.100.N.40	HSK63A	40	88	100	27	•
HSK63A.160.N.16	HSK63A	16	38	160	17	•
HSK63A.160.N.22	HSK63A	22	48	160	19	•
HSK63A.160.N.27	HSK63A	27	58	160	21	•
HSK63A.160.N.32	HSK63A	32	78	160	24	•
HSK63A.160.N.40	HSK63A	40	88	160	27	•
HSK100A.50.N.16	HSK100A	16	38	50	17	•
HSK100A.50.N.22	HSK100A	22	48	50	19	•
HSK100A.50.N.27	HSK100A	27	58	50	21	•
HSK100A.50.N.32	HSK100A	32	78	50	24	•
HSK100A.70.N.40	HSK100A	40	88	70	27	•
HSK100A.70.N.60	HSK100A	60	130	70	40	•
HSK100A.100.N.16	HSK100A	16	38	100	17	•
HSK100A.100.N.22	HSK100A	22	48	100	19	•
HSK100A.100.N.27	HSK100A	27	58	100	21	•
HSK100A.100.N.32	HSK100A	32	78	100	24	•
HSK100A.100.N.40	HSK100A	40	88	100	27	•
HSK100A.160.N.16	HSK100A	16	38	160	17	•
HSK100A.160.N.22	HSK100A	22	48	160	19	•
HSK100A.160.N.27	HSK100A	27	58	160	21	•
HSK100A.160.N.32	HSK100A	32	78	160	24	•
HSK100A.160.N.40	HSK100A	40	88	160	27	•

d = 40/d = 60: pro velké průměry fréz se čtyřmi závitovými otvory dle DIN 2079

dobřívka: s upínacím šroubem s křížovou hlavou a s upínacím šroubem s válcovou hlavou dle DIN 912 pro frézy s vnitřním chlazením

pro d = 60 pouze se čtyřmi upínacími šrouby dle DIN 912



S výstupními otvory chlazení na čele upínače



Upínač pro nástrčné frézy - kombi



DIN 6358

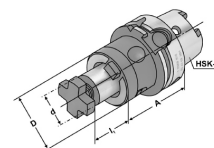

Název	Kužel	d	D	A	I ₁	G 6,3 15.000 min ⁻¹
HSK63A.60.NK.16	HSK63A	16	32	60	17	•
HSK63A.60.NK.22	HSK63A	22	40	60	19	•
HSK63A.60.NK.27	HSK63A	27	48	60	21	•
HSK63A.60.NK.32	HSK63A	32	58	60	24	•
HSK63A.70.NK.40	HSK63A	40	70	70	27	•
HSK63A.100.NK.16	HSK63A	16	32	100	17	•
HSK63A.100.NK.22	HSK63A	22	40	100	19	•
HSK63A.100.NK.27	HSK63A	27	48	100	21	•
HSK63A.100.NK.32	HSK63A	32	58	100	24	•
HSK100A.60.NK.16	HSK100A	16	32	60	17	•
HSK100A.60.NK.22	HSK100A	22	40	60	19	•
HSK100A.60.NK.27	HSK100A	27	48	60	21	•
HSK100A.60.NK.32	HSK100A	32	58	60	24	•
HSK100A.70.NK.40	HSK100A	40	70	70	27	•

dodávka: s upínacím šroubem, unašecím kroužkem a perem



Závitořezná hlava s délkovou kompenzací

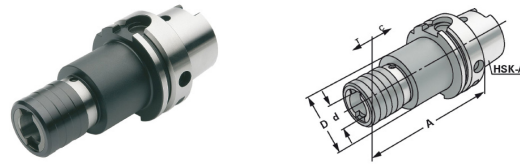

Název	Kužel	Rozsah	D	d	A	T	C	Upínač závitníku
HSK63A.314.Z.1.DK	HSK63A	M3 - M14	50	19	102	7	7	UZB1/UZS1
HSK63A.522.Z.2.DK	HSK63A	M5 - M22	54	31	140	12	12	UZB2/UZS2
HSK63A.1436.Z.3.DK	HSK63A	M14 - M36	86	48	210	17,5	17,5	UZB3/UZS3
HSK100A.314.Z.1.DK	HSK100A	M3 - M14	38	19	112	7	7	UZB1/UZS1
HSK100A.522.Z.2.DK	HSK100A	M5 - M22	54	31	148	12	12	UZB2/UZS2
HSK100A.1436.Z.3.DK	HSK100A	M14 - M36	86	48	210	17,5	17,5	UZB3/UZS3

Závitořezná hlava bez délkové kompenzace

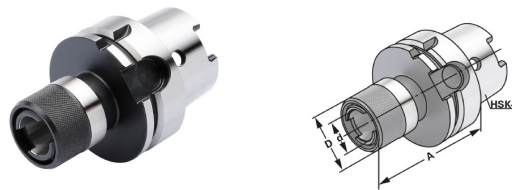

Název	Kužel	Rozsah	D	d	A	Upínač závitníku
HSK63A.314.Z.1.BK	HSK63A	M3 - M14	38	19	65	UZB1/UZS1
HSK63A.522.Z.2.BK	HSK63A	M5 - M22	54	31	100	UZB2/UZS2
HSK100A.314.Z.1.BK	HSK100A	M3 - M14	38	19	80	UZB1/UZS1
HSK100A.522.Z.2.BK	HSK100A	M5 - M22	54	31	90	UZB2/UZS2
HSK100A.1436.Z.3.BK	HSK100A	M14 - M36	86	48	130	UZB3/UZS3



Upínač pro vrtáky s vyměnitelnými destičkami



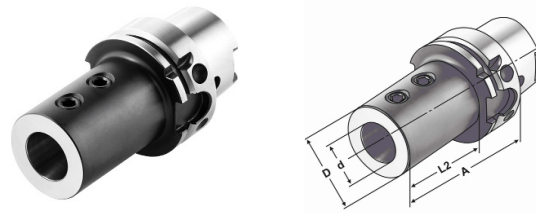

typ E1

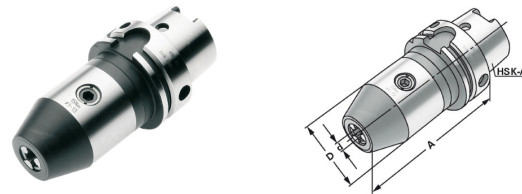

Název	Kužel	d	D	A	G 6,3 15.000 min ⁻¹
HSK63A.80.E1.20	HSK63A	20	40	80	•
HSK63A.90.E1.25	HSK63A	25	45	90	•
HSK63A.90.E1.32	HSK63A	32	52	90	•
HSK63A.105.E1.40	HSK63A	40	63	105	•

Vrtací hlavička



Název	Kužel	Rozsah d	D	A		G 6,3 15.000 min ⁻¹
HSK63A.85.V.8	HSK63A	0 - 8	36	85	VT4	•
HSK63A.104.V.13	HSK63A	1 - 13	50	104	VT6	•
HSK63A.109.V.16	HSK63A	2,5 - 16	50	109	VT6	•
HSK100A.107.V.13	HSK100A	1 - 13	50	107	VT6	•
HSK100A.112.V.16	HSK100A	2,5 - 16	50	112	VT6	•

použití: pravé / levé otáčky

dodávka: bez montážního klíče



Upínač pro frézy se závitem

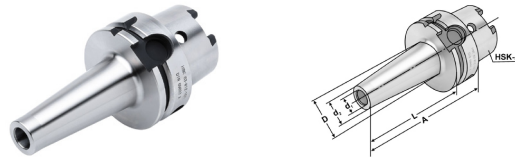

Název	Kužel	M	D	d ₂	d ₁	L	A	G 2,5 25.000 min ⁻¹
HSK63A.51.M.06	HSK63A	6	13	10	6,5	25	51	•
HSK63A.51.M.08	HSK63A	8	15	13	8,5	25	51	•
HSK63A.76.M.08	HSK63A	8	23	13	8,5	50	76	•
HSK63A.101.M.08	HSK63A	8	23	13	8,5	75	101	•
HSK63A.51.M.10	HSK63A	10	20	18	10,5	25	51	•
HSK63A.76.M.10	HSK63A	10	23	18	10,5	50	76	•
HSK63A.126.M.10	HSK63A	10	32	18	10,5	100	126	•
HSK63A.176.M.10	HSK63A	10	37	18	10,5	150	176	•
HSK63A.51.M.12	HSK63A	12	24	21	12,5	25	51	•
HSK63A.76.M.12	HSK63A	12	24	21	12,5	50	76	•
HSK63A.101.M.12	HSK63A	12	31	21	12,5	75	101	•
HSK63A.126.M.12	HSK63A	12	33	21	12,5	100	126	•
HSK63A.176.M.12	HSK63A	12	40	21	12,5	150	176	•
HSK63A.51.M.16	HSK63A	16	29	29	17	25	51	•
HSK63A.76.M.16	HSK63A	16	34	29	17	50	76	•
HSK63A.101.M.16	HSK63A	16	34	29	17	75	101	•
HSK63A.126.M.16	HSK63A	16	36	29	17	100	126	•
HSK63A.176.M.16	HSK63A	16	43	29	17	150	176	•
HSK100A.79.M.08	HSK100A	8	23	13	8,5	50	79	•
HSK100A.79.M.10	HSK100A	10	23	18	10,5	50	79	•
HSK100A.129.M.10	HSK100A	10	32	18	10,5	100	129	•
HSK100A.179.M.10	HSK100A	10	37	18	10,5	150	179	•
HSK100A.79.M.12	HSK100A	12	24	21	12,5	50	79	•
HSK100A.129.M.12	HSK100A	12	33	21	12,5	100	129	•
HSK100A.179.M.12	HSK100A	12	40	21	12,5	150	179	•
HSK100A.79.M.16	HSK100A	16	34	29	17	50	79	•
HSK100A.129.M.16	HSK100A	16	36	29	17	100	129	•
HSK100A.179.M.16	HSK100A	16	43	29	17	150	179	•

Doporučené utahovací momenty

M6	10 Nm
M8	25 Nm
M10	40 Nm
M12	50 Nm
M16	60 Nm



Hydro upínač



pro válcové upínací stopky DIN 1835 typ A+B+E a DIN 6535 typ HB+HE

(průměry nad 20 mm pouze s redukčním pouzdem)

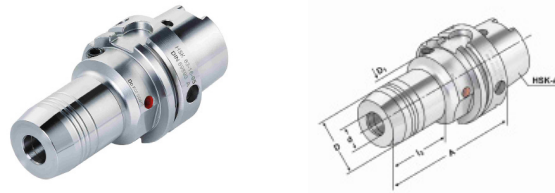

Název	Kužel	d	D	D ₁	l ₁	l ₂	l ₃	A	G 2,5 25.000 min ⁻¹
HSK63A.80.H.06	HSK63A	6	26	50	37	10	33	80	•
HSK63A.80.H.08	HSK63A	8	28	50	37	10	33,5	80	•
HSK63A.85.H.10	HSK63A	10	30	50	42	10	39	85	•
HSK63A.90.H.12	HSK63A	12	32	50	47	10	44,5	90	•
HSK63A.90.H.14	HSK63A	14	34	50	47	10	46	90	•
HSK63A.95.H.16	HSK63A	16	38	50	52	10	51,5	95	•
HSK63A.95.H.18	HSK63A	18	40	50	52	10	52	95	•
HSK63A.100.H.20	HSK63A	20	42	50	52	10	58	100	•
HSK63A.120.H.25	HSK63A	25	50	50	58	10	94	120	•
HSK63A.125.H.32	HSK63A	32	60	53	62	10	83	125	•
HSK63A.150.H.06	HSK63A	6	26	50	37	10	103	150	•
HSK63A.150.H.08	HSK63A	8	28	50	37	10	104	150	•
HSK63A.150.H.10	HSK63A	10	30	50	42	10	104	150	•
HSK63A.150.H.12	HSK63A	12	32	50	47	10	105	150	•
HSK63A.150.H.14	HSK63A	14	34	50	47	10	105	150	•
HSK63A.150.H.16	HSK63A	16	38	50	52	10	106,5	150	•
HSK63A.150.H.18	HSK63A	18	40	50	52	10	107	150	•
HSK63A.150.H.20	HSK63A	20	42	50	52	10	108	150	•
HSK63A.150.H.25	HSK63A	25	50	50	58	10	124	150	•
HSK63A.200.H.06	HSK63A	6	26	50	37	10	153	200	•
HSK63A.200.H.08	HSK63A	8	28	50	37	10	154	200	•
HSK63A.200.H.10	HSK63A	10	30	50	42	10	154	200	•
HSK63A.200.H.12	HSK63A	12	32	50	47	10	155	200	•
HSK63A.200.H.14	HSK63A	14	34	50	47	10	155	200	•
HSK63A.200.H.16	HSK63A	16	38	50	52	10	156,5	200	•
HSK63A.200.H.18	HSK63A	18	40	50	52	10	157	200	•
HSK63A.200.H.20	HSK63A	20	42	50	52	10	158	200	•
HSK63A.200.H.25	HSK63A	25	50	50	58	10	174	200	•

l₁ = maximální upínací délka

l₂ = maximální délkové nastavení

dodávka: bez montážního klíče



Hydro upínač



pro válcové upínací stopky DIN 1835 typ A+B+E a DIN 6535 typ HB+HE

(průměry nad 20 mm pouze s redukčním pouzdem)

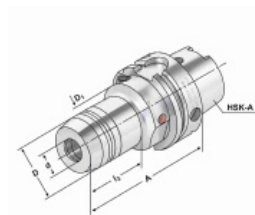

Název	Kužel	d	D	D ₁	l ₁	l ₂	l ₃	A	G 2,5 25.000 min ⁻¹
HSK100A.85.H.06	HSK100A	6	26	63	37	10	33	85	•
HSK100A.85.H.08	HSK100A	8	28	63	37	10	33,5	85	•
HSK100A.90.H.10	HSK100A	10	30	63	42	10	39	90	•
HSK100A.95.H.12	HSK100A	12	32	63	47	10	44,5	95	•
HSK100A.95.H.14	HSK100A	14	34	63	47	10	46	95	•
HSK100A.100.H.16	HSK100A	16	38	63	52	10	53	100	•
HSK100A.100.H.18	HSK100A	18	40	63	52	10	52	100	•
HSK100A.105.H.20	HSK100A	20	42	63	52	10	51	105	•
HSK100A.115.H.25	HSK100A	25	50	63	58	10	64	115	•
HSK100A.120.H.32	HSK100A	32	60	63	62	10	61	120	•
HSK100A.150.H.06	HSK100A	6	26	63	37	10	97	150	•
HSK100A.150.H.08	HSK100A	8	28	63	37	10	98	150	•
HSK100A.150.H.10	HSK100A	10	30	63	42	10	99	150	•
HSK100A.150.H.12	HSK100A	12	32	63	47	10	99	150	•
HSK100A.150.H.14	HSK100A	14	34	63	47	10	101	150	•
HSK100A.150.H.16	HSK100A	16	38	63	52	10	101	150	•
HSK100A.150.H.18	HSK100A	18	40	63	52	10	102	150	•
HSK100A.150.H.20	HSK100A	20	42	63	52	10	101	150	•
HSK100A.150.H.25	HSK100A	25	50	63	58	10	99	150	•
HSK100A.150.H.32	HSK100A	32	60	63	62	10	100	150	•
HSK100A.200.H.06	HSK100A	6	26	50	37	10	56	200	•
HSK100A.200.H.08	HSK100A	8	28	50	37	10	55,5	200	•
HSK100A.200.H.10	HSK100A	10	30	50	42	10	55	200	•
HSK100A.200.H.12	HSK100A	12	32	50	47	10	54,5	200	•
HSK100A.200.H.14	HSK100A	14	34	50	47	10	53	200	•
HSK100A.200.H.16	HSK100A	16	38	50	52	10	52,5	200	•
HSK100A.200.H.18	HSK100A	18	40	50	52	10	52	200	•
HSK100A.200.H.20	HSK100A	20	42	50	52	10	51	200	•
HSK100A.200.H.25	HSK100A	25	50	50	58	10	-	200	•
HSK100A.200.H.32	HSK100A	32	60	60	62	10	-	200	•

l₁ = maximální upínací délka

l₂ = maximální délkové nastavení

dodávka: bez montážního klíče



Upínač tepelný 4,5°

pro upínání nástrojů se stopkou TK a HSS

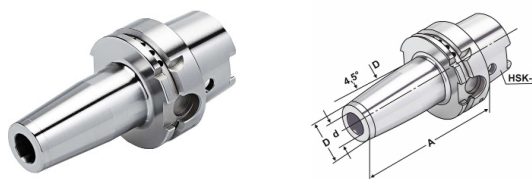

Název	Kužel	d	D	D ₁	l ₁	l ₂	A	G 2,5 25.000 min ⁻¹
HSK63A.80.T4.03	HSK63A	3	11	15	10	-	80	•
HSK63A.120.T4.03	HSK63A	3	11	15	10	-	120	•
HSK63A.160.T4.03	HSK63A	3	11	15	10	-	160	•
HSK63A.80.T4.04	HSK63A	4	14	22	20	5	80	•
HSK63A.120.T4.04	HSK63A	4	14	22	20	5	120	•
HSK63A.160.T4.04	HSK63A	4	14	22	20	5	160	•
HSK63A.80.T4.05	HSK63A	5	16	22	20	5	80	•
HSK63A.120.T4.05	HSK63A	5	16	22	20	5	120	•
HSK63A.160.T4.05	HSK63A	5	16	22	20	5	160	•
HSK63A.80.T4.06	HSK63A	6	21	27	36	10	80	•
HSK63A.120.T4.06	HSK63A	6	21	27	36	10	120	•
HSK63A.160.T4.06	HSK63A	6	21	27	36	10	160	•
HSK63A.200.T4.06	HSK63A	6	21	27	36	10	200	•
HSK63A.80.T4.08	HSK63A	8	21	27	36	10	80	•
HSK63A.120.T4.08	HSK63A	8	21	27	36	10	120	•
HSK63A.160.T4.08	HSK63A	8	21	27	36	10	160	•
HSK63A.200.T4.08	HSK63A	8	21	27	36	10	200	•
HSK63A.85.T4.10	HSK63A	10	24	32	41	10	85	•
HSK63A.120.T4.10	HSK63A	10	24	32	41	10	120	•
HSK63A.160.T4.10	HSK63A	10	24	32	41	10	160	•
HSK63A.200.T4.10	HSK63A	10	24	32	41	10	200	•
HSK63A.90.T4.12	HSK63A	12	24	32	46	10	90	•
HSK63A.120.T4.12	HSK63A	12	24	32	46	10	120	•
HSK63A.160.T4.12	HSK63A	12	24	32	46	10	160	•
HSK63A.200.T4.12	HSK63A	12	24	32	46	10	200	•

pro průměry stopek 3, 4 a 5 mm pouze pro karbidové nástroje
 pro průměry stopek 3,4, a mm s tolerancí h4 a průměry stopek 6 až 32 s tolerancí h6
 vhodné pro přístroje, které používají ohřev indukční, kontaktní a teplým vzduchem

l₁ = maximální upínací délka

l₂ = maximální délkové nastavení



Upínač tepelný 4,5°

pro upínání nástrojů se stopkou TK a HSS

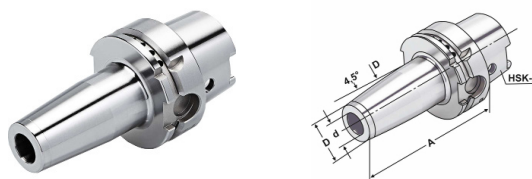

Název	Kužel	d	D	D ₁	l ₁	l ₂	A	G 2,5 25.000 min ⁻¹
HSK63A.90.T4.14	HSK63A	14	27	34	46	10	90	•
HSK63A.120.T4.14	HSK63A	14	27	34	46	10	120	•
HSK63A.160.T4.14	HSK63A	14	27	34	46	10	160	•
HSK63A.95.T4.16	HSK63A	16	27	34	49	10	95	•
HSK63A.120.T4.16	HSK63A	16	27	34	49	10	120	•
HSK63A.160.T4.16	HSK63A	16	27	34	49	10	160	•
HSK63A.200.T4.16	HSK63A	16	27	34	49	10	200	•
HSK63A.95.T4.18	HSK63A	18	33	42	49	10	95	•
HSK63A.120.T4.18	HSK63A	18	33	42	49	10	120	•
HSK63A.160.T4.18	HSK63A	18	33	42	49	10	160	•
HSK63A.200.T4.18	HSK63A	18	33	42	49	10	200	•
HSK63A.100.T4.20	HSK63A	20	33	42	51	10	100	•
HSK63A.120.T4.20	HSK63A	20	33	42	51	10	120	•
HSK63A.160.T4.20	HSK63A	20	33	42	51	10	160	•
HSK63A.200.T4.20	HSK63A	20	33	42	51	10	200	•
HSK63A.115.T4.25	HSK63A	25	44	53	57	10	115	•
HSK63A.120.T4.25	HSK63A	25	44	53	57	10	120	•
HSK63A.160.T4.25	HSK63A	25	44	53	57	10	160	•
HSK63A.200.T4.25	HSK63A	25	44	53	57	10	200	•
HSK63A.120.T4.32	HSK63A	32	44	53	61	10	120	•
HSK63A.160.T4.32	HSK63A	32	44	53	61	10	160	•
HSK63A.200.T4.32	HSK63A	32	44	53	61	10	200	•

pro průměry stopek 3, 4 a 5 mm pouze pro karbidové nástroje
 pro průměry stopek 3,4, a mm s tolerancí h4 a průměry stopek 6 až 32 s tolerancí h6
 vhodné pro přístroje, které používají ohřev indukční, kontaktní a teplým vzduchem

l₁ = maximální upínací délka

l₂ = maximální délkové nastavení



Upínač tepelný 4,5°

pro upínání nástrojů se stopkou TK a HSS

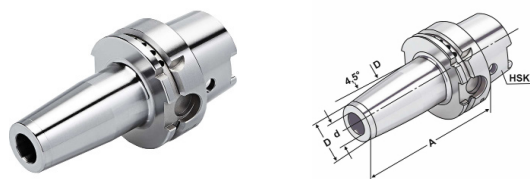

Název	Kužel	d	D	D ₁	l ₁	l ₂	A	G 2,5 25.000 min ⁻¹
HSK100A.85.T4.04	HSK100A	4	14	22	-	-	85	•
HSK100A.85.T4.05	HSK100A	5	16	22	-	-	85	•
HSK100A.85.T4.06	HSK100A	6	21	27	36	10	85	•
HSK100A.120.T4.06	HSK100A	6	21	27	36	10	120	•
HSK100A.160.T4.06	HSK100A	6	21	27	36	10	160	•
HSK100A.200.T4.06	HSK100A	6	21	27	36	10	200	•
HSK100A.250.T4.06	HSK100A	6	21	27	36	10	250	•
HSK100A.85.T4.08	HSK100A	8	21	27	36	10	85	•
HSK100A.120.T4.08	HSK100A	8	21	27	36	10	120	•
HSK100A.160.T4.08	HSK100A	8	21	27	36	10	160	•
HSK100A.200.T4.08	HSK100A	8	21	27	36	10	200	•
HSK100A.250.T4.08	HSK100A	8	21	27	36	10	250	•
HSK100A.90.T4.10	HSK100A	10	24	32	41	10	90	•
HSK100A.120.T4.10	HSK100A	10	24	32	41	10	120	•
HSK100A.160.T4.10	HSK100A	10	24	32	41	10	160	•
HSK100A.200.T4.10	HSK100A	10	24	32	41	10	200	•
HSK100A.250.T4.10	HSK100A	10	24	32	41	10	250	•
HSK100A.95.T4.12	HSK100A	12	24	32	46	10	95	•
HSK100A.120.T4.12	HSK100A	12	24	32	46	10	120	•
HSK100A.160.T4.12	HSK100A	12	24	32	46	10	160	•
HSK100A.200.T4.12	HSK100A	12	24	32	46	10	200	•
HSK100A.250.T4.12	HSK100A	12	24	32	46	10	250	•

pro průměry stopek 3, 4 a 5 mm pouze pro karbidové nástroje
 pro průměry stopek 3,4, a mm s tolerancí h4 a průměry stopek 6 až 32 s tolerancí h6
 vhodné pro přístroje, které používají ohřev indukční, kontaktní a teplým vzduchem

l₁ = maximální upínací délka

l₂ = maximální délkové nastavení



Upínač tepelný 4,5°

pro upínání nástrojů se stopkou TK a HSS

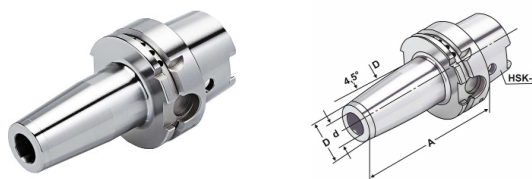

Název	Kužel	d	D	D ₁	l ₁	l ₂	A	G 2,5 25.000 min ⁻¹
HSK100A.95.T4.14	HSK100A	14	27	34	46	10	95	•
HSK100A.120.T4.14	HSK100A	14	27	34	46	10	120	•
HSK100A.160.T4.14	HSK100A	14	27	34	46	10	160	•
HSK100A.200.T4.14	HSK100A	14	27	34	46	10	200	•
HSK100A.250.T4.14	HSK100A	14	27	34	46	10	250	•
HSK100A.100.T4.16	HSK100A	16	27	34	49	10	100	•
HSK100A.120.T4.16	HSK100A	16	27	34	49	10	120	•
HSK100A.160.T4.16	HSK100A	16	27	34	49	10	160	•
HSK100A.200.T4.16	HSK100A	16	27	34	49	10	200	•
HSK100A.250.T4.16	HSK100A	16	27	34	49	10	250	•
HSK100A.100.T4.18	HSK100A	18	33	42	49	10	100	•
HSK100A.120.T4.18	HSK100A	18	33	42	49	10	120	•
HSK100A.160.T4.18	HSK100A	18	33	42	49	10	160	•
HSK100A.200.T4.18	HSK100A	18	33	42	49	10	200	•
HSK100A.105.T4.20	HSK100A	20	33	42	51	10	105	•
HSK100A.120.T4.20	HSK100A	20	33	42	51	10	120	•
HSK100A.160.T4.20	HSK100A	20	33	42	51	10	160	•
HSK100A.200.T4.20	HSK100A	20	33	42	51	10	200	•
HSK100A.120.T4.25	HSK100A	25	44	53	57	10	120	•
HSK100A.160.T4.25	HSK100A	25	44	53	57	10	160	•
HSK100A.200.T4.25	HSK100A	25	44	53	57	10	200	•
HSK100A.120.T4.32	HSK100A	32	44	53	61	10	120	•
HSK100A.160.T4.32	HSK100A	32	44	53	61	10	160	•
HSK100A.200.T4.32	HSK100A	32	44	53	61	10	200	•
HSK100A.150.T4.40	HSK100A	40	78	90	90	10	150	•
HSK100A.150.T4.50	HSK100A	50	78	90	90	10	150	•

pro průměry stopek 3, 4 a 5 mm pouze pro karbidové nástroje

pro průměry stopek 3,4, a mm s tolerancí h4 a průměry stopek 6 až 32 s tolerancí h6 vhodné pro přístroje, které používají ohřev indukční, kontaktní a teplým vzduchem

l₁ = maximální upínací délka

l₂ = maximální délkové nastavení



Upínač tepelný 4,5° s chladicími kanály



pro upínání nástrojů se stopkou TK a HSS

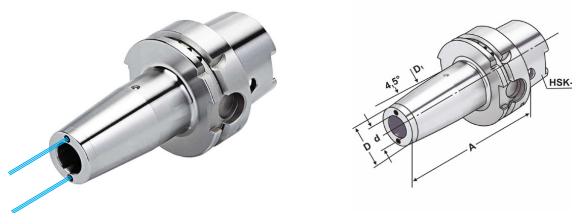

Název	Kužel	d	D	D ₁	l ₁	l ₂	A	G 2,5 25.000 min ⁻¹
HSK63A.80.TK4.03	HSK63A	3	11	15	-	-	80	•
HSK63A.120.TK4.03	HSK63A	3	11	15	-	-	120	•
HSK63A.80.TK4.04	HSK63A	4	14	22	-	-	80	•
HSK63A.120.TK4.04	HSK63A	4	14	22	-	-	120	•
HSK63A.80.TK4.05	HSK63A	5	16	22	-	-	80	•
HSK63A.120.TK4.05	HSK63A	5	16	22	-	-	120	•
HSK63A.80.TK4.06	HSK63A	6	21	27	36	10	80	•
HSK63A.120.TK4.06	HSK63A	6	21	27	36	10	120	•
HSK63A.160.TK4.06	HSK63A	6	21	27	36	10	160	•
HSK63A.80.TK4.08	HSK63A	8	21	27	36	10	80	•
HSK63A.120.TK4.08	HSK63A	8	21	27	36	10	120	•
HSK63A.160.TK4.08	HSK63A	8	21	27	36	10	160	•
HSK63A.85.TK4.10	HSK63A	10	24	32	41	10	85	•
HSK63A.120.TK4.10	HSK63A	10	24	32	41	10	120	•
HSK63A.160.TK4.10	HSK63A	10	24	32	41	10	160	•
HSK63A.90.TK4.12	HSK63A	12	24	32	46	10	90	•
HSK63A.120.TK4.12	HSK63A	12	24	32	46	10	120	•
HSK63A.160.TK4.12	HSK63A	12	24	32	46	10	160	•
HSK63A.90.TK4.14	HSK63A	14	27	34	46	10	90	•
HSK63A.120.TK4.14	HSK63A	14	27	34	46	10	120	•
HSK63A.160.TK4.14	HSK63A	14	27	34	46	10	160	•
HSK63A.95.TK4.16	HSK63A	14	27	34	46	10	95	•
HSK63A.120.TK4.16	HSK63A	16	27	34	49	10	120	•
HSK63A.160.TK4.16	HSK63A	16	27	34	49	10	160	•
HSK63A.95.TK4.18	HSK63A	16	27	34	49	10	95	•
HSK63A.120.TK4.18	HSK63A	18	33	42	49	10	120	•
HSK63A.160.TK4.18	HSK63A	18	33	42	49	10	160	•
HSK63A.100.TK4.20	HSK63A	20	33	42	51	10	100	•
HSK63A.120.TK4.20	HSK63A	20	33	42	51	10	120	•
HSK63A.160.TK4.20	HSK63A	20	33	42	51	10	160	•
HSK63A.115.TK4.25	HSK63A	25	44	53	58	10	115	•
HSK63A.120.TK4.25	HSK63A	25	44	53	58	10	120	•
HSK63A.160.TK4.25	HSK63A	25	44	53	58	10	160	•
HSK63A.120.TK4.32	HSK63A	32	44	53	61	10	120	•
HSK63A.160.TK4.32	HSK63A	32	44	53	61	10	160	•

pro průměry stopek 3, 4 a 5 mm pouze pro karbidové nástroje
 pro průměry stopek 3,4, a mm s tolerancí h4 a průměry stopek 6 až 32 s tolerancí h6
 vhodné pro přístroje, které používají ohřev indukční, kontaktní a teplým vzduchem

l₁ = maximální upínací délka

l₂ = maximální délkové nastavení



Upínač tepelný 4,5° s chladicími kanály



pro upínání nástrojů se stopkou TK a HSS

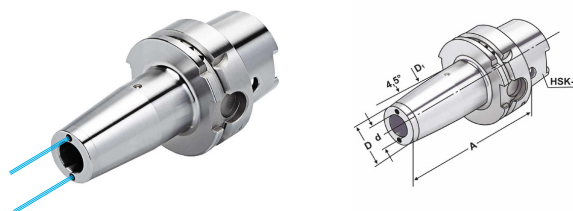

Název	Kužel	d	D	D ₁	l ₁	l ₂	A	G 2,5 25.000 min ⁻¹
HSK100A.80.TK4.05	HSK100A	5	16	22	20	5	80	•
HSK100A.120.TK4.05	HSK100A	5	16	22	20	5	120	•
HSK100A.85.TK4.06	HSK100A	6	21	27	36	10	85	•
HSK100A.120.TK4.06	HSK100A	6	21	27	36	10	120	•
HSK100A.85.TK4.08	HSK100A	8	21	27	36	10	85	•
HSK100A.120.TK4.08	HSK100A	8	21	27	36	10	120	•
HSK100A.90.TK4.10	HSK100A	10	24	32	42	10	90	•
HSK100A.120.TK4.10	HSK100A	10	24	32	42	10	120	•
HSK100A.95.TK4.12	HSK100A	12	24	32	47	10	95	•
HSK100A.120.TK4.12	HSK100A	12	24	32	47	10	120	•
HSK100A.95.TK4.14	HSK100A	14	27	34	47	10	95	•
HSK100A.120.TK4.14	HSK100A	14	27	34	47	10	120	•
HSK100A.100.TK4.16	HSK100A	16	27	34	50	10	100	•
HSK100A.120.TK4.16	HSK100A	16	27	34	50	10	120	•
HSK100A.100.TK4.18	HSK100A	18	33	42	50	10	100	•
HSK100A.120.TK4.18	HSK100A	18	33	42	50	10	120	•
HSK100A.105.TK4.20	HSK100A	20	33	42	52	10	105	•
HSK100A.120.TK4.20	HSK100A	20	33	42	52	10	120	•
HSK100A.115.TK4.25	HSK100A	25	44	53	58	10	115	•
HSK100A.120.TK4.25	HSK100A	25	44	53	58	10	120	•
HSK100A.120.TK4.32	HSK100A	32	44	53	61	10	120	•

pro průměry stopek 3, 4 a 5 mm pouze pro karbidové nástroje

pro průměry stopek 3,4, a mm s tolerancí h4 a průměry stopek 6 až 32 s tolerancí h6 vhodné pro přístroje, které používají ohřev indukční, kontaktní a teplým vzduchem

l₁ = maximální upínací délka

l₂ = maximální délkové nastavení



Upínač tepelný 3°

pro upínání nástrojů se stopkou TK a HSS

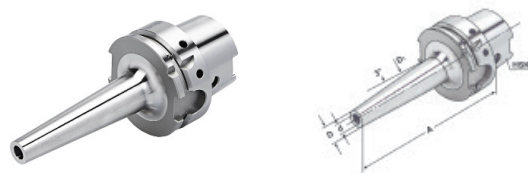

Název	Kužel	d	D	D ₁	l ₁	l ₂	A	G 2,5 25.000 min ⁻¹
HSK63A.80.T3.03	HSK63A	3	9	15,5	6	-	80	•
HSK63A.120.T3.03	HSK63A	3	9	19,5	6	-	120	•
HSK63A.80.T3.04	HSK63A	4	10	16,5	8	-	80	•
HSK63A.120.T3.04	HSK63A	4	10	20,5	8	-	120	•
HSK63A.160.T3.04	HSK63A	4	10	24	8	-	160	•
HSK63A.80.T3.05	HSK63A	5	11	17,5	10	-	80	•
HSK63A.120.T3.05	HSK63A	5	11	21,5	10	-	120	•
HSK63A.160.T3.05	HSK63A	5	11	25	10	-	160	•
HSK63A.80.T3.06	HSK63A	6	12	18,5	36	10	80	•
HSK63A.120.T3.06	HSK63A	6	12	22,5	36	10	120	•
HSK63A.160.T3.06	HSK63A	6	12	26,5	36	10	160	•
HSK63A.80.T3.08	HSK63A	8	14	20,5	36	10	80	•
HSK63A.120.T3.08	HSK63A	8	14	24,5	36	10	120	•
HSK63A.160.T3.08	HSK63A	8	14	28,5	36	10	160	•
HSK63A.85.T3.10	HSK63A	10	16	22,5	41	10	85	•
HSK63A.120.T3.10	HSK63A	10	16	26,5	41	10	120	•
HSK63A.160.T3.10	HSK63A	10	16	30,5	41	10	160	•
HSK63A.90.T3.12	HSK63A	12	18	24,5	46	10	90	•
HSK63A.120.T3.12	HSK63A	12	18	28,5	46	10	120	•
HSK63A.160.T3.12	HSK63A	12	18	32,5	46	10	160	•

pro průměry stopek 3, 4 a 5 mm pouze pro karbidové nástroje
 pro průměry stopek 3,4, a mm s tolerancí h4 a průměry stopek 6 až 32 s tolerancí h6
 vhodné pro přístroje, které používají ohřev indukční, kontaktní a teplým vzduchem

l₁ = maximální upínací délka

l₂ = maximální délkové nastavení



Upínač - polotovar

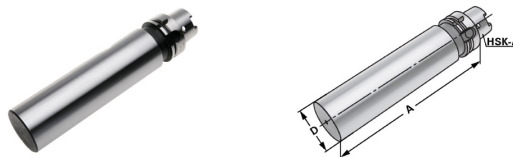

Název	Kužel	D	A
HSK63A.250.P.63	HSK63A	63,5	250
HSK63A.250.P.80	HSK63A	80	250
HSK100A.250.P.97	HSK100A	97,5	250

Kužel a příruba kalena a broušena. Těleso měkké pro další opracování.

Kontrolní trn

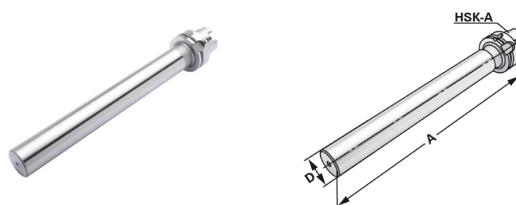

Název	Kužel	D	A	Max. odchylka soustřednosti
HSK63A.346.K.40	HSK63A	40	346	0,003
HSK100A0.329.K.50	HSK100A	50	329	0,003

dodávka: s kontrolním protokolem

Dřevěná kazeta pro kontrolní trn



Název	Kužel	Rozměr
Kazeta pro kontrolní trn	HSK 63 / 100	460x130x115



Příslušenství upínačů HSK-A



trubka chlazení

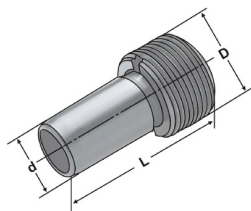

	D	d	L
HSK32S M10x1	M10X1	6	26,0
HSK40S M12x1	M12X1	8	29,5
HSK50S M16x1	M16X1	10	33,0
HSK63S M18x1	M18X1	12	34,5
HSK80S M20x1,5	M20X1,5	14	40,0
HSK100S M24x1,5	M24X1,5	16	44,0

klíč pro trubku chlazení

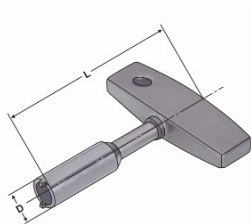

	D	L
HSK32K	8,5	115
HSK40K	10,5	115
HSK50K	14,5	115
HSK63K	16,5	136
HSK80K	18,5	136
HSK100K	22,0	136



Upínače VDI

DIN 69880 (VDI 3425) ISO 10889

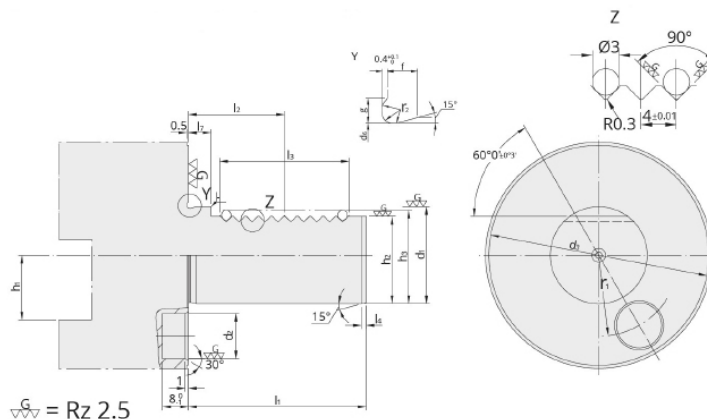

d_1	h_6	b	h_1 max	d_2	d_3	h_2 $\pm 0,1$	r $\pm 0,02$	l_1 max	l_2 $\pm 0,05$	l_3 max	l_4 max	l_5
16		42	12	8	40	15,0	14,5	32	12,7	16	2	3,5
20		52	16	10	50	18,0	18,0	40	21,7	24	2	7,0
25		60	16	10	58	23,5	21,0	48	21,7	24	2	7,0
30		70	20	14	68	27,0	25,0	55	29,7	40	2	7,0
40		85	25	14	83	36,0	32,0	63	29,7	40	3	7,0
50		100	32	16	98	45,0	37,0	78	35,7	48	3	8,0

materiál:

- legovaná ocel cementovaná do hl. $0.8 \pm 0.2\text{mm}$, kalená na $60 \pm 2\text{HRC}$
- s pevností v jádru min. 950 N/mm^2
- černěno a přesně broušeno

provedení:

- s vnitřním chlazením, případně se závitovým připojením pro externí chlazení

Přiřazení upínače k revolverové hlavě

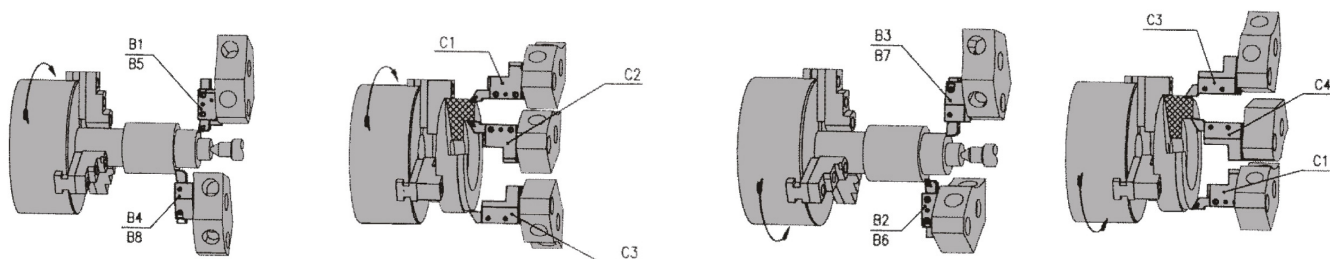

použití nástrojových upínačů s otáčkami vřetene ve směru hodinových ručiček

použití nástrojových upínačů s otáčkami vřetene proti směru hodinových ručiček



NA-U-VDI-1-001-03/23



NA-U-VDI-1-001-03/23



NA-U-VDI-1-002-03/23



NA-U-VDI-1-002-03/23



NA-U-VDI-1-003-03/23



NA-U-VDI-1-003-03/23



NA-U-VDI-1-004-03/23



NA-U-VDI-1-004-03/23



NA-U-VDI-1-005-03/23



NA-U-VDI-1-005-03/23



NA-U-VDI-1-006-03/23



NA-U-VDI-1-006-03/23



NA-U-VDI-2-001-03/23



NA-U-VDI-2-001-03/23



NA-U-VDI-2-002-03/23



NA-U-VDI-2-002-03/23



NA-U-VDI-2-003-03/23

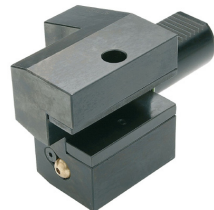

NA-U-VDI-2-003-03/23



NA-U-VDI-2-004-03/23



NA-U-VDI-2-004-03/23



NA-U-VDI-2-005-03/23



NA-U-VDI-2-005-03/23



NA-U-VDI-3-001-03/23



NA-U-VDI-3-001-03/23



NA-U-VDI-4-001-03/23



SK
DUAL SK
BT
DUAL BT
HSK
VDI
PRÍSLUŠENSTVÍ

NA-U-VDI-5-001-03/23



NA-U-VDI-6-001-03/23



NA-U-VDI-7-001-03/23



NA-U-VDI-8-001-03/23



NA-U-VDI-8-002-03/23



NA-U-VDI-8-002-03/23



NA-U-VDI-9-001-03/23



NA-U-VDI-9-002-03/23



NA-U-VDI-9-002-03/23



NA-U-VDI-10-001-03/23



NA-U-VDI-10-001-03/23



NA-U-VDI-10-002-03/23



NA-U-VDI-10-002-03/23



NA-U-VDI-10-003-03/23



NA-U-VDI-10-003-03/23



NA-U-VDI-10-004-03/23

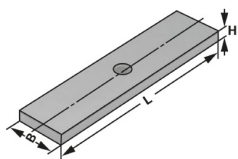

NA-U-VDI-10-004-03/23

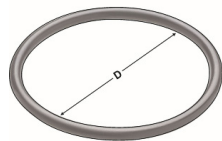

NA-U-VDI-10-004-03/23

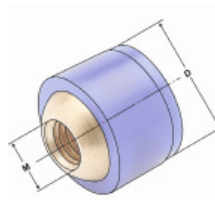

NA-U-VDI-10-004-03/23

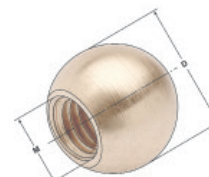

Upínač radiální B1 pravý, krátký

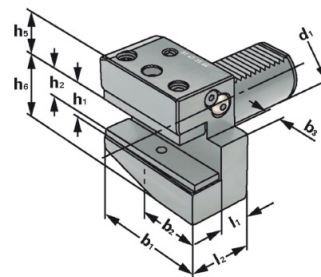

Název	d ₁	b ₁	b ₂	b ₃	l ₁	l ₂	h ₁	h ₂	h ₅	h ₆
B1-16x12x24	16	42	23	5	13	24	12	-	20	22
B1-20x16x30	20	55	30	7	16	30	16	12	25	30
B1-25x16x30	25	55	30	7	16	30	16	12	25	30
B1-30x20x40	30	70	35	10	22	40	24,5	20,5	23,5	42,5
B1-40x25x44	40	85	42,5	12,5	22	44	28	23	30	50
B1-50x32x55	50	100	50	16	30	55	33	26	35	60

provedení: s nastavitelnou tryskou chlazení nástroje a podložkou

Upínač radiální B1 pravý, krátký

pro nástroje s vnitřním chlazením

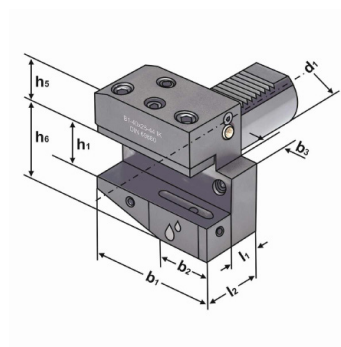

Název	d ₁	b ₁	b ₂	b ₃	l ₁	l ₂	h ₁	h ₅	h ₆
B1-30x20x40-IK	30	70	35	10	22	40	20	28	38
B1-40x25x44-IK	40	85	42,5	12,5	22	44	25	32,5	48
B1-50x32x55-IK	50	100	50	16	30	55	32	35	60

provedení: s nastavitelnou tryskou chlazení nástroje



Upínač radiální B2 levý, krátký

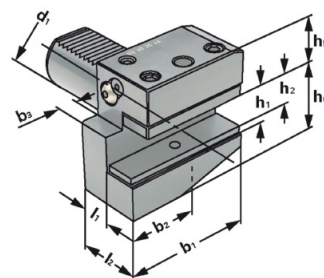

Název	d ₁	b ₁	b ₂	b ₃	l ₁	l ₂	h ₁	h ₂	h ₅	h ₆
B2-16x12x24	16	42	23	5	13	24	12	-	20	22
B2-20x16x30	20	55	30	7	16	30	16	12	25	30
B2-25x16x30	25	55	30	7	16	30	16	12	25	30
B2-30x20x40	30	70	35	10	22	40	24,5	20,5	23,5	42,5
B2-40x25x44	40	85	42,5	12,5	22	44	28	23	30	50
B2-50x32x55	50	100	50	16	30	55	33	26	35	60

provedení: s nastavitelnou tryskou chlazení nástroje a podložkou

Upínač radiální B2 levý, krátký

pro nástroje s vnitřním chlazením

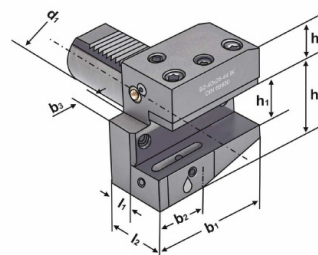

Název	d ₁	b ₁	b ₂	b ₃	l ₁	l ₂	h ₁	h ₅	h ₆
B2-30x20x40-IK	30	70	35	10	22	40	20	28	38
B2-40x25x44-IK	40	85	42,5	12,5	22	44	25	32,5	48
B2-50x32x55-IK	50	100	50	16	30	55	32	35	60

provedení: s nastavitelnou tryskou chlazení nástroje



Upínač radiální B3 pravý převrácený, krátký

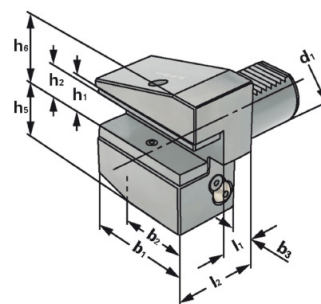

Název	d ₁	b ₁	b ₂	b ₃	l ₁	l ₂	h ₁	h ₂	h ₅	h ₆
B3-16x12x24	16	42	23	5	13	24	12	-	20	22
B3-20x16x30	20	55	30	7	16	30	16	12	25	30
B3-25x16x30	25	55	30	7	16	30	16	12	25	30
B3-30x20x40	30	70	35	10	22	40	25	20,5	30	43
B3-40x25x44	40	85	42,5	12,5	22	44	29	23	39,5	51
B3-50x32x55	50	100	50	16	30	55	34	26	49	61

provedení: s nastavitelnou tryskou chlazení nástroje a podložkou

Upínač radiální B3 pravý převrácený, krátký

pro nástroje s vnitřním chlazením

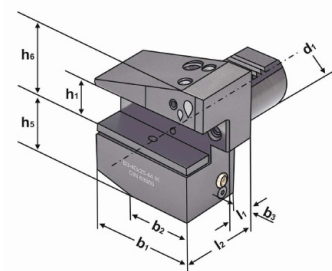

Název	d ₁	b ₁	b ₂	b ₃	l ₁	l ₂	h ₁	h ₅	h ₆
B3-30x20x40-IK	30	70	35	10	22	40	20	35	38
B3-40x25x44-IK	40	85	42,5	12,5	22	44	25	42,5	48
B3-50x32x55-IK	50	100	50	16	30	55	32	50	60

provedení: s nastavitelnou tryskou chlazení nástroje

Upínač radiální B4 levý převrácený, krátký

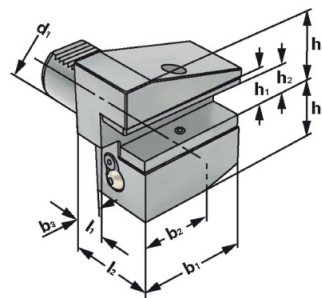

Název	d ₁	b ₁	b ₂	b ₃	l ₁	l ₂	h ₁	h ₂	h ₅	h ₆
B4-16x12x24	16	42	23	5	13	24	12	-	20	22
B4-20x16x30	20	55	30	7	16	30	16	12	35	30
B4-25x16x30	25	55	30	7	16	30	16	12	35	30
B4-30x20x40	30	70	35	10	22	40	25	20,5	30	42,5
B4-40x25x44	40	85	42,5	12,5	22	44	29	23	39,5	51
B4-50x32x55	50	100	50	16	30	55	34	26	49	61

provedení: s nastavitelnou tryskou chlazení nástroje a podložkou

Upínač radiální B4 levý převrácený, krátký

pro nástroje s vnitřním chlazením

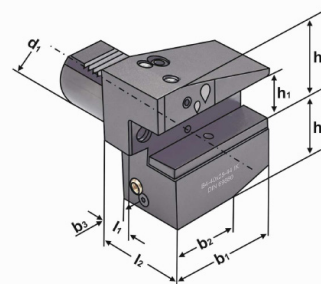

Název	d ₁	b ₁	b ₂	b ₃	l ₁	l ₂	h ₁	h ₅	h ₆
B4-30x20x40-IK	30	70	35	10	22	40	20	35	38
B4-40x25x44-IK	40	85	42,5	12,5	22	44	25	42,5	48
B4-50x32x55-IK	50	100	50	16	30	55	32	50	60

provedení: s nastavitelnou tryskou chlazení nástroje



Upínač radiální B5 pravý, dlouhý

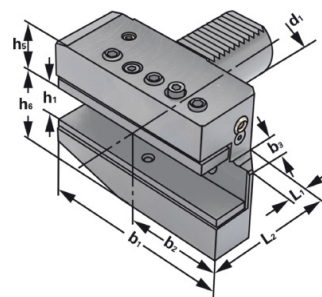

Název	d ₁	b ₁	b ₂	b ₃	L ₁	L ₂	h ₁	h ₅	h ₆
B5-16x12x24	16	58	39	5	13	24	12	22	20
B5-20x16x30	20	75	50	7	16	30	16	25	30
B5-25x16x30	25	75	50	7	16	30	16	25	30
B5-30x20x40	30	100	65	10	22	40	20	28	38
B5-40x25x44	40	118	75,5	12,5	22	44	25	32,5	48
B5-50x32x55	50	130	85	16	30	55	32	35	60

provedení: s nastavitelnou tryskou chlazení nástroje a podložkou

Upínač radiální B6 levý, dlouhý

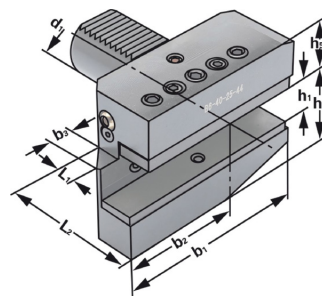

Název	d ₁	b ₁	b ₂	b ₃	L ₁	L ₂	h ₁	h ₅	h ₆
B6-16x12x24	16	58	39	5	13	24	12	22	20
B6-20x16x30	20	75	50	7	16	30	16	25	30
B6-25x16x30	25	75	50	7	16	30	16	25	30
B6-30x20x40	30	100	65	10	22	40	20	28	38
B6-40x25x44	40	118	75,5	12,5	22	44	25	32,5	48
B6-50x32x55	50	130	80	16	30	55	32	35	60

provedení: s nastavitelnou tryskou chlazení nástroje



Upínač radiální B7 pravý převrácený, dlouhý

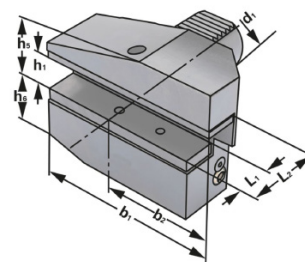

Název	d ₁	b ₁	b ₂	b ₃	l ₁	l ₂	h ₁	h ₅	h ₆
B7-16x12x24	16	58	39	5	13	24	12	20	22
B7-20x16x30	20	75	50	7	16	30	16	30	25
B7-25x16x30	25	75	50	7	16	30	16	30	25
B7-30x20x40	30	100	65	10	22	40	20	42	30
B7-40x25x44	40	118	75,5	12,5	22	44	25	48	42,5
B7-50x32x55	50	130	80	16	30	55	32	60	50

provedení: s nastavitelnou tryskou chlazení nástroje a podložkou

Upínač radiální B8 levý převrácený, dlouhý

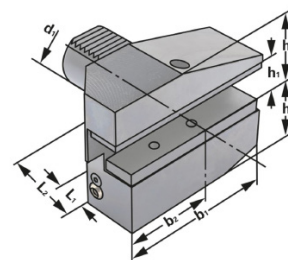

Název	d ₁	b ₁	b ₂	b ₃	L ₁	L ₂	h ₁	h ₅	h ₆
B8-16x12x24	16	58	39	5	13	24	12	20	22
B8-20x16x30	20	75	50	7	16	30	16	30	25
B8-25x16x30	25	75	50	7	16	30	16	30	25
B8-30x20x40	30	100	65	10	22	40	20	38	35
B8-40x25x44	40	118	75,5	12,5	22	44	25	48	42,5
B8-50x32x55	50	130	80	16	30	55	32	60	50

provedení: s nastavitelnou tryskou chlazení nástroje a podložkou



Upínač axiální C1 pravý

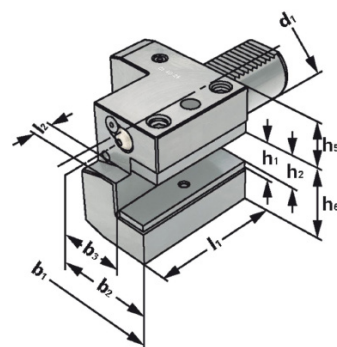

Název	d ₁	b ₁	b ₂	b ₃	L ₁	L ₂	h ₁	h ₂	h ₅	h ₆
C1-16x12	16	43	24	13	44	5	12	10	20	22
C1-20x16	20	52	27	13	50	7	16	12	25	30
C1-25x16	25	58	33	19	55	7	16	12	25	30
C1-30x20	30	70	35	17	70	10	20	16	28	38
C1-40x25	40	85	42,5	21	85	12,5	25	20	32,5	48
C1-50x32	50	100	50	26	100	16	32	25	35	60

provedení: s nastavitelnou tryskou chlazení nástroje a podložkou

Upínač axiální C1 pravý

pro nástroje s vnitřním chlazením

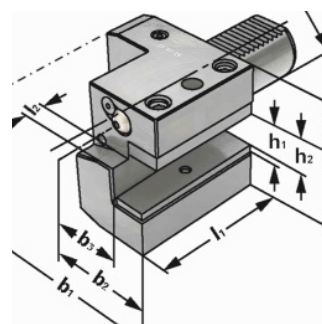

Název	d ₁	b ₁	b ₂	b ₃	l ₁	l ₂	h ₁	h ₅	h ₆
C1-30x20-IK	30	76	49	31	70	10	20	24	42
C1-40x25-IK	40	90	55	33	85	12,5	25	32,5	48
C1-50x32-IK	50	105	62	38	100	16	32	35	60

provedení: s nastavitelnou tryskou chlazení nástroje



Upínač axiální C2 levý

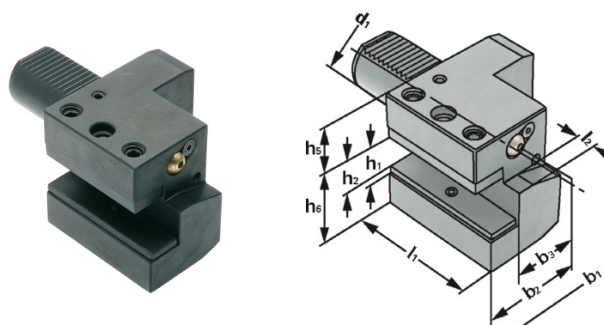

Název	d ₁	b ₁	b ₂	b ₃	l ₁	l ₂	h ₁	h ₂	h ₅	h ₆
C2-16x12	16	43	24	13	44	5	12	-	20	22
C2-20x16	20	65	40	26	50	7	16	12	25	30
C2-25x16	25	58	33	26	55	7	16	12	20	30
C2-30x20	30	76	41	23	70	10	20	16	28	38
C2-40x25	40	90	47,5	25,5	85	12,5	25	20	32,5	48
C2-50x32	50	105	55	30,5	100	16	32	25	35	60

provedení: s nastavitelnou tryskou chlazení nástroje a podložkou

Upínač axiální C2 levý

pro nástroje s vnitřním chlazením

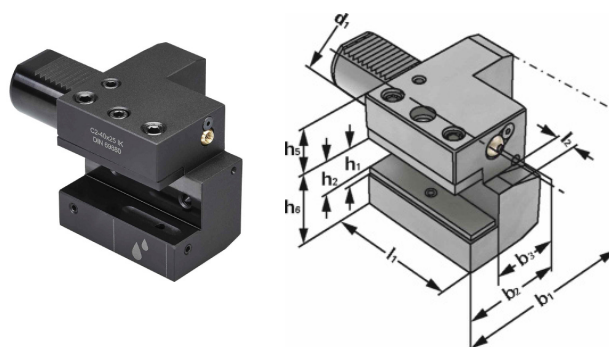

Název	d ₁	b ₁	b ₂	b ₃	l ₁	l ₂	h ₁	h ₅	h ₆
C2-30x20-IK	30	76	49	31	70	10	20	24	42
C2-40x25-IK	40	90	55	33	85	12,5	25	32,5	48
C2-50x32-IK	50	105	62	38	100	16	32	35	60

provedení: s nastavitelnou tryskou chlazení nástroje



Upínač axiální C3 pravý převrácený, krátký

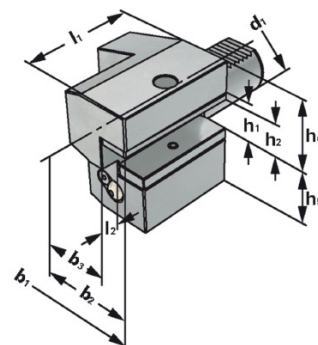

Název	d ₁	b ₁	b ₂	b ₃	l ₁	l ₂	h ₁	h ₂	h ₅	h ₆
C3-16x12	16	43	24	13	44	5	12	10	20	22
C3-20x16	20	52	27	13	55	7	16	12	30	25
C3-25x16	25	58	33	19	55	7	16	12	30	25
C3-30x20	30	70	35	17	70	10	20	16	38	35
C3-40x25	40	85	42,5	21	85	12,5	25	20	48	42,5
C3-50x32	50	100	50	26	100	16	32	25	60	50

provedení: s nastavitelnou tryskou chlazení nástroje a podložkou

Upínač axiální C3 pravý převrácený, krátký

pro nástroje s vnitřním chlazením

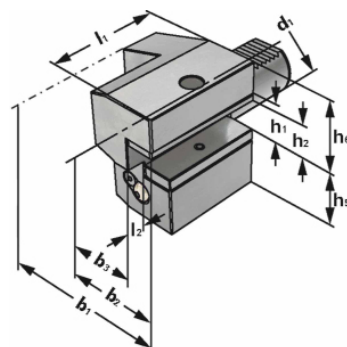

Název	d ₁	b ₁	b ₂	b ₃	l ₁	l ₂	h ₁	h ₅	h ₆
C3-30x20-IK	30	70	35	17	70	10	20	38	35
C3-40x25-IK	40	85	42,5	21	85	12,5	25	48	42,5
C3-50x32-IK	50	100	50	26	100	16	32	60	50

provedení: s nastavitelnou tryskou chlazení nástroje



Upínač axiální C4 levý převrácený, krátký

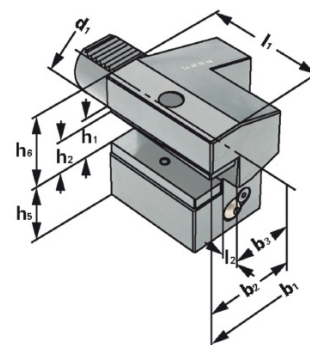

Název	d ₁	b ₁	b ₂	b ₃	l ₁	l ₂	h ₁	h ₂	h ₅	h ₆
C4-16x12	16	43	24	13	44	5	12	10	22	22
C4-20x16	20	65	40	26	50	7	16	12	30	25
C4-25x16	25	58	33	19	55	7	16	12	30	25
C4-30x20	30	76	41	23	70	10	20	16	38	35
C4-40x25	40	90	47,5	25,5	85	12,5	25	20	48	42,5
C4-50x32	50	105	55	30,5	100	16	32	25	60	50

provedení: s nastavitelnou tryskou chlazení nástroje a podložkou

Upínač axiální C4 levý převrácený, krátký

pro nástroje s vnitřním chlazením

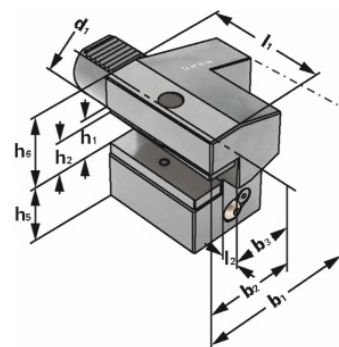

Název	d ₁	b ₁	b ₂	b ₃	l ₁	l ₂	h ₁	h ₅	h ₆
C4-30x20-IK	30	70	35	17	70	10	20	38	35
C4-40x25-IK	40	85	42,5	21	85	12,5	25	48	42,5
C4-50x32-IK	50	100	50	26	100	16	32	60	50

provedení: s nastavitelnou tryskou chlazení nástroje



Upínač D1

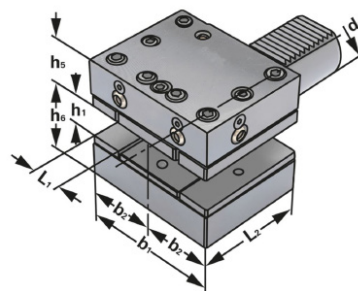

Název	d ₁	b ₁	b ₂	L ₁	L ₂	h ₁	h ₅	h ₆
D1-30x20x60	30	76	41	18	60	20	28	38
D1-40x25x72	40	90	47,5	22	72	25	32,5	48
D1-50x32x85	50	105	55	24,5	85	32	35	60

provedení: s nastavitelnou tryskou chlazení nástroje a podložkou

Upínač D2 převrácený

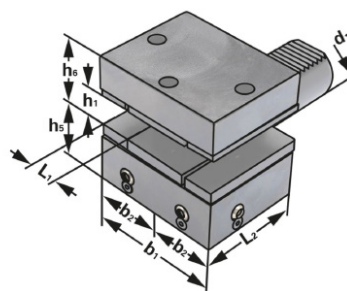

Název	d ₁	b ₁	b ₂	L ₁	L ₂	h ₁	h ₅	h ₆
D2-30x20x60	30	76	41	18	60	20	35	38
D2-40x25x72	40	90	47,5	22	72	25	42,5	48
D2-50x32x85	50	105	55	24,5	85	32	50	60

provedení: s nastavitelnou tryskou chlazení nástroje a podložkou



Upínač pro upichovací/zapichovací planžety, pravý

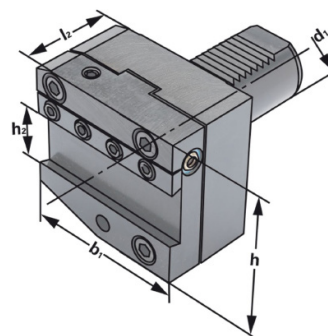

Název	d ₁	b ₁	h	l ₂	h ₂
AR-30x26	30	70	70	50	26
AR-40x32	40	85	80	50	32
AR-50x32	50	100	80	50	32

provedení: s nastavitelnou tryskou chlazení nástroje

Upínač pro upichovací/zapichovací planžety, levý

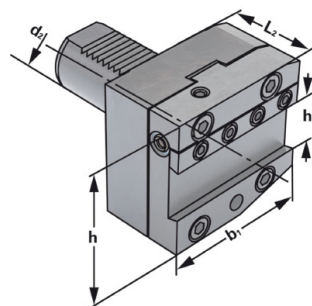

Název	d ₁	b ₁	h	L ₂	h ₂
AL-30x26	30	70	70	50	26
AL-40x32	40	85	80	50	32
AL-50x32	50	100	80	50	32

provedení: s nastavitelnou tryskou chlazení nástroje

Upínač E4 pro kleštiny ER



DIN 6499 (ISO 15488)

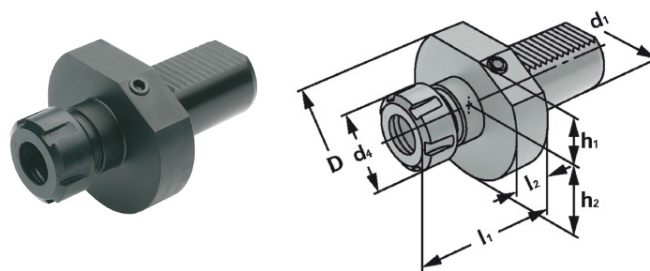

Název	d ₁	Rozsah	D	d ₄	h ₁	h ₂	l ₁	l ₂
E4-16x16	16	1 – 10 (ER 16)	40	28	18	18	40	13
E4-20x16	20	1 – 10 (ER 16)	50	28	25	23	42	18
E4-20x25	20	2 – 16 (ER 25)	50	42	25	23	46	18
E4-25x25	25	2 – 16 (ER 25)	58	42	25	25	55	18
E4-25x32	25	2 – 20 (ER 32)	58	50	25	25	55	18
E4-30x25	30	2 – 16 (ER 25)	68	42	28	30	57	22
E4-30x32	30	2 – 20 (ER 32)	68	50	28	30	75	22
E4-30x40	30	3 – 26 (ER 40)	68	63	28	30	75	22
E4-40x25	40	2 – 16 (ER 25)	83	42	32,5	41,5	75	22
E4-40x32	40	2 – 20 (ER 32)	83	50	32,5	41,5	75	22
E4-40x40	40	3 – 26 (ER 40)	83	63	32,5	41,5	75	22
E4-50x40	50	3 – 26 (ER 40)	98	63	35	49	75	30

dodávka: s vyváženou upínací maticí, bez montážního klíče



Upínač E1 pro vrtáky

s vyměnitelnými destičkami

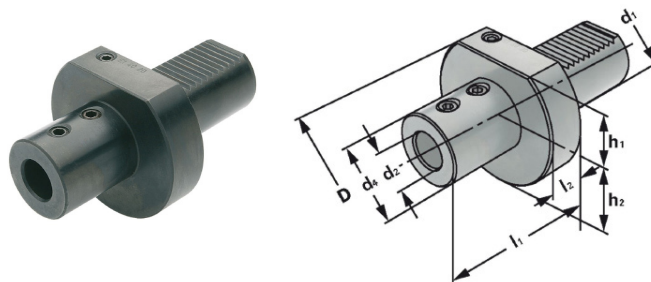

Název	d ₁	d ₂	D	d ₄	h ₁	h ₂	l ₁	l ₂
E1-20x16	20	16	50	40	22	22	67	18
E1-20x20	20	20	50	40	22	22	67	18
E1-20x25	20	25	50	45	22	22	71	18
E1-25x16	25	16	58	40	25	25	67	18
E1-25x20	25	20	58	40	25	25	67	18
E1-25x25	25	25	58	45	25	25	71	18
E1-25x32	25	32	58	58	25	25	78	-
E1-30x16	30	16	68	36	28	30	64	22
E1-30x20	30	20	68	40	28	30	67	22
E1-30x25	30	25	68	45	28	30	71	22
E1-30x32	30	32	68	52	28	30	75	22
E1-30x40	30	40	68	60	28	30	95	22
E1-40x16	40	16	83	36	32,5	41,5	64	22
E1-40x20	40	20	83	40	32,5	41,5	67	22
E1-40x25	40	25	83	45	32,5	41,5	75	22
E1-40x32	40	32	83	52	32,5	41,5	75	22
E1-40x40	40	40	83	65	32,5	41,5	90	22
E1-50x16	50	16	98	40	35	49	66	30
E1-50x20	50	20	98	40	35	49	66	30
E1-50x25	50	25	98	45	35	49	80	30
E1-50x32	50	32	98	52	35	49	80	30
E1-50x40	50	40	98	65	35	49	90	30
E1-50x50	50	50	98	75	35	49	100	30



Upínač E2 pro vnitřní soustružnické nože

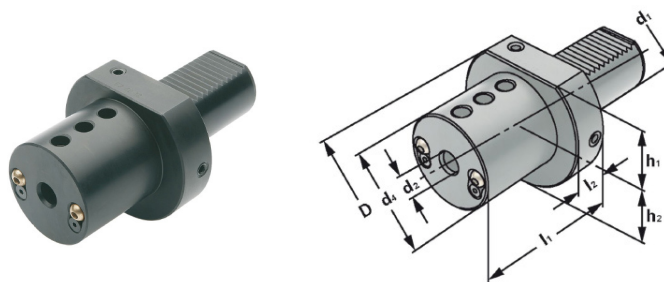

Název	d ₁	d ₂	D	d ₄	h ₁	h ₂	l ₁	l ₂
E2-16x06	16	6	40	32	18	20	44	13
E2-16x08	16	8	40	32	18	20	44	13
E2-16x10	16	10	40	32	18	20	44	13
E2-16x12	16	12	40	32	18	20	44	13
E2-16x16	16	16	40	32	18	20	44	13
E2-20x08	20	8	50	40	23	25	50	18
E2-20x10	20	10	50	40	23	25	50	18
E2-20x12	20	12	50	40	23	25	50	18
E2-20x16	20	16	50	40	23	25	50	18
E2-20x20	20	20	50	40	23	25	50	18
E2-25x08	25	8	58	40	25	25	50	18
E2-25x10	25	10	58	40	25	25	50	18
E2-25x12	25	12	58	40	25	25	50	18
E2-25x16	25	16	58	40	25	25	50	18
E2-25x20	25	20	58	58	25	25	50	-
E2-25x25	25	25	58	58	25	25	60	-
E2-30x08	30	8	68	55	28	30	60	22
E2-30x10	30	10	68	55	28	30	60	22
E2-30x12	30	12	68	55	28	30	60	22
E2-30x16	30	16	68	55	28	30	60	22
E2-30x20	30	20	68	55	28	30	60	22
E2-30x25	30	25	68	55	28	30	60	22
E2-30x32	30	32	68	68	28	30	75	-
E2-40x08	40	8	83	55	32,5	41,5	75	22
E2-40x10	40	10	83	55	32,5	41,5	75	22
E2-40x12	40	12	83	55	32,5	41,5	75	22
E2-40x16	40	16	83	55	32,5	41,5	75	22
E2-40x20	40	20	83	55	32,5	41,5	75	22
E2-40x25	40	25	83	55	32,5	41,5	75	22
E2-40x32	40	32	83	83	32,5	41,5	75	-
E2-40x40	40	40	83	83	32,5	41,5	90	-
E2-50x12	50	12	98	68	35	49	90	30
E2-50x16	50	16	98	68	35	49	90	30
E2-50x20	50	20	98	68	35	49	90	30
E2-50x25	50	25	98	68	35	49	90	30
E2-50x32	50	32	98	68	35	49	90	30
E2-50x40	50	40	98	98	35	49	90	-
E2-50x50	50	50	98	98	35	49	100	-

provedení: s nastavitelnými tryskami chlazení nástroje



Hydro upínač



pro upínací stopky DIN 1835 A+B+E a DIN 6535 HA+HB+HE

(větší než průměr 20 mm pouze s redukčním pouzdem)

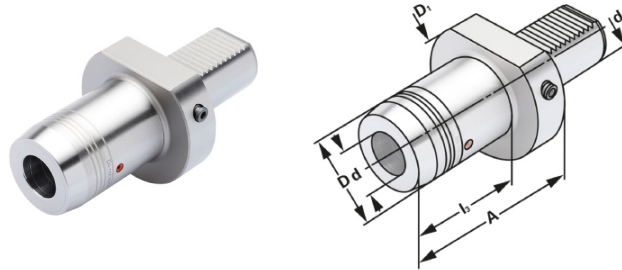

Název	d ₁	d	D	A	l ₃	D ₁
VDI30.H.12	30	12	32	54	38	68
VDI30.H.20	30	20	42	89	73	68
VDI40.H.12	40	12	32	60	38	83
VDI40.H.20	40	20	42	95	73	83

dodávka s montážním klíčem



Upínač F1 pro nástroje s Morse stopkou



DIN 228-1 Form B

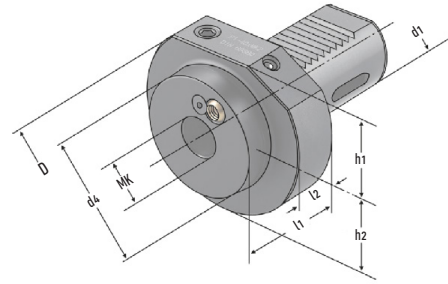

Název	d ₁	MK	D	d ₄	h ₁	h ₂	l ₁	l ₂
F1-16xMK1	16	1	40	32	18	18	32	13
F1-20xMK1	20	1	50	-	22	23	23	-
F1-20xMK2	20	2	50	40	22	23	90	-
F1-25xMK1	25	1	58	-	25	25	23	-
F1-25xMK2	25	2	58	-	25	25	27	-
F1-30xMK1	30	1	68	-	28	30	27	-
F1-30xMK2	30	2	68	-	28	30	27	-
F1-30xMK3	30	3	68	58	28	30	75	22
F1-40xMK2	40	2	83	55	32,5	50,5	36	22
F1-40xMK3	40	3	83	55	32,5	50,5	36	22
F1-40xMK4	40	4	83	68	32,5	50,5	80	22
F1-50xMK2	50	2	98	55	35	49	36	30
F1-50xMK3	50	3	98	58	35	49	36	30
F1-50xMK4	50	4	98	68	35	49	50	30
F1-50xMK5	50	5	98	98	35	49	168	-

provedení: s nastavitelnými tryskami chlazení nástroje



Upínač - polotovár A1

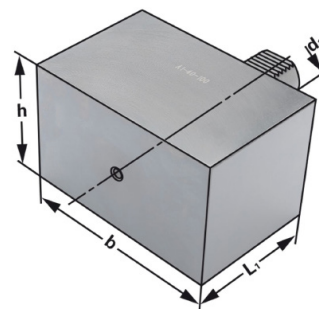

Název	d_1	L_1	h	b
A1-16	16	44	44	78
A1-20	20	65	60	100
A1-25	25	75	60	100
A1-30	30	85	76	130
A1-40	40	100	96	151
A1-50	50	125	120	160

Upínač - polotovár A2

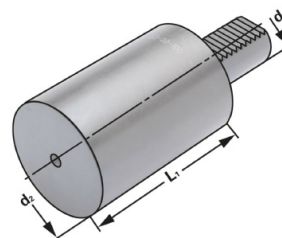

Název	d_1	d_2	L_2
A2-16x60	16	40	60
A2-20x70	20	50	70
A2-25x80	25	58	80
A2-25x200	25	58	200
A2-30x100	30	68	100
A2-30x240	30	68	240
A2-40x120	40	83	120
A2-40x320	40	83	320
A2-50x135	50	98	135
A2-50x400	50	98	400

Těleso pro další opracování



Závitořezná hlava s délkovou kompenzací

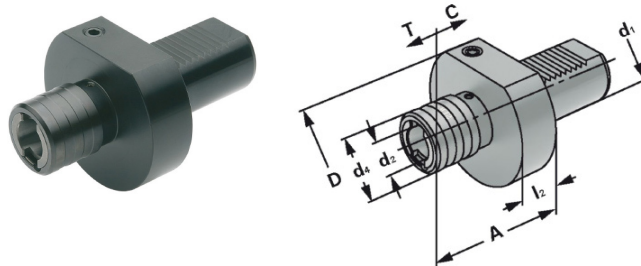

Název	d ₁	Rozsah	D	d ₂	d ₄	A	T	C	Upínač závítníku
VDI20.314.Z.1.DK	20	M3 - M14	50	19	38	67	7	7	UZB1/UZS1
VDI25.314.Z.1.DK	25	M3 - M14	58	19	38	55	7	7	UZB1/UZS1
VDI30.314.Z.1.DK	30	M3 - M14	68	19	36	58	7	7	UZB1/UZS1
VDI30.522.Z.2.DK	30	M5 - M22	68	31	53	81	12	12	UZB2/UZS2
VDI40.314.Z.1.DK	40	M3 - M14	83	19	36	58	7	7	UZB1/UZS1
VDI40.522.Z.2.DK	40	M5 - M22	83	31	53	81	12	12	UZB2/UZS2
VDI50.314.Z.1.DK	50	M3 - M14	98	19	36	56	7	7	UZB1/UZS1
VDI50.522.Z.2.DK	50	M5 - M22	98	31	53	80	12	12	UZB2/UZS2

Závitořezná hlava bez délkové kompenzace

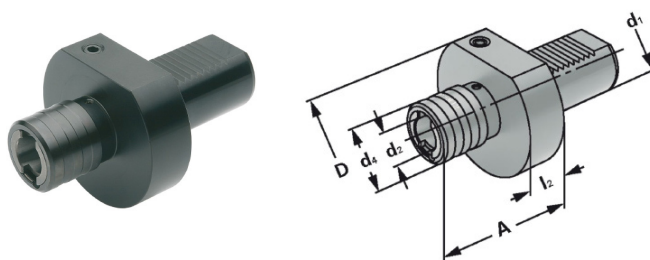

Název	d ₁	Rozsah	D	d ₂	d ₄	A	Upínač závítníku
VDI30.314.Z.1.BK	30	M3 - M14	68	19	36	55	UZB1/UZS1
VDI30.522.Z.2.BK	30	M5 - M22	68	31	53	77	UZB2/UZS2
VDI40.314.Z.1.BK	40	M3 - M14	83	19	36	55	UZB1/UZS1
VDI40.522.Z.2.BK	40	M5 - M22	83	31	53	77	UZB2/UZS2



Vrtací hlavička

s vnitřním chlazením

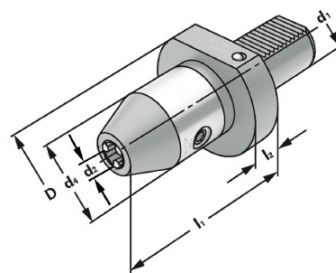

Název	d_1	Rozsah	d_4	D	l_1	l_2
VDI20.V.13	20	1 – 13	50	50	90	17
VDI30.V.13	30	1 – 13	50	68	93	22
VDI30.V.16	30	2,5 – 16	50	68	98	22
VDI40.V.13	40	1 – 13	50	83	93	22
VDI40.V.16	40	2,5 – 16	50	83	98	22
VDI50.V.13	50	1 – 13	50	98	101	30
VDI50.V.16	50	2,5 – 16	50	98	106	30

použití: pravé / levé otáčky
dodávka s montážním klíčem

Vrtací hlavička

s vnějším chlazením

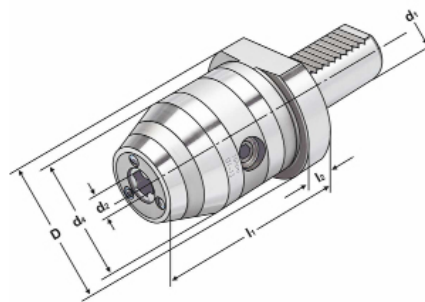

Název	d_1	Rozsah	d_4	D	l_1	l_2
VDI16.VK.10	16	1 - 13	57	40	87	5
VDI20.VK.10	20	1 - 13	57	50	87	5
VDI25.VK.13	25	1 – 13	57	58	87	15
VDI30.VK.13	30	1 – 13	57	68	87	22
VDI30.VK.16	30	2,5 – 16	57	68	92	22
VDI40.VK.13	40	1 – 13	57	83	87	22
VDI40.VK.16	40	2,5 – 16	57	83	92	22
VDI50.VK.16	50	2,5 – 16	57	98	96,9	20

použití: pravé / levé otáčky
dodávka s montážním klíčem

Redukční pouzdra pro upínače E2



pro upnutí vnitřních soustružnických nožů

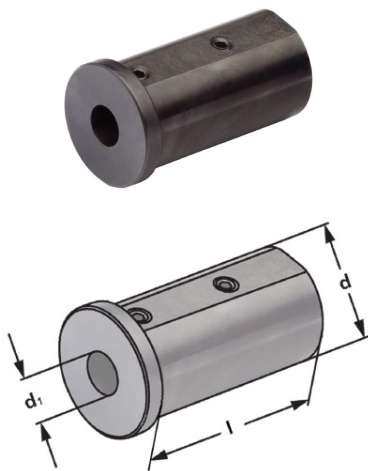

Provedení 1

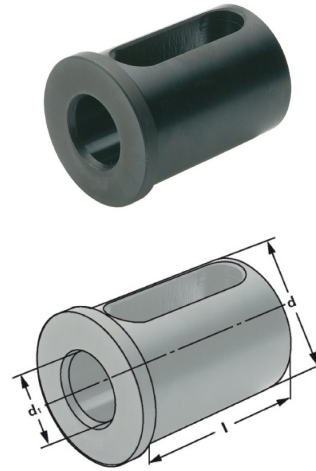

Provedení 2

Název	d	d ₁	L	Provedení
RE25 D6	25	6	46	1
RE25 D8	25	8	46	1
RE25 D10	25	10	46	1
RE25 D12	25	12	46	1
RE25 D14	25	14	46	1
RE25 D16	25	16	46	2
RE25 D18	25	18	46	2
RE25 D20	25	20	46	2
RE32 D6	32	6	55	1
RE32 D8	32	8	55	1
RE32 D10	32	10	55	1
RE32 D12	32	12	55	1
RE32 D14	32	14	55	1
RE32 D16	32	16	55	2
RE32 D18	32	18	55	2
RE32 D20	32	20	55	2
RE32 D25	32	25	55	2
RE40 D6	40	6	71	1
RE40 D8	40	8	71	1
RE40 D10	40	10	71	1
RE40 D12	40	12	71	1
RE40 D14	40	14	71	1
RE40 D16	40	16	71	2
RE40 D18	40	18	71	2
RE40 D20	40	20	71	2
RE40 D25	40	25	71	2
RE40 D32	40	32	71	2

vhodné pro nástroje s vnitřním chlazením (bez plošky na upínací stopce)



Ochranná zátka Z2 - ocelová

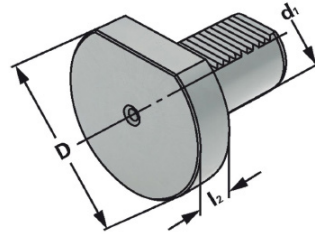
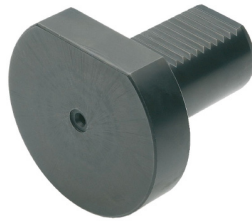

Název	d ₁	D	l ₂
Z2-16x13.S	16	40	13
Z2-20x16.S	20	50	16
Z2-25x16.S	25	58	16
Z2-30x16.S	30	68	16
Z2-40x20.S	40	83	20
Z2-50x20.S	50	98	20

Ochranná zátka Z2 - plastová

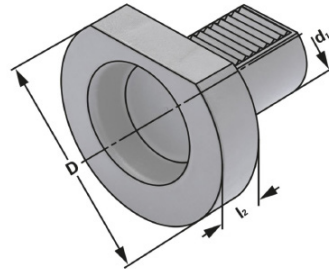

Název	d ₁	D	l ₂
Z2-16x13.P	16	40	13
Z2-20x16.P	20	50	16
Z2-25x16.P	25	58	16
Z2-30x16.P	30	68	16
Z2-40x20.P	40	83	20
Z2-50x20.P	50	98	20

Kontrolní trn

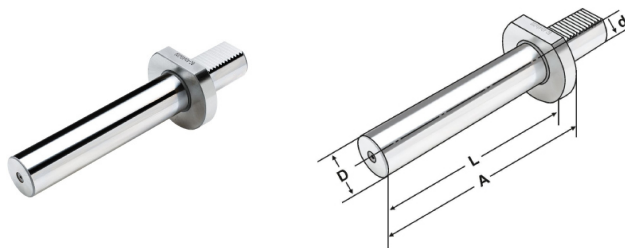

Název	d ₁	D	A	L	Max. odchylka soustřednosti
VDI16.120.K.30	16	30	120	107	0,003
VDI20.150.K.40	20	40	150	132	0,003
VDI25.150.K.40	25	40	150	135	0,003
VDI30.200.K.40	30	40	230	214	0,003
VDI40.200.K.40	40	40	200	184	0,003
VDI50.200.K.40	50	40	200	185	0,003

dodávka: s kontrolním protokolem

Dřevěná kazeta pro kontrolní trn



Název	Stopka	Rozměr
KAZETA PRO KONTROLNÍ TRN	VDI 16 / 20 / 25 / 25 / 30 / 40 / 50	460x130x115



Příslušenství



Podložka

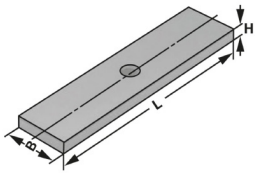

	B	H	L
VDI.14.P	14	4	54
VDI.13.5.P	13,5	4	49
VDI.16.P	16	4	69
VDI.20.P	20	5	84
VDI.23.P	23	7	99

„O“ kroužek pro utěsnění stopky VDI

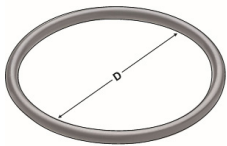

	D
VDI16.D.16	16
VDI20.D.20	20
VDI25.D.25	25
VDI30.D.30	30
VDI40.D.40	40
VDI50.D.50	50

Chladicí tryska pro upínače VDI

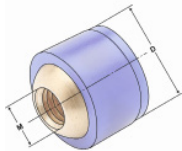

	D	M
D8.M3.P	8	-
D10.M4.P	10	M4
D12.M5.P	12	M5
D14.M6.P	14	M6

Mosazná chladicí tryska pro upínače VDI

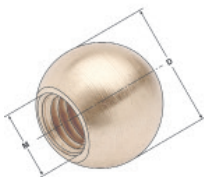

	D	M	Pro VDI
D8.M5.M	8	M5	16
D10.M6.M	10	M6	16 + 25 + 30 + 40
D12.M6.M	12	M6	50
D14.M8.M	14	M8	-

Mosazná chladicí trubička



	L	M	Ø
D3.M5.100.M	100	5	Ø 3 mm
D3.M6.100.M	100	6	Ø 3 mm



Příslušenství pro ISO, BT, HSK upínače

kleštiny



(NA-U-P-1-001-03/23 - NA-U-P-1-013-03/23)

klíče



(NA-U-P-2-001-03/23)

matice a těsnící kroužky



(NA-U-P-3-001-03/23)

šrouby



(NA-U-P-4-001-03/23)

unášecí kameny



(NA-U-P-5-001-03/23)

sondy



(NA-U-P-6-001-03/23)

tažné čepy



(NA-U-P-7-001-03/23 - NA-U-P-7-004-03/23)

upínače, vrtací hlavičky a další



(NA-U-P-8-001-03/23 - NA-U-P-8-007-03/23)

Kleština ER

ISO 15488 B (DIN 6499 B)

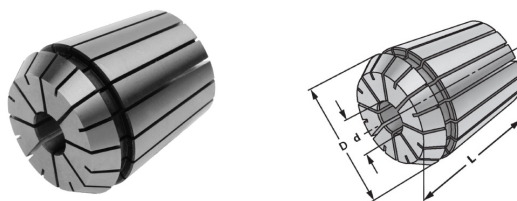

obvodové házení $\leq 0,015$

Název	D	L	Upínací rozsah	Vzestupně po
ER11 D..	11,5	18	1 - 7	0,5
ER16 D..	17	27	1 - 10	1
ER20 D..	21	31,5	2 - 13	1
ER25 D..	26	34	2 - 16	1
ER32 D..	33	40	2 - 20	1
ER40D ..	41	46	3 - 26	1



obvodové házení $\leq 0,015$

Název	Počet kleštín v sadě	Upínací rozsah
SADA ER11	(1-7) 13 ks	1-1,5-2-2,5-3-3,5-4-4,5-5-5,5-6-6,5-7
SADA ER16	(1-10) 10 ks	1-2-3-4-5-6-7-8-9-10
SADA ER20	(2-13) 12 ks	2-3-4-5-6-7-8-9-10-11-12-13
SADA ER25	(2-16) 15 ks	2-3-4-5-6-7-8-9-10-11-12-13-14-15-16
SADA ER32	(3-20) 18 ks	3-4-5-6-7-8-9-10-11-12-13-14-15-16-17-18-19-20



Kleština ER utěsněná

ISO 15488 B (DIN 6499 B)

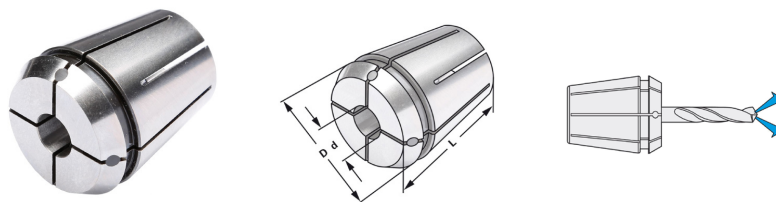

obvodové házení $\leq 0,015$

Název	D	L	Upínací rozsah	Vzestupně po
ER16T D..	17	27	3 - 10	1
ER20T D..	21	31,5	3 - 13	1
ER25T D..	26	34	3 - 16	1
ER32T D..	33	40	3 - 20	1
ER40T D..	41	46	3 - 26	1



obvodové házení $\leq 0,015$

Název	Počet kleštín v sadě	Upínací rozsah
SADA ER16T	(3-10) 8 ks	3-4-5-6-7-8-9-10
SADA ER20T	(3-13) 11 ks	3-4-5-6-7-8-9-10-11-12-13
SADA ER25T	(3-16) 14 ks	3-4-5-6-7-8-9-10-11-12-13-14-15-16
SADA ER32T	(3-20) 15 ks	3-4-5-6-7-8-9-10-11-12-14-15-16-18-20
SADA ER40T	(4-26) 16 ks	4-5-6-7-8-9-10-11-12-14-16-18-20-22-24-26

poznámka: pouze jmenovitý (nominální) rozměr stopky může být upínán do utěsněné kleštiny (použitelné do 21 barů)
pro dosažení maximálního utěsnění musí být stopka nástroje upnuta po celé délce kleštiny



Kleština ER

ISO 15488 B (DIN6499 B)

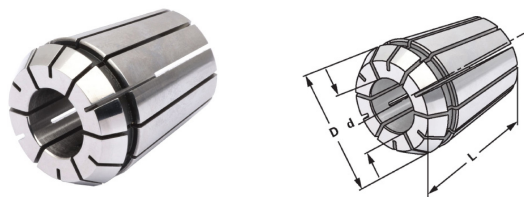

Obvodové házení $\leq 0,005$

Název	D	L	Upínací rozsah	Vzestupně po
ER11VP D..	11,5	18	1 - 7	0,5
ER16VP D..	17	27	1 - 10	1
ER20VP D..	21	31,5	2 - 13	1
ER25VP D..	26	34	2 - 16	1
ER32VP D..	33	40	2 - 20	1
ER40VP D..	41	46	3 - 26	1



Obvodové házení $\leq 0,005$

Název	Vzestupně po	Upínací rozsah
SADA ER11VP	(1-7) 13ks	1-1,5-2-2,5-3-3,5-4-4,5-5-5,5-6-6,5-7
SADA ER16VP	(1-10) 10ks	1-2-3-4-5-6-7-8-9-10
SADA ER20VP	(2-13) 12ks	2-3-4-5-6-7-8-9-10-11-12-13
SADA ER25VP	(2-16) 15ks	2-3-4-5-6-7-8-9-10-11-12-13-14-15-16
SADA ER32VP	(3-20) 18ks	3-4-5-6-7-8-9-10-11-12-13-14-15-16-17-18-19-20
SADA ER40VP	(4-26) 23ks	4-5-6-7-8-9-10-11-12-13-14-15-16-17-18-19-20-21-22-23-24-25-26



Kleština ER utěsněná s chladicími kanály u stopky



ISO 15488 B (DIN6499 B)

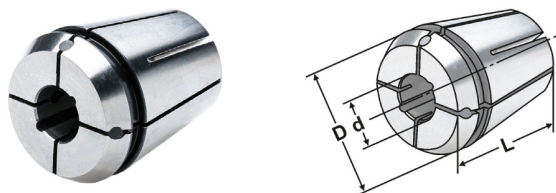

Obvodové házení $\leq 0,015$

Název	D	L	Upínací rozsah	Vzestupně po
ER16TKS D..	17	27	3 - 7	1
ER20TKS D..	21	31,5	4 - 9	1
ER25TKS D..	26	34	3 - 14	1
ER32TKS D..	33	40	3 - 20	1
ER40TKS D..	41	46	4 - 26	1

poznámka: pouze jmenovitý (nominální) rozměr stopky může být upínán do utěsněné kleštiny (použitelné do 21 barů)
pro dosažení maximálního utěsnění musí být stopka nástroje upnuta po celé délce kleštiny



Obvodové házení $\leq 0,015$

Název	Vzestupně po	Upínací rozsah
SADA ER16TKS	(3-7) 5ks	3-4-5-6-7
SADA ER20TKS	(4-9) 6ks	4-5-6-7-8-9
SADA ER25TKS	(3-14) 12ks	3-4-5-6-7-8-9-10-11-12-13-14
SADA ER32TKS	(3-20) 15ks	3-4-5-6-7-8-9-10-11-12-14-15-16-18-20
SADA ER40TKS	(4-26) 16ks	4-5-6-7-8-9-10-11-12-14-16-18-20-22-24-26



Kleština ER utěsněná do 120 barů



ISO 15488 B (DIN 6499 B)

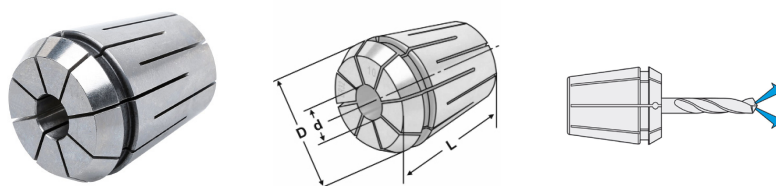

obvodové házení $\leq 0,015$

Název	D	L	Upínací rozsah	Vzestupně po
ER16TB D..	17	27	3 - 10	1
ER20TB D..	21	31,5	3 - 13	1
ER25TB D..	26	34	3 - 16	1
ER32TB D..	33	40	3 - 20	1
ER40TB D..	41	46	4 - 26	1



obvodové házení $\leq 0,015$

Název	Počet kleštín v sadě	Upínací rozsah
SADA ER16TB	(3-10) 8 ks	3-4-5-6-7-8-9-10
SADA ER20TB	(3-13) 11 ks	3-4-5-6-7-8-9-10-11-12-13
SADA ER25TB	(3-16) 14 ks	3-4-5-6-7-8-9-10-11-12-13-14-15-16
SADA ER32TB	(3-20) 15 ks	3-4-5-6-7-8-9-10-11-12-14-15-16-18-20
SADA ER40TB	(4-26) 16 ks	4-5-6-7-8-9-10-11-12-14-16-18-20-22-24-26

poznámka: pouze jmenovitý (nominální) rozměr stopky může být upínán do utěsněné kleštiny (použitelné do 120 barů)
pro dosažení maximálního utěsnění musí být stopka nástroje upnuta po celé délce kleštiny



Kleština ER utěsněná s chladicími kanály



ISO 15488 B (DIN 6499 B)

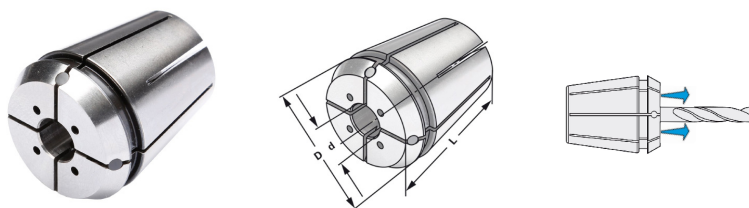

obvodové házení $\leq 0,015$

Název	D	L	Upínací rozsah	Vzestupně po
ER16TK D..	17	27	3 - 7	1
ER20TK D..	21	31,5	4 - 9	1
ER25TK D..	26	34	3 - 14	1
ER32TK D..	33	40	3 - 20	1
ER40TK D..	41	46	4 - 26	1



obvodové házení $\leq 0,015$

Název	Počet kleštín v sadě	Upínací rozsah
SADA ER16TK	(3-7) 5 ks	3-4-5-6-7
SADA ER20TK	(4-9) 6 ks	4-5-6-7-8-9
SADA ER25TK	(3-14) 12 ks	3-4-5-6-7-8-9-10-11-12-13-14
SADA ER32TK	(3-20) 15 ks	3-4-5-6-7-8-9-10-11-12-14-15-16-18-20
SADA ER40TK	(4-26) 16 ks	4-5-6-7-8-9-10-11-12-14-16-18-20-22-24-26

poznámka: pouze jmenovitý (nominální) rozměr stopky může být upínán do utěsněné kleštiny (použitelné do 21 barů)
pro dosažení maximálního utěsnění musí být stopka nástroje upnuta po celé délce kleštiny



Kleština ER pro upínání závitníků



ISO 15488 B (DIN 6499 B)



obvodové házení $\leq 0,015$

Název ER_Z	Název ER_ZK s chladicími kanály	Název ER_ZT utěsněná	Čtyřhran	D	L
ER16Z 3.5x2.7	ER16ZK 3.5x2.7	ER16ZT 3.5x2.7	2,7	16,8	27,5
ER16Z 4x3	ER16ZK 4x3	ER16ZT 4x3	3	16,8	27,5
ER16Z 4.5x3.4	ER16ZK 4.5x3.4	ER16ZT 4.5x3.4	3,4	16,8	27,5
ER16Z 6x4.9	ER16ZK 6x4.9	ER16ZT 6x4.9	4,9	16,8	27,5
ER16Z 7x5.5	ER16ZK 7x5.5	ER16ZT 7x5.5	5,5	16,8	27,5
ER16Z 8x6.2	ER16ZK 8x6.2	ER16ZT 8x6.2	6,2	16,8	27,5



obvodové házení $\leq 0,015$

Název	Počet kleštín v sadě	Upínací rozsah
SADA ER16Z	(3,5 - 8) 6 ks	3,5x2,7 - 4x3 - 4,5x3,4 - 6x4,9 - 7x5,5 - 8x6,2
SADA ER16ZK	(3,5 - 8) 6 ks	3,5x2,7 - 4x3 - 4,5x3,4 - 6x4,9 - 7x5,5 - 8x6,2
SADA ER16ZT	(3,5 - 8) 6 ks	3,5x2,7 - 4x3 - 4,5x3,4 - 6x4,9 - 7x5,5 - 8x6,2



Kleština ER pro upínání závitníků



ISO 15488 B (DIN 6499 B)



obvodové házení $\leq 0,015$

Název ER_Z	Název ER_ZK s chladicími kanály	Název ER_ZT utěsněná	Čtyřhran	D	L
ER20Z 3.5x2.7	ER20ZK 3.5x2.7	ER20ZT 3.5x2.7	2,7	20,8	31,5
ER20Z 4x3	ER20ZK 4x3	ER20ZT 4x3	3	20,8	31,5
ER20Z 4.5x3.4	ER20ZK 4.5x3.4	ER20ZT 4.5x3.4	3,4	20,8	31,5
ER20Z 6x4.9	ER20ZK 6x4.9	ER20ZT 6x4.9	4,9	20,8	31,5
ER20Z 7x5.5	ER20ZK 7x5.5	ER20ZT 7x5.5	5,5	20,8	31,5
ER20Z 8x6.2	ER20ZK 8x6.2	ER20ZT 8x6.2	6,2	20,8	31,5
ER20Z 9x7	ER20ZK 9x7	ER20ZT 9x7	7	20,8	31,5
ER20Z 10x8	ER20ZK 10x8	ER20ZT 10x8	8	20,8	31,5



obvodové házení $\leq 0,015$

Název	Počet kleštín v sadě	Upínací rozsah
SADA ER20Z	(3,5 - 10) 8 ks	3,5x2,7 - 4x3 - 4,5x3,4 - 6x4,9 - 7x5,5 - 8x6,2 - 9x7 - 10x8
SADA ER20ZK	(3,5 - 10) 8 ks	3,5x2,7 - 4x3 - 4,5x3,4 - 6x4,9 - 7x5,5 - 8x6,2 - 9x7 - 10x8
SADA ER20ZT	(3,5 - 10) 8 ks	3,5x2,7 - 4x3 - 4,5x3,4 - 6x4,9 - 7x5,5 - 8x6,2 - 9x7 - 10x8



Kleština ER pro upínání závitníků



ISO 15488 B (DIN 6499 B)



obvodové házení $\leq 0,015$

Název ER_Z	Název ER_ZK s chladicími kanály	Název ER_ZT utěsněná	Čtyřhran	D	L
ER25Z 3.5x2.7	ER25ZK 3.5x2.7	ER25ZT 3.5x2.7	2,7	26	34
ER25Z 4x3	ER25ZK 4x3	ER25ZT 4x3	3	26	34
ER25Z 4.5x3.4	ER25ZK 4.5x3.4	ER25ZT 4.5x3.4	3,4	26	34
ER25Z 6x4.9	ER25ZK 6x4.9	ER25ZT 6x4.9	4,9	26	34
ER25Z 7x5.5	ER25ZK 7x5.5	ER25ZT 7x5.5	5,5	26	34
ER25Z 8x6.2	ER25ZK 8x6.2	ER25ZT 8x6.2	6,2	26	34
ER25Z 9x7	ER25ZK 9x7	ER25ZT 9x7	7	26	34
ER25Z 10x8	ER25ZK 10x8	ER25ZT 10x8	8	26	34
ER25Z 11x9	ER25ZK 11x9	ER25ZT 11x9	9	26	34
ER25Z 12x9	ER25ZK 12x9	ER25ZT 12x9	9	26	34



obvodové házení $\leq 0,015$

Název	Počet kleštín v sadě	Upínací rozsah
SADA ER25Z	(3,5 - 12) 10 ks	3,5x2,7 - 4x3 - 4,5x3,4 - 6x4,9 - 7x5,5 - 8x6,2 - 9x7 - 10x8 - 11x9 - 12x9
SADA ER25ZK	(3,5 - 12) 10 ks	3,5x2,7 - 4x3 - 4,5x3,4 - 6x4,9 - 7x5,5 - 8x6,2 - 9x7 - 10x8 - 11x9 - 12x9
SADA ER25ZT	(3,5 - 12) 10 ks	3,5x2,7 - 4x3 - 4,5x3,4 - 6x4,9 - 7x5,5 - 8x6,2 - 9x7 - 10x8 - 11x9 - 12x9



Kleština ER pro upínání závitníků



ISO 15488 B (DIN 6499 B)



obvodové házení $\leq 0,015$

Název ER_Z	Název ER_ZK s chladicími kanály	Název ER_ZT utěsněná	Čtyřhran	D	L
ER32Z 4,5x3,4	ER32ZK 4,5x3,4	ER32ZT 4,5x3,4	3,4	33	40
ER32Z 6x4,9	ER32ZK 6x4,9	ER32ZT 6x4,9	4,9	33	40
ER32Z 7x5,5	ER32ZK 7x5,5	ER32ZT 7x5,5	5,5	33	40
ER32Z 8x6,2	ER32ZK 8x6,2	ER32ZT 8x6,2	6,2	33	40
ER32Z 9x7	ER32ZK 9x7	ER32ZT 9x7	7	33	40
ER32Z 10x8	ER32ZK 10x8	ER32ZT 10x8	8	33	40
ER32Z 11x9	ER32ZK 11x9	ER32ZT 11x9	9	33	40
ER32Z 12x9	ER32ZK 12x9	ER32ZT 12x9	9	33	40
ER32Z 14x11	ER32ZK 14x11	ER32ZT 14x11	11	33	40
ER32Z 16x12	ER32ZK 16x12	ER32ZT 16x12	12	33	40



obvodové házení $\leq 0,015$

Název	Počet kleštín v sadě	Upínací rozsah
SADA ER32Z	(4,5 - 16) 10 ks	4,5x3,4 - 6x4,9 - 7x5,5 - 8x6,2 - 9x7 - 10x8 - 11x9 - 12x9 - 14x11 - 16x12
SADA ER32ZK	(4,5 - 16) 10 ks	4,5x3,4 - 6x4,9 - 7x5,5 - 8x6,2 - 9x7 - 10x8 - 11x9 - 12x9 - 14x11 - 16x12
SADA ER32ZT	(4,5 - 16) 10 ks	4,5x3,4 - 6x4,9 - 7x5,5 - 8x6,2 - 9x7 - 10x8 - 11x9 - 12x9 - 14x11 - 16x12



Kleština ER pro upínání závitníků



ISO 15488 B (DIN 6499 B)



obvodové házení $\leq 0,015$

Název ER_Z	Název ER_ZK s chladicími kanály	Název ER_ZT utěsněná	Čtyřhran	D	L
ER40Z 6x4.9	ER40ZK 6x4.9	ER40ZT 6x4.9	4,9	40,8	46
ER40Z 7x5.5	ER40ZK 7x5.5	ER40ZT 7x5.5	5,5	40,8	46
ER40Z 8x6.2	ER40ZK 8x6.2	ER40ZT 8x6.2	6,2	40,8	46
ER40Z 9x7	ER40ZK 9x7	ER40ZT 9x7	7	40,8	46
ER40Z 10x8	ER40ZK 10x8	ER40ZT 10x8	8	40,8	46
ER40Z 11x9	ER40ZK 11x9	ER40ZT 11x9	9	40,8	46
ER40Z 12x9	ER40ZK 12x9	ER40ZT 12x9	9	40,8	46
ER40Z 14x11	ER40ZK 14x11	ER40ZT 14x11	11	40,8	46
ER40Z 16x12	ER40ZK 16x12	ER40ZT 16x12	12	40,8	46
ER40Z 18x14.5	ER40ZK 18x14.5	ER40ZT 18x14.5	14,5	40,8	46
ER40Z 20x16	ER40ZK 20x16	ER40ZT 20x16	16	40,8	46



obvodové házení $\leq 0,015$

Název	Počet kleštín v sadě	Upínací rozsah
SADA ER40Z	(6 -20) 11 ks	6x4,9 - 7x5,5 - 8x6,2 - 9x7 - 10x8 - 11x9 - 12x9 - 14x11 - 16x12 - 18x14,5 - 20x16
SADA ER40ZK	(6 -20) 11 ks	6x4,9 - 7x5,5 - 8x6,2 - 9x7 - 10x8 - 11x9 - 12x9 - 14x11 - 16x12 - 18x14,5 - 20x16
SADA ER40ZT	(6 -20) 11 ks	6x4,9 - 7x5,5 - 8x6,2 - 9x7 - 10x8 - 11x9 - 12x9 - 14x11 - 16x12 - 18x14,5 - 20x16



SK
DUAL SK
BT
DUAL BT
HSK
VDI
PŘÍSLUŠENSTVÍ

Kleština RS pro silové upínače

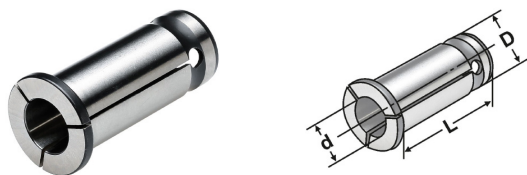

obvodové házení $\leq 0,005$

Název	d	D	L
RS20 D..	3, 4, 5, 6, 8, 10, 12, 14, 16	20	53
RS25 D..	6, 8, 10, 12, 14, 16, 18, 20	25	60
RS32 D..	6, 8, 10, 12, 14, 16, 18, 20, 25	32	73

poznámka: pro upínání hladké stopky v toleranci h6

Kleština RS_B pro silové upínače

pro vnitřní chlazení do 80 barů

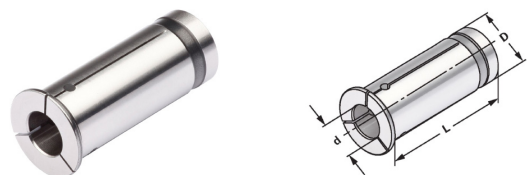

obvodové házení $\leq 0,005$

Název	d	D	L
RS20B D..	3, 4, 5, 6, 8, 10, 12, 14, 16	20	52,9
RS25B D..	3, 4, 5, 6, 8, 10, 12, 14, 16, 18, 20	25	52,5
RS32B D..	3, 4, 5, 6, 8, 10, 12, 14, 16, 18, 20, 25	32	66

poznámka: pro upínání hladké stopky v toleranci h6



Kleština RH_B pro hydro-upínače



pro vnitřní chlazení do 80 barů

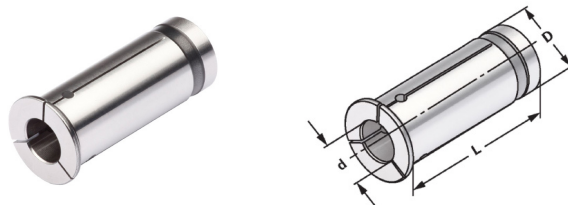

Obvodové házení $\leq 0,005$

Název	d	D	L
RH20TB D..	3, 4, 5, 6, 8, 10, 12, 14, 16	20	52,9
RH25TB D..	3, 4, 5, 6, 8, 10, 12, 14, 16, 18, 20	25	52,5
RH32TB D..	3, 4, 5, 6, 8, 10, 12, 14, 16, 18, 20, 25	32	66

poznámka: pro upínání hladké stoky v toleranci h6

Kleština RH pro hydro-upínače

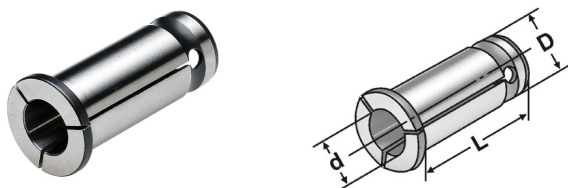

Obvodové házení $\leq 0,005$

Název	d	D	L
RH20 D..	3, 4, 5, 6, 8, 10, 12, 14, 16	20	53
RH25 D..	3, 4, 5, 6, 8, 10, 12, 14, 16, 18, 20	25	60
RH32 D..	6, 8, 10, 12, 14, 16, 18, 20, 25	32	64,6

poznámka: pro upínání hladké stoky v toleranci h6



klíče pro ER upínače

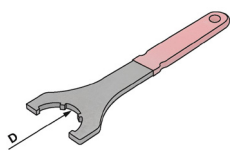

	D
ER16K	32
ER20K	35
ER25K	42
ER32K	50
ER40K	63

klíče pro ER upínače (pro matice se šestihranou hlavou)

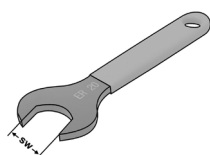

	SW
ER11K SW17	17
ER16K SW25	25
ER16K SW27	27
ER20K SW30	30

klíče pro ER upínače MINI

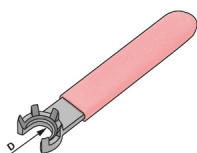

	D
ER11MK	16
ER16MK	22

klíče pro silové upínače

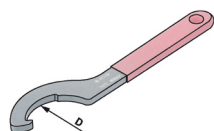

	D
RS20K	50
RS32K (pro velikost 25 a 32)	60

klíče pro vrtací hlavičky

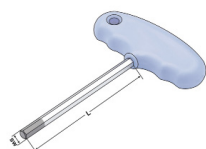

	SW
VT4	4
VT5	5
VT6	6

klíč pro nástrčné upínače

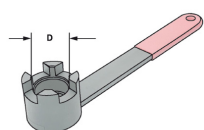

	D	M
NK16	16	M8
NK22	22	M10
NK27	27	M12
NK32	32	M16
NK40	40	M20
NK50	50	M24
NK60	60	M30

matice pro upínače ER standard

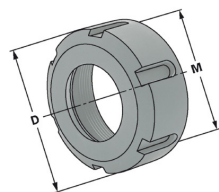

	D	M
KMER16	32	M22 x 1,5
KMER20	35	M25 x 1,5
KMER25	42	M32 x 1,5
KMER32	50	M40 x 1,5
KMER40	63	M50 x 1,5

matice pro upínače ER standard (se šestihranou hlavou)

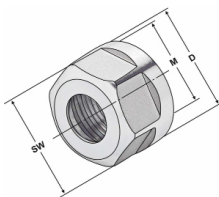

	SW	M
KMER11 SW17	17	M14 x 0,75
KMER16 SW25	25	M22 x 1,5
KMER20 SW30	30	M25 x 1,5

matice pro upínače ER Mini

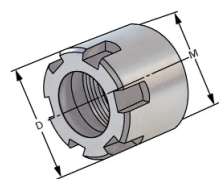

	D	M
KMER11 Mini	16	M13 x 0,75
KMER16 Mini	22	M19 x 1

matice ER pro těsnící kroužky TKER..

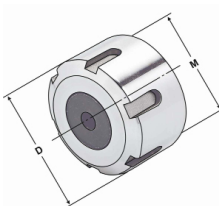

	d	M
KMTER16 SW25 (se šestihranou hlavou)	SW25	M22 x 1,5
KMTER20	35	M25 x 1,5
KMTER25	42	M32 x 1,5
KMTER32	50	M40 x 1,5
KMTER40	63	M50 x 1,5

poznámka: těsnící kroužky musí být objednány odděleně

těsnící kroužky pro matice KMTER..

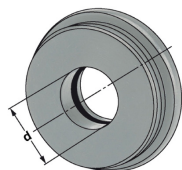

	d	vzestupně po
TKER16 D..	1 - 10	0,5
TKER20 D..	3 - 13	0,5
TKER25 D..	1 - 16	0,5
TKER32 D..	1 - 20	0,5
TKER40 D..	2 - 26	0,5

poznámka: vzestupně po 0,5 mm (+0,1/-0,4)
pro maximální tlak do 80barů

křížový šroub

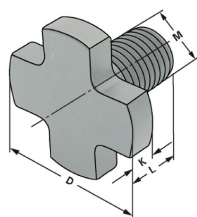

	průměr upínání	M	D	K	L
KS M8	16	M8	20	6	22
KS M10	22	M10	28	7	25
KS M12	27	M12	35	8	30
KS M16	32	M16	42	9	35
KS M20	40	M20	52	10	40
KS M24	50	M24	63	12	48
KS M30	60	M30	75	14	60

křížový šroub s chladicími kanály



	průměr upínání	M	D	K	L
KSK M8	16	M8	20	6	22
KSK M10	22	M10	28	7	25
KSK M12	27	M12	35	8	30
KSK M16	32	M16	42	9	35
KSK M20	40	M20	52	10	40
KSK M24	50	M24	63	12	48
KSK M30	60	M30	75	14	60

unašecí kámen pro nástrčné upínače

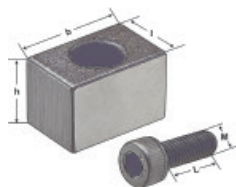

	l	b	h	M	L
UKN16	8	10	8	M3	12
UKN22	10	11	11	M4	12
UKN27	12	14,2	16	M4	16
UKN32	14	22	14	M5	14
UKN40	16	22,5	16	M5	14
UKN60	25,4	32,7	25,4	M12	25

unašecí kámen pro kombi upínače

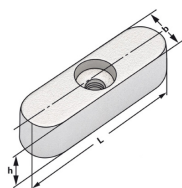

	h	b	L
UKK16	4	6	20
UKK22	6	6	25
UKK27	7	7	25
UKK32	7	8	28
UKK40	8	10	32

unašecí kroužek pro kombi upínače

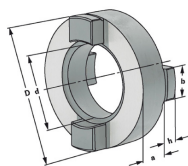

	d	D	a	b	h
UKR16	16	32	10	8	5
UKR22	22	40	12	10	5,6
UKR27	27	46	12	12	6,3
UKR32	32	55	14	14	7
UKR40	40	68	14	16	8

upínací šroub pro upínače Weldon DIN 1835-B

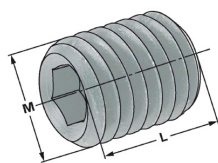

	M	L	pro průměr
SWM6	M6x1	10	6
SWM8	M8x1.25	10	8
SWM10	M10x1.5	12	10
SWM12	M12x1.75	16	12+14
SWM14	M14x2	16	16+18
SWM16	M16x2	16	20
SWM18x2	M18x2	20	25
SWM20x2x20	M20x2x20	20	32
SWM20x2x25	M20x2x25	25	40

upínací šroub pro upínače Weldon DIN 1835-B krátké provedení

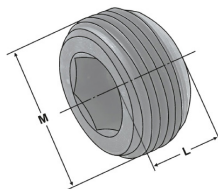

pro upínač	šroub	šroub	celkové množství
SK40.35.WE.16.ADB	SWM14		1
SK40.35.WE.20.ADB	SWKM16x2x13		1
SK40.35.WE.25.ADB	SWKM16x1x10	SWKM16x1x8	2
SK40.65.WE.32.ADB	SWKM16x1x10		2
BT40.35.WE.16.ADB	SWM14		1
BT40.35.WE.20.ADB	SWKM16x2x13		1
BT40.35.WE.25.ADB	SWKM16x1x10	SWKM16x1x8	2
BT40.65.WE.32.ADB	SWKM16x1x8	SWKM16x1x12	2

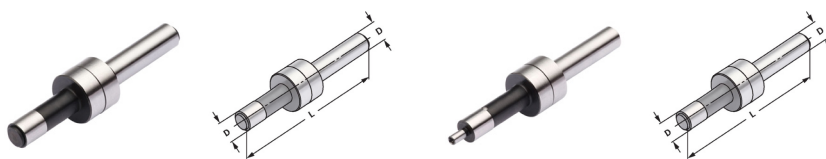

Mechanická najížděcí sonda

Název	D	L	d
V10.84.MS.10.2D	10	84	-
V10.94.MS.4.2D	10	94	4

použití: otáčky nástroje cca. 600 ot/min
přesnost nastavení 0,01 mm
všechny části jsou kalené a broušené

rozměr 10: se souběžným hrotem 10 mm
rozměr 10/4: s osazeným hrotem 10/4 mm

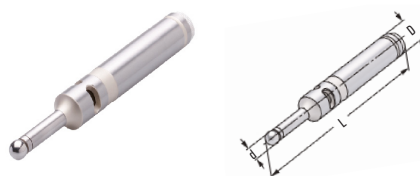

Optická najížděcí sonda 2D

Název	D	L	d
V16.100.OS.10.2D	16	100	10
V20.160.OS.10.2D	20	160	10

přesnost nastavení 0,01 mm
baterie CR2032 3,0V

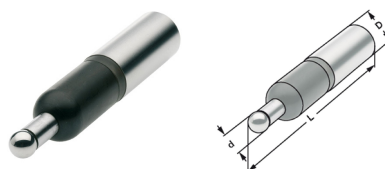

Optická najížděcí sonda 3D

Název	D	L	d
V16.110.OS.10.3D	16	110	10
V20.106.OS.10.3D	20	106	10

přesnost nastavení 0,01 mm
baterie: 1,5V / LR1 / N

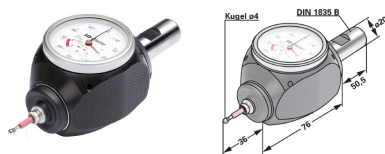

Mechanický 3D snímač

Název	D	L	d
V20.162,5.MS.4.3D	20	162,5	4

pro najíždění nulových bodů obrobků a dalšího měření
ochrana IP67

Tažné čepy DIN 69872 A+B



provedení A

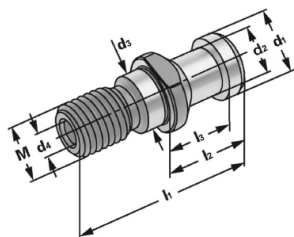

provedení B

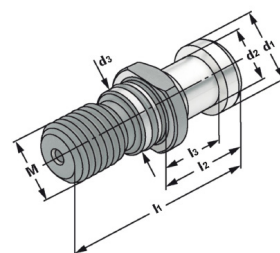

provedení A - vrtaný bez „O“ kroužku

Název	M	l ₁	l ₂	l ₃	d ₁	d ₂	d ₃	d ₄
69872.M12.K	M12	44	24	19	13	9	13	3,0
69872.M16.K	M16	54	26	20	19	14	17	7,0
69872.M24.K	M24	74	34	25	28	21	25	11,5

provedení A - vrtaný s „O“ kroužkem

69872.M16.KO	M16	54	26	20	19	14	17	7,0
69872.M24.KO	M24	74	34	25	28	21	25	11,5

provedení B - nevrtaný s „O“ kroužkem

69872.M16.0	M16	54	26	20	19	14	17	-
69872.M24.0	M24	74	34	25	28	21	25	-

DIN 69872 A | prodloužený + 3 mm



provedení A



provedení A - vrtaný s „O“ kroužkem

Název	M	l ₁	l ₂	l ₃	d ₁	d ₂	d ₃	d ₄
69872.M16.KO.3	M16	54	26	20	19	14	17	7,0



Tažné čepy ISO 7388

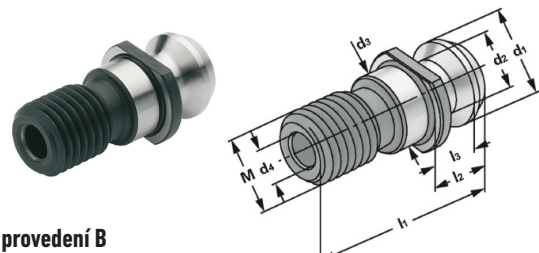

provedení B

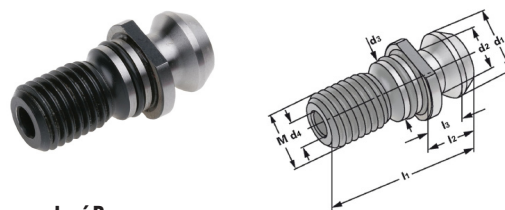

provedení B

provedení B - vrtaný bez „0“ kroužku

Název	M	l ₁	l ₂	l ₃	d ₁	d ₂	d ₃	d ₄
7388.M16.K	M16	44,5	16,40	11,15	18,95	12,95	17	7,0
7388.M24.K	M24	65,5	25,55	17,95	29,10	19,60	25	11,5

provedení B - vrtaný s „0“ kroužkem

7388.M16.KO	M16	44,5	16,40	11,15	18,95	12,95	17	7,0
7388.M24.KO	M24	65,5	25,55	17,95	29,10	19,60	25	11,5

provedení 7388 - nevrtaný s „0“ kroužkem

7388.M16.0	M16	44,5	16,40	11,15	18,95	12,95	17	-
7388.M24.0	M24	65,5	25,55	17,95	29,10	19,60	25	-

provedení 7388 - nevrtaný bez „0“ kroužku

7388.M24	M24	65,5	25,55	17,95	29,10	19,60	25	-
----------	-----	------	-------	-------	-------	-------	----	---

ISO 7388 | prodloužený + 3 mm



vrtaný s „0“ kroužkem

Název	M	l ₁	l ₂	l ₃	d ₁	d ₂	d ₃	d ₄
7388.M16.KO.3	M16	47,5	19,25	14,15	18,95	12,95	17	7,3

Tažné čepy JIS B 6339 (MAS 403 BT)

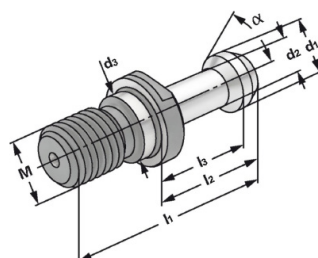

nevrtaný bez „O“ kroužku

Název	M	α	l_1	l_2	l_3	d_1	d_2	d_3
6339.M12.45	M12	45°	43	23	18	11	7	12,5
6339.M12.60	M12	60°	43	23	18	11	7	12,5
6339.M16.45	M16	45°	60	35	28	15	10	17,0
6339.M16.60	M16	60°	60	35	28	15	10	17,0
6339.M16.90	M16	90°	60	35	28	15	10	17,0
6339.M24.45	M24	45°	85	45	35	23	17	25,0
6339.M24.60	M24	60°	85	45	35	23	17	25,0
6339.M24.90	M24	90°	85	45	35	23	17	25,0

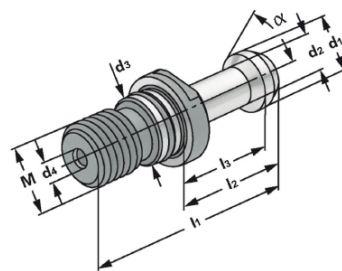

vrtaný s „O“ kroužkem

Název	M	α	l_1	l_2	l_3	d_1	d_2	d_3	d_4
6339.M12.45.KO	M12	45°	43	23	18	11	7	12,5	2,5
6339.M12.60.KO	M12	60°	43	23	18	11	7	12,5	2,5
6339.M16.45.KO	M16	45°	60	35	28	15	10	17	4,0
6339.M16.60.KO	M16	60°	60	35	28	15	10	17	4,0
6339.M16.90.KO	M16	90°	60	35	28	15	10	17	4,0
6339.M24.45.KO	M24	45°	85	45	35	23	17	25	6,0
6339.M24.60.KO	M24	60°	85	45	35	23	17	25	6,0
6339.M24.90.KO	M24	90°	85	45	35	23	17	25	6,0



Tažné čepy

JIS B 6399 (MAS 403 BT) prodloužené + 3 mm

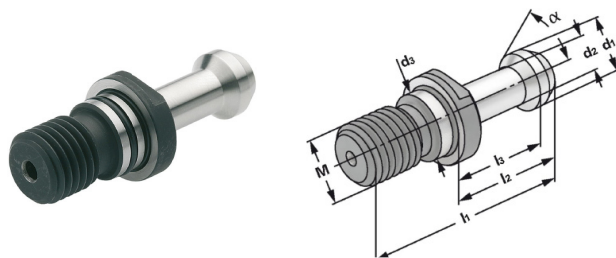

vrtaný s „O“ kroužkem

Název	M	α	l ₁	l ₂	l ₃	d ₁	d ₂	d ₃	d ₄
6399.M16.45.KO.3	M16	45°	57	32	25	15	10	17	4,0
6399.M16.60.KO.3	M16	60°	57	32	25	15	10	17	4,0
6399.M16.90.KO.3	M16	90°	57	32	25	15	10	17	4,0

nevrtaný s „O“ kroužkem

Název	M	α	l ₁	l ₂	l ₃	d ₁	d ₂	d ₃
6399.M16.45.O.3	M16	45°	57	32	25	15	10	17
6399.M16.60.O.3	M16	60°	57	32	25	15	10	17
6399.M16.90.O.3	M16	90°	57	32	25	15	10	17

DIN 2080 s drážkou Ott

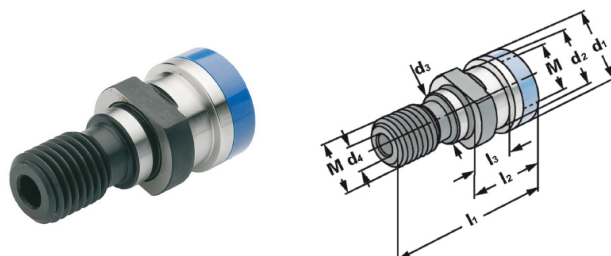

vrtaný s vnitřním závitem

Název	M	l ₁	l ₂	l ₃	d ₁	d ₂	d ₃	d ₄
2080.M16.K	M16	53,0	25,1	13,6	25,00	21,1	17	7,0
2080.M24.K	M24	65,1	25,1	13,3	39,60	32,0	25	7,0

Rychlovýměnný upínač závitníku



bez bezpečnostní spojky

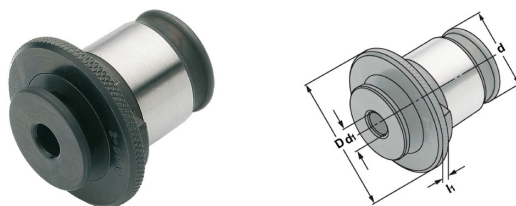

Název	D	d	l_1	Stopka d	Čtyřhran
UZB1 2.8x2.1	30	19	4	2,8	2,1
UZB1 3.5x2.7	30	19	4	3,5	2,7
UZB1 4x3	30	19	4	4	3
UZB1 4.5x3.4	30	19	4	4,5	3,4
UZB1 6x4.9	30	19	4	6	4,9
UZB1 7x5.5	30	19	4	7	5,5
UZB1 8x6.2	30	19	4	8	6,2
UZB1 9x7	30	19	4	9	7
UZB1 10x8	30	19	4	10	8
UZB1 11x9	30	19	4	11	9
UZB2 6x4.9	48	31	5	6	4,9
UZB2 7x5.5	48	31	5	7	5,5
UZB2 8x6.2	48	31	5	8	6,2
UZB2 9x7	48	31	5	9	7
UZB2 10x8	48	31	5	10	8
UZB2 11x9	48	31	5	11	9
UZB2 12x9	48	31	5	12	9
UZB2 14x11	48	31	5	14	11
UZB2 16x12	48	31	5	16	12
UZB2 18x14.5	48	31	5	18	14,5
UZB3 11x9	70	48	6	11	9
UZB3 12x9	70	48	6	12	9
UZB3 14x11	70	48	6	14	11
UZB3 16x12	70	48	6	16	12
UZB3 18x14.5	70	48	6	18	14,5
UZB3 20x16	70	48	6	20	16
UZB3 22x18	70	48	6	22	18
UZB3 25x20	70	48	6	25	20
UZB3 28x22	70	48	6	28	22



Rychlovýměnný upínač závitníku

s bezpečnostní spojkou

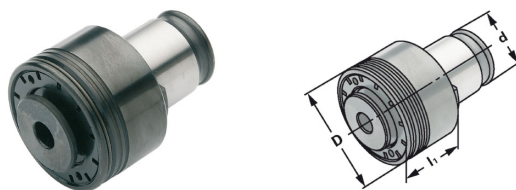

Název	D	d	l_1	Stopka d	Čtyřhran	M	DIN
UZS1 2.8x2.1 M2	32	19	25	2,8	2,1	M2	371
UZS1 2.8x2.1 M2.5	32	19	25	2,8	2,1	M2,5	371
UZS1 3.5x2.7	32	19	25	3,5	2,7	M3	371
UZS1 4x3	32	19	25	4	3	M3,5	371
UZS1 4.5x3.4	32	19	25	4,5	3,4	M4	371
UZS1 6x4.9 M5	32	19	25	6	4,9	M5	371
UZS1 6x4.9 M6	32	19	25	6	4,9	M6	371
UZS1 8x6.2	32	19	25	8	6,2	M8	371
UZS1 7x5.5	32	19	25	7	5,5	M7	376
UZS1 10x8	32	19	25	10	8	M10	371
UZS1 9x7	32	19	25	9	7	M12	376
UZS1 11x9	32	19	25	11	9	M14	376
UZS2 6x4.9 M5	50	31	31	6	4,9	M5	371
UZS2 6x4.9 M6	50	31	31	6	4,9	M6	371
UZS2 8x6.2	50	31	31	8	6,2	M8	371
UZS2 7x5.5	50	31	31	7	5,5	M10	376
UZS2 10x8	50	31	31	10	8	M10	371
UZS2 9x7	50	31	31	9	7	M12	376
UZS2 11x9	50	31	31	11	9	M14	376
UZS2 12x9	50	31	31	12	9	M16	376
UZS2 14x11	50	31	31	14	11	M18	376
UZS2 16x12	50	31	31	16	12	M20	376
UZS2 18x14.5	50	31	31	18	14,5	M22	376
UZS3 11x9	72	48	41	11	9	M14	376
UZS3 12x9	72	48	41	12	9	M16	376
UZS3 14x11	72	48	41	14	11	M18	376
UZS3 16x12	72	48	41	16	12	M20	376
UZS3 18x14.5 M22	72	48	41	18	14,5	M22	376
UZS3 18x14.5 M24	72	48	41	18	14,5	M24	376
UZS3 20x16	72	48	41	20	16	M27	376
UZS3 22x18	72	48	41	22	18	M30	376
UZS3 25x20	72	48	41	25	20	M33	376
UZS3 28x22	72	48	41	28	22	M36	376



Kleštinový upínač pro kleštiny ER

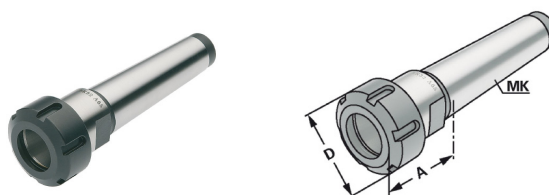

Název	MK	Rozsah	A	D	
MK2.45.ER16*	MK2	1 – 10 (ER 16)	45	32	ER16K
MK2.50.ER25	MK2	2 – 16 (ER 25)	50	42	ER25K
MK2.70.ER32	MK2	2 – 20 (ER 32)	70	50	ER32K
MK3.56.ER25	MK3	2 – 16 (ER 25)	56	42	ER25K
MK3.70.ER32	MK3	2 – 20 (ER 32)	70	50	ER32K
MK4.63.ER25	MK4	2 – 16 (ER 25)	63	42	ER25K
MK4.65.ER32	MK4	2 – 20 (ER 32)	65	50	ER32K
MK5.86.ER40	MK5	3 – 26 (ER 40)	86	63	ER40K

dodávka: s vyváženou upínací maticí, bez montážního klíče

* s šetihannou upínací maticí

Redukční pouzdra

redukční pouzdra pro nástroje s Morse stopkou DIN 2185

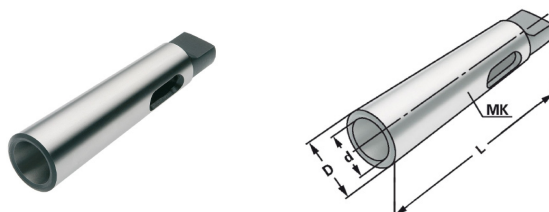



Název	D	d	L
MK2.MK1.92	MK2	MK1	92
MK3.MK2.98	MK3	MK2	112
MK4.MK2.124	MK4	MK2	124
MK4.MK3.132	MK4	MK3	140
MK5.MK3.156	MK5	MK3	156
MK5.MK4.171	MK5	MK4	171
MK6.MK4.218	MK6	MK4	218
MK6.MK5.218	MK6	MK5	218

kalené, vnitřní / vnější povrch broušený

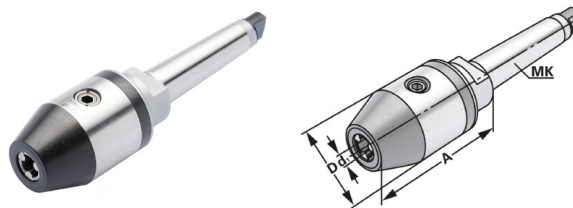

Vrtací hlavička



Název	MK	Rozsah	A	D	
MK3.V.113	MK3	1,0 - 13	98	50	VT6
MK3.V.216	MK3	2,5 - 16	103	50	VT6
MK4.V.113	MK4	1,0 - 13	100	50	VT6
MK4.V.216	MK4	2,5 - 16	105	50	VT6

použití: pravé / levé otáčky

dodávka: bez montážního klíče

Vrtací hlavička pro redukci

DIN 238

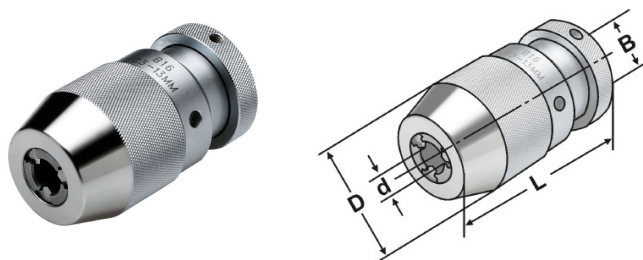

Název	B	Rozsah	D	L
B12.V.38	B12	0,3 - 8	37	80
B16.V.513	B16	0,5 - 13	50	95.5
B16.V.316	B16	3,0 - 16	50	103.5

pro upínání hladké stopky

samosvorná, bez montážního klíče



Upínač pro tepelné upínání - prodloužení



pro válcové upínací stopky

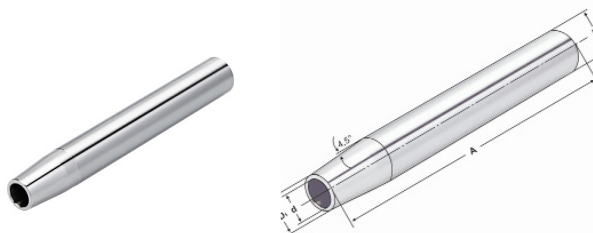

Název	d	D	D ₁	l ₁	l ₂	A
V20.150.T4.03.AD	3	20	10	-	-	150
V20.150.T4.04.AD	4	20	10	-	-	150
V20.150.T4.05.AD	5	20	10	-	-	150
V20.150.T4.06.AD*	6	20	10	36	10	150
V20.150.T4.08.AD*	8	20	12	36	10	150
V20.150.T4.10.AD*	10	20	14	41	10	150
V20.150.T4.12.AD*	12	20	16	46	10	150

pro průměry stopek 3, 4 a 5 mm pouze pro karbidové nástroje

pro průměry stopek 3, 4 a 5 mm s tolerancí h4 a průměry stopek 6 až 32 s tolerancí h6

vhodné pro přístroje, které používají ohřev indukční, kontaktní a teplým vzduchem

* s dorazovým šroubem

l₁ = maximální upínací délka **l₂** = maximální délkové nastavení

Upínač pro vrtačkovou hlavičku

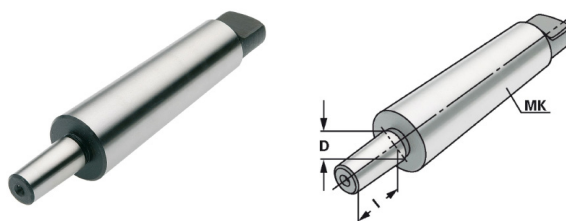

Název	MK	D	l
MK2.B12	MK2	B12	12,06
MK3.B12	MK3	B12	12,06
MK4.B12	MK4	B12	12,06
MK2.B16	MK2	B16	29
MK3.B16	MK3	B16	29
MK4.B16	MK4	B16	29

kalené, broušené



Prodloužení pro kleštiny ER

DIN 6499 (ISO 15488)

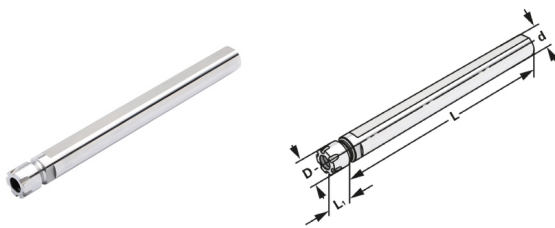

s upínací drážkou

Název	d_{H6}	Rozsah	D	L	L ₁	
VD16.150.ERM.11.AD	16	1 - 7 (ER11)	16	150	20	ER11MK
VD20.150.ERM.16.AD	20	1 - 10 (ER16)	22	150	30	ER16MK

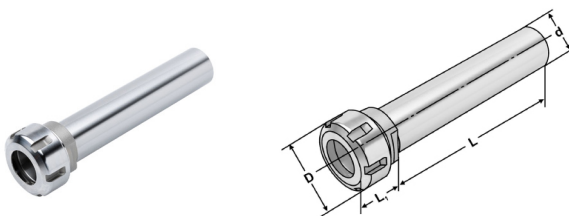

s hladkou stopkou

Název	d_{H6}	Rozsah	D	L	L ₁	
V16.150.ER.16.AD	16	1 - 10 (ER16)	32	143	30	ER16K
V20.150.ER.25.AD	20	1 - 16 (ER25)	42	140	40	ER25K
V32.150.ER.32.AD	32	2 - 20 (ER32)	50	150	35	ER32K

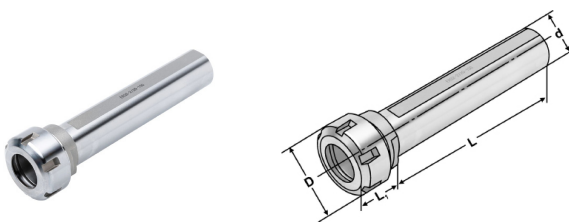

s upínací drážkou

Název	d_{H6}	Rozsah	D	L	L ₁	
VD16.150.ER.16.AD	16	1 - 10 (ER16)	32	150	30	ER16K
VD20.150.ER.25.AD	20	1 - 16 (ER25)	42	150	40	ER25K
VD32.150.ER.32.AD	32	2 - 20 (ER32)	50	150	35	ER32K
VD40.120.ER.32.AD	40	2 - 20 (ER32)	50	120	35	ER32K

dodávka: s upínací maticí, bez montážního klíče

Vytěrák vřetene

pro čištění vnitřních kuželů vřeten, redukcí a nástrojových upínačů

Název	Kužel
VER16	ER16
VER25	ER25
VER32	ER32
VER40	ER40
VMK1	MK1
VMK2	MK2
VMK3	MK3
VMK4	MK4
VMK5	MK5
VK30	SK/ISO/BT/CAT30
VK40	SK/ISO/BT/CAT40
VK50	SK/ISO/BT/CAT50
VH32	HSK32 Form A-C-E
VH40	HSK40 Form A-C-E
VH50	HSK50 Form A-C-E
VH63	HSK63 Form A-C-E
VH80	HSK80 Form A-C-E
VH100	HSK100 Form A-C-E
VH63F	HSK63 Form F

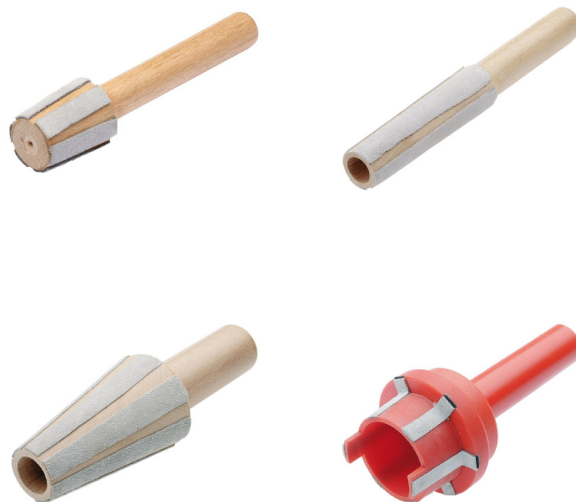

služby

ETGS



služby

Tool-management

Proč využít naše TM boxy

- 1 DOSTUPNOST NÁSTROJŮ**

Nástroje k dispozici 24 hodin 7 dní v týdnu.
- 2 BEZPEČNÉ SKLADOVÁNÍ**

Nástroje uloženy bezpečně v oddělených přihrádkách.
- 3 100% OCHRANA NÁSTROJŮ**

Nástroje nelze odebrat bez předchozí identifikace uživatele.
- 4 ELIMINACE NEOFICIÁLNÍCH SKLADŮ**

Není potřeba vytvářet zásoby nástrojů u stroje, na dílně. Nástroje jsou vždy připraveny v TM Boxu.
- 5 REDUKCE VÁZANÉHO KAPITÁLU**

Finanční prostředky nejsou vázané v nadbytečných nástrojích, naopak jsou volné na další investice.
- 6 SERVISNÍ A PROVOZNÍ TÝM TGS**

Proškolený a zkušený personál zajišťuje doprovodné služby – správa hardwaru i softwaru, doplňování apod.
- 7 BALÍČKY SLUŽEB**

Několik variant nastavení služby dle konkrétních potřeb.
- 8 DISTRIBUČNÍ MEZISKLAD**

Možnost zřídit mezisklad mimo TM Box v prostorách TGS (nutné smluvní vymezení).
- 9 SEZNAM NÁSTROJŮ PRO VÝROBU**

Přehled nástrojů pro technickou přípravu výroby. Při přípravě výroby lze využít sortiment nástrojů, které jsou v TM Boxu, či včas zajistit dostupnost nástrojů nových.
- 10 SLEDOVATELNOST NÁKLADŮ**

Pohyby a odběry nástrojů jsou evidovány. Je možné sledovat náklady na jednotlivé pracovníky, zakázky nebo stroje.
- 11 ON-LINE PODPORA REPORTY**

Výstupní data stále k dispozici – aktuální přesné informace o hodnotě skladu, investic do nástrojů apod. Automatické reportování emailem. Možná podpora TGS pomocí vzdáleného přístupu.
- 12 SPRÁVA OSTŘENÝCH NÁSTROJŮ**

Software umožňuje správu ostřených nástrojů, např. přednostní odběr ostřeného nástroje.
- 13 NÁSTROJE MĚŘIDLA OCHRANNÉ POMŮCKY**

Mimo nástroje je možné skladovat také jiné obrátkové položky spojené s výrobou, např. měřidla či ochranné pomůcky.



Servisní služby TGS

Servisní služby pro nás nejsou jen otázkou rychlé dostupnosti havarijního servisu, ale i otázkou preventivní údržby. Ponechte agendu vedení servisního deníku a provádění garančních kontrol na našem servisním týmu a dispečinku.



1 Servisní tým

- servisní dispečink
- tým zkušených techniků po celé ČR
- tým metrologů a programátor

2 Autorizovaný servis

- certifikace výrobcem
- odborná školení u výrobců
- převímky strojů u výrobce

3 Moderní vybavení

- digitální váhy
- laser
- ball-bary
- granitová měřidla
- měřák upínací síly

4 Sklad náhradních dílů

- vybraná vřetena skladem
- více než 1000 položek skladem

5 Opravy vřeten

- opravy vřeten a hlav přímo v TGS
- vyvážení vřeten
- zaběhnutí včetně teplotní diagnostiky

6 Velké generální opravy

- komplexní opravy strojů
- výměny vedení
- broušení a zaškrabávání vodících ploch

7 Vzdálená diagnostika

- připojení a kontrola stroje na dálku
- kontrola zatížení a opotřebení

8 PLC & Systém

- úpravy funkcí dle požadavků
- ladění pohonů
- příprava m-funkcí a soft-key kláves



Měření přesnosti obráběcích strojů a rovnání

Provádíme měření strojů podle metod popsaných v ISO 230-1. Na základě měření vyhotovíme protokol podle typu a velikosti Vašeho stroje a provedeme seřízení geometrie nebo softwarovou kompenzaci stroje. Pomůžeme zvýšit kvalitu výroby, snížit zmetkovitost vlivem nepřesnosti stroje, odhalíme závadu před tím, než se stroj zastaví.

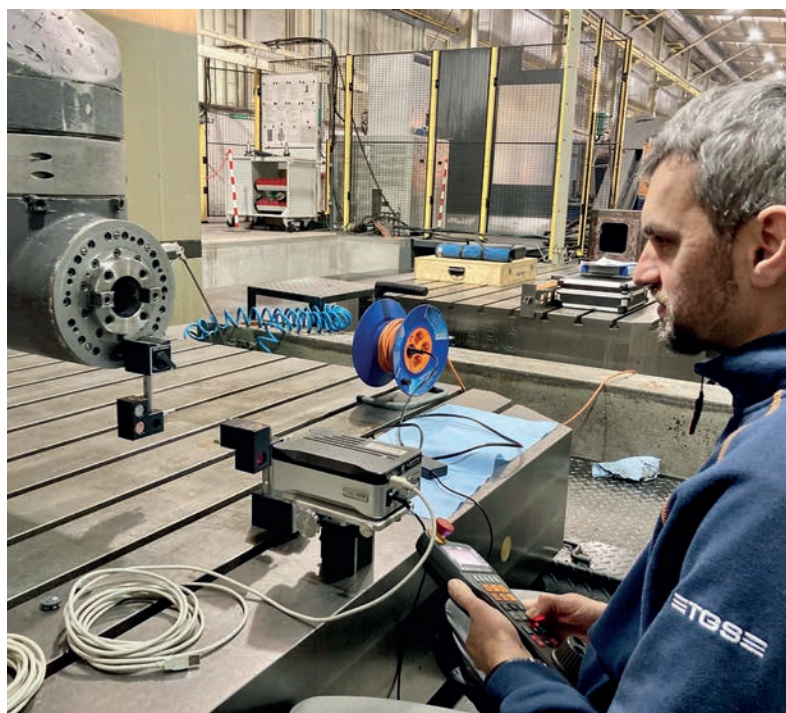

1

Přesnost a opakované nastavení polohy lineárních os laserovým interferometrem Renishaw XL-80.

2

Měření kruhové interpolace systémem Renishaw ballbar v souladu s mezinárodními normami ISO, ANSI/ASME apod.

3

Přesnost a opakované nastavení polohy rotačních os kalibrátorem os Renishaw XR20-W v rozsahu 0-360°.

4

Měření upínací síly ve vřetení přístrojem OTT Power Check jako prevence poškození vřetene.

5

Měření přímosti laserovým interferometrem až do vzdálenosti 30 m v horizontální i vertikálním směru.

6

Při vystavení protokolu dáme doporučení dalšího postupu a nabídneme možnost rovnání stroje.



Díleňská metrologie

Oddělení metrologie, které je nedílnou součástí prototypové výroby, garantuje výstupní kvalitu s využitím nutného vybavení a technicky správných postupů. Vždy se snažíme diskusí nad výstupní přesností začít a odrazit požadavky v samotném výrobním procesu.

3D měřící centrum ZEISS ACURA II

Vysoce přesný výkonný měřící stroj, tuhý a přesto lehký portál stroje disponuje dynamikou a tepelnou stabilitou. Díky CNC řízení je vhodný i pro opakované měření či série.

Rozsah měření X, Y, Z: 1200x2400x1000 mm
Chyba měření: 1,2 + L/350 μm
Certifikace: ISO 10360

Měřící rameno ROMER ABSOLUTE ARM

Mobilní 3D měření sondou a laserové skenování v jednom. Kloubová konstrukce nemá konkurenci z hlediska snadnosti pohybu a snadnosti měření, přitom při zachování vysoké přesnosti. Skenování využitelné pro reverse engineering či porovnání obrobku vůči CAM modelu.

Rozsah měření: 0-2500 mm
Chyba měření: ± 0,026 mm
Certifikace: ASME B 89.4.22, VDI/VDE 2617-9

Výškoměr MAHR DIGIMAR

Jednoduché, rychlé, přesto přesné měření bez nutnosti použití softwaru či počítače.

Rozsah měření: 0-1000 mm
Chyba měření: 1,8+L/600 μm
Certifikace: ASME B 89.4.22



Upínací přípravky

mechanické / automatické / vakuové

Konstruujeme, vyrábíme a odladíme upínací přípravky s mechanickým, hydraulickým či vakuovým vyvozením upínací síly, které umožní zkrátit nevýrobní čas a zvýšit produktivitu, pomohou upnout tvarově složité obrobky či usnadní upínání při větších výrobních sériích v kombinaci např. s robotizací nebo jinou automatizací.

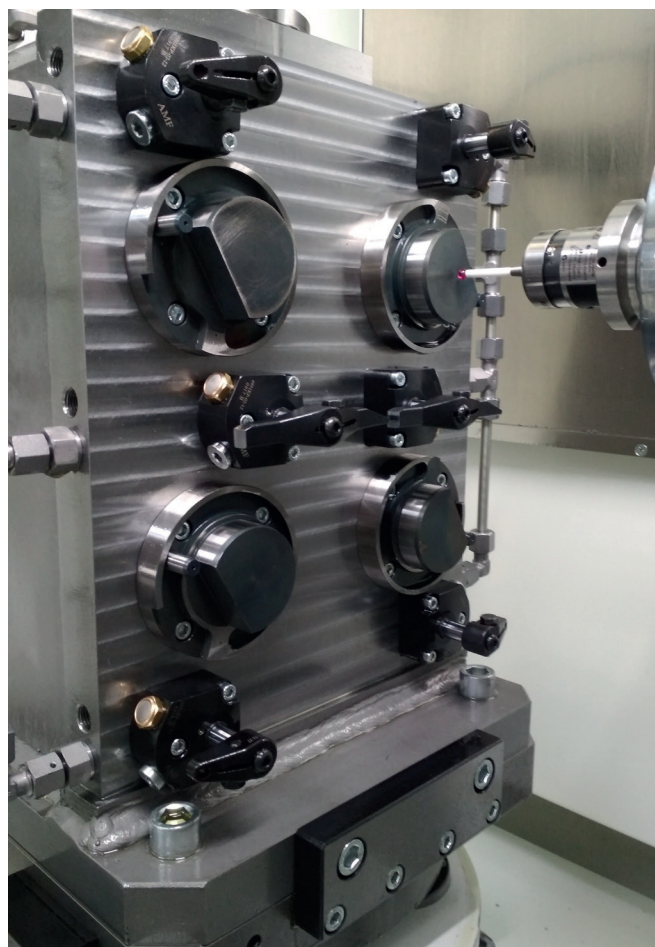

Mechanické upínací přípravky

- Snížení zmetkovitosti vlivem špatného upnutí
- Možnost modulární konstrukce
- Bez nutnosti přívodu dalších médií do pracovního prostoru
- Upnutí více dílců na jednom přípravku
- Upínání dílců mimo pracovní prostor
- Zvýšení stability řezu
- Integrace nulových bodů

Automatické upínací přípravky

- Upínání bez použití nářadí
- Vysoká rychlost upnutí oproti mechanickému způsobu
- Automatické vystředění dílců
- Upnutí více dílců najednou
- Možnost řízení upínací síly
- Hydraulický agregát součástí zařízení
- Integrace nulových bodů

Vakuové upínací přípravky

- Možnost průběžného řízení upínací síly
- Vhodné pro nemagnetické materiály
- Cesta upnutí skořepinových dílů
- Doporučení pro dílce z hliníkových slitin, plastů a kompozitů



Úpravy strojů a průmyslová automatizace

Navrhujeme a provádíme úpravy strojů od mechanických modifikací, přes automatizační prvky až po uzpůsobení software řízení stroje vedoucí ke zvýšení produktivity a efektivity Vaší výroby.

Úpravy obráběcích strojů

- Úprava PLC stroje
- Doplnění krytování stroje
- Bezpečnostní prvky
- Hydraulické rozvody
- Pneumatické rozvody

Průmyslová automatizace

- Jednoúčelové stroje
- Možnost vlastního PLC řízení
- Zrychlení výrobního procesu
- Robotizace pracoviště
- Bezobslužný provoz
- Provoz 24/7
- Dopravníkové systémy
- Regálové zakládání dílců

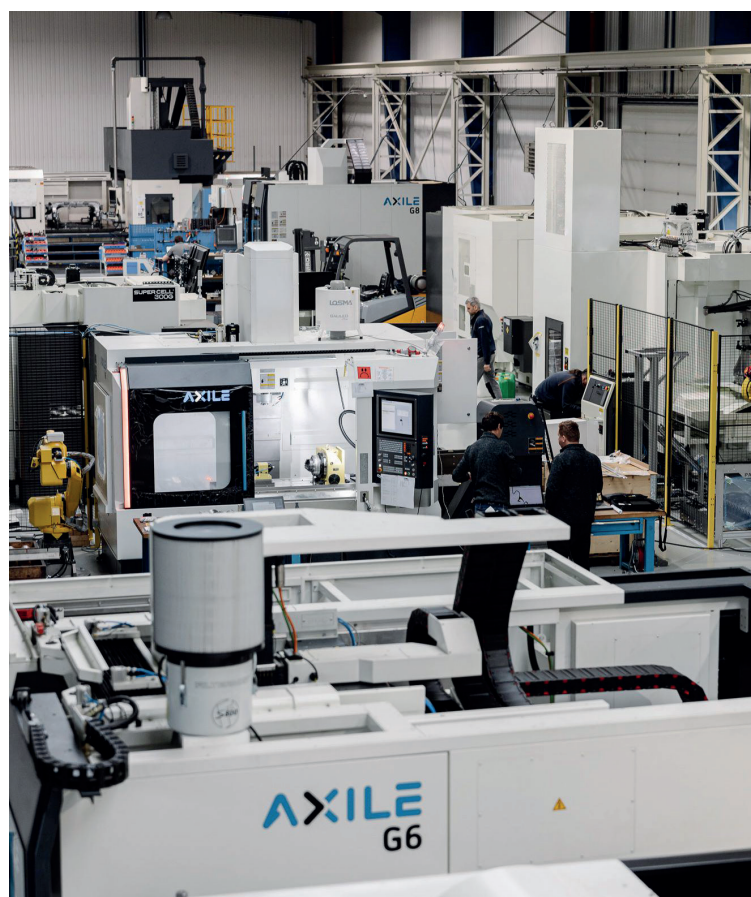

Prototypová výroba

zhmotnění myšlenky

Specializujeme se na realizaci prototypových projektů. Při dodávce nové technologie či optimalizaci té stávající vyrábíme ověřovací vzorky a testujeme výrobní časy jednotlivých komponent. Na zakázku navrhujeme a vyrábíme upínací prvky a následně provádíme zkoušky v reálném provozu.



Vlastní produkt & speciály

Zaměřujeme se na výrobu dílů vlastní konstrukce a produktů z portfolia TGS. Mimo standardních skladových položek vyrábíme speciální produkty připravené zákazníkovi na míru pro jeho konkrétní aplikaci jako např. upínací přípravek, paletizaci pro robota, nebo tvarový nástroj...

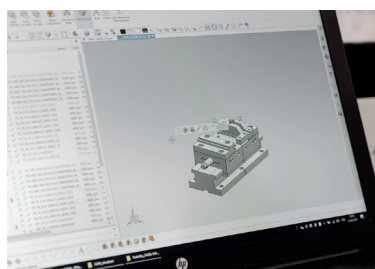

Prototypování dílů

Zajišťujeme prototypování dílů na moderních obráběcích centrech. Ověřujeme design a mechanické vlastnosti dílů v rámci přípravy pro sériovou výrobu a spolupracujeme na jejím zavádění a optimalizaci.

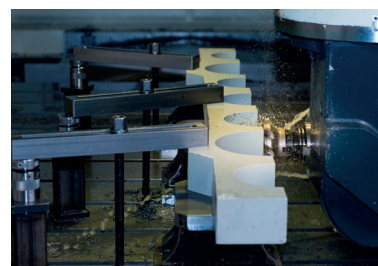

Kooperace

Nabízíme možnost kooperační výroby na rozmanitém strojovém parku, od přesných 5tiosých center po robustní portály. Kontrola dílů ve špičkově vybavené metrologii je standardem.





Sídlo

Plzeňská 610, 338 05 Mýto

 tgs@tgs.cz

Provozovna

Plzeňská 610, 338 05 Mýto

www.tgs.cz

ETGSE

